

Robot Dynamics

Hesheng Wang

Dept. of Automation

Shanghai Jiao Tong University

What is Robot Dynamics?

- Robot dynamics studies the relation between robot motion and forces and moments acting on the robot.

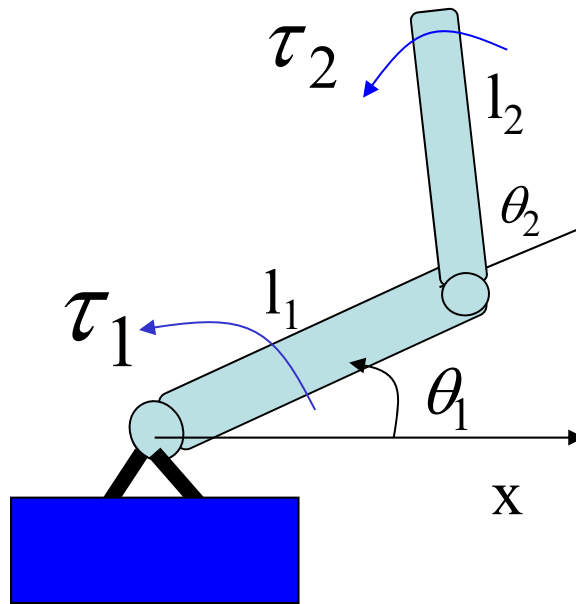

Rotation about a Fixed Axis

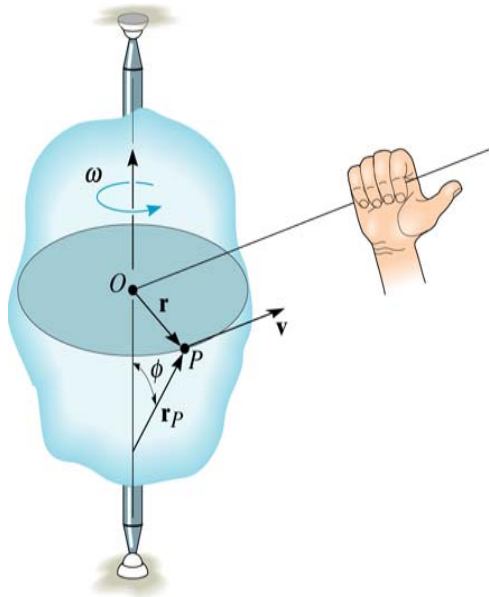

The velocity \mathbf{v} can be determined from the cross product of $\boldsymbol{\omega}$ and \mathbf{r}_p . Here \mathbf{r}_p is a vector from any point on the axis of rotation to P.

$$\mathbf{v} = \boldsymbol{\omega} \times \mathbf{r}_p = \boldsymbol{\omega} \times \mathbf{r}$$

The direction of \mathbf{v} is determined by the right-hand rule.

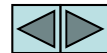

Rotation about a Fixed Axis

(continued)

The acceleration of P can also be defined by differentiating the velocity.

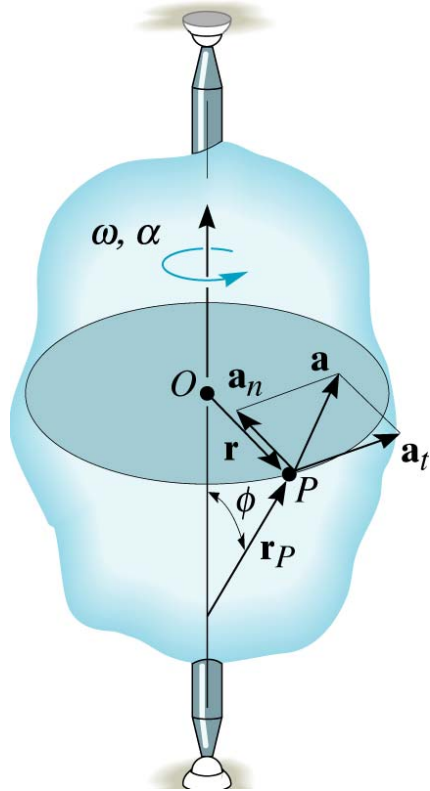

$$\mathbf{a} = d\mathbf{v}/dt = d\boldsymbol{\omega}/dt \times \mathbf{r}_P + \boldsymbol{\omega} \times d\mathbf{r}_P/dt$$
$$= \boldsymbol{\alpha} \times \mathbf{r}_P + \boldsymbol{\omega} \times (\boldsymbol{\omega} \times \mathbf{r}_P)$$

Tangent accel

Normal/centripetal acceleration

It can be shown that this equation reduces to

$$\mathbf{a} = \boldsymbol{\alpha} \times \mathbf{r} - \omega^2 \mathbf{r} = \mathbf{a}_t + \mathbf{a}_n$$

The magnitude of the acceleration vector is $a = \sqrt{(a_t)^2 + (a_n)^2}$

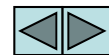

Rotation of a Vector

- Consider rotation of a vector about a axis.

Point P is rotating about axis \mathbf{u} .

\mathbf{r} is the position vector of point P.

$\dot{\theta}$: the speed of rotation

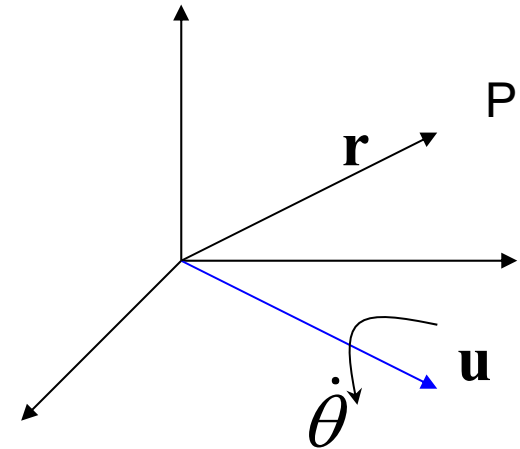

The angular velocity: $\boldsymbol{\omega} = \mathbf{u} \dot{\theta}$

The rate of change of position vector \mathbf{r} :

$$\frac{d}{dt} \mathbf{r} = \boldsymbol{\omega} \times \mathbf{r}$$

Rotation of a Frame

- Consider a frame B rotating about an unit vector \mathbf{u} .

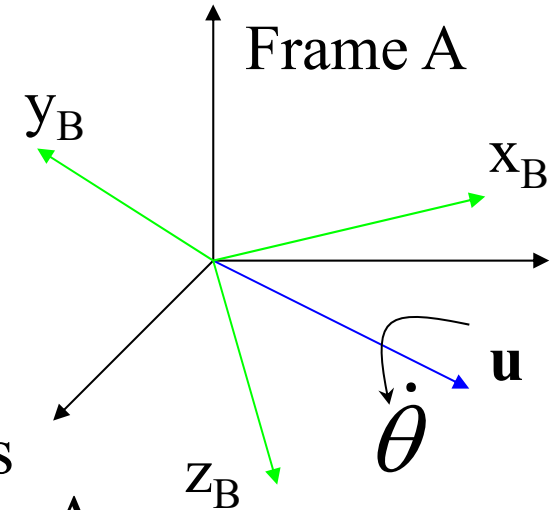

$\{\mathbf{i}_B, \mathbf{j}_B, \mathbf{k}_B\}$: unit directional vectors of the axes of frame B w.r.t. the reference frame A

$$\frac{d}{dt}\mathbf{i}_B = \boldsymbol{\omega} \times \mathbf{i}_B, \quad \frac{d}{dt}\mathbf{j}_B = \boldsymbol{\omega} \times \mathbf{j}_B, \quad \frac{d}{dt}\mathbf{k}_B = \boldsymbol{\omega} \times \mathbf{k}_B$$

The derivative of the rotation matrix of frame B :

$$\dot{\mathbf{R}} = \frac{d}{dt}(\mathbf{i}_B \quad \mathbf{j}_B \quad \mathbf{k}_B) = (\boldsymbol{\omega} \times \mathbf{i}_B \quad \boldsymbol{\omega} \times \mathbf{j}_B \quad \boldsymbol{\omega} \times \mathbf{k}_B)$$

$$\therefore \quad \boxed{\dot{\mathbf{R}} = \boldsymbol{\omega} \times \mathbf{R}}$$

General Motion

- A general motion can be considered a combination of a translation with a point and motion about the point.

$O - x_0 y_0 z_0$: A fixed reference frame

$A - x_1 y_1 z_1$: A frame that translate with A

The velocity relation:

$$\mathbf{V}_B = \mathbf{V}_A + \boldsymbol{\omega} \times \mathbf{r}$$

The acceleration relation:

$$\mathbf{a}_B = \mathbf{a}_A + \boldsymbol{\alpha} \times \mathbf{r} + \boldsymbol{\omega} \times (\boldsymbol{\omega} \times \mathbf{r})$$

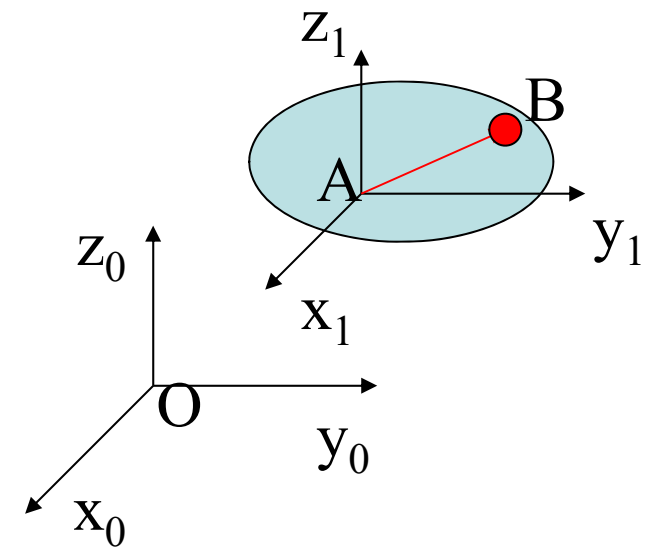

Introduction to Dynamics

Newton's Laws of Motion

First Law: A particle originally at rest, or moving in a straight line at constant velocity, will remain in this state if the resultant force acting on the particle is zero.

Second Law: If the resultant force on the particle is not zero, the particle experiences an acceleration in the same direction as the resultant force. This acceleration has a magnitude proportional to the resultant force.

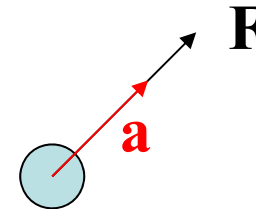

$$\mathbf{F} = m\mathbf{a}$$

m : the mass

\mathbf{F} : the net force

\mathbf{a} : the acceleration

Third Law: Mutual forces of action and reaction between two particles are equal, opposite, and collinear.

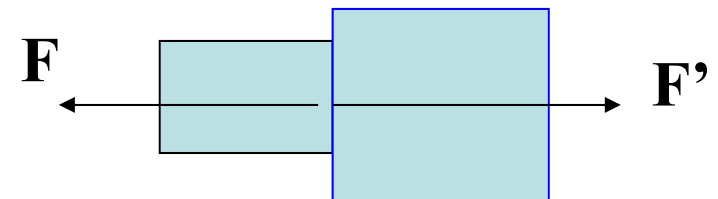

Example

Find the accelerations of the ball and the wedge.

Solution:

- (1) Draw the free-body diagram of the particles
- (2) Apply Newton's 2nd Law

For the ball

$$m_1 \ddot{x}_b = N \sin \theta \quad (1)$$

$$m_1 \ddot{y}_b = N \cos \theta - m_1 g \quad (2)$$

For the wedge

$$m_2 \ddot{x}_w = -N \sin \theta \quad (3)$$

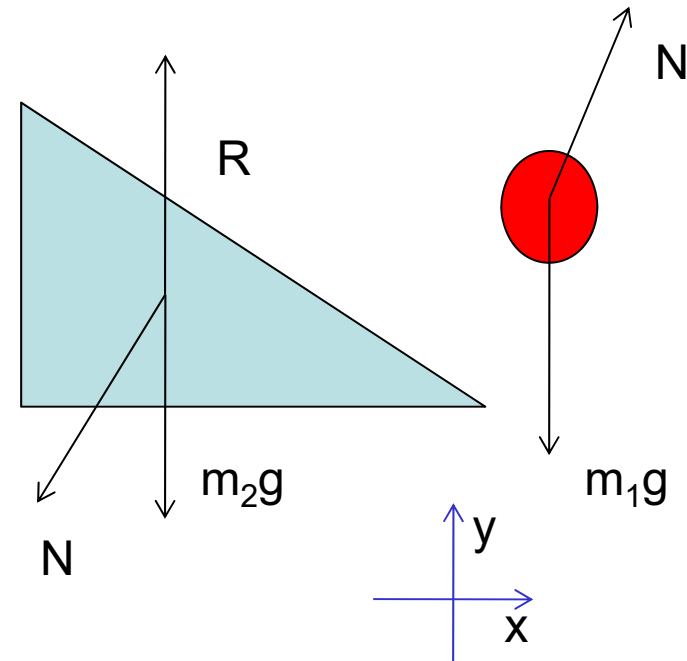
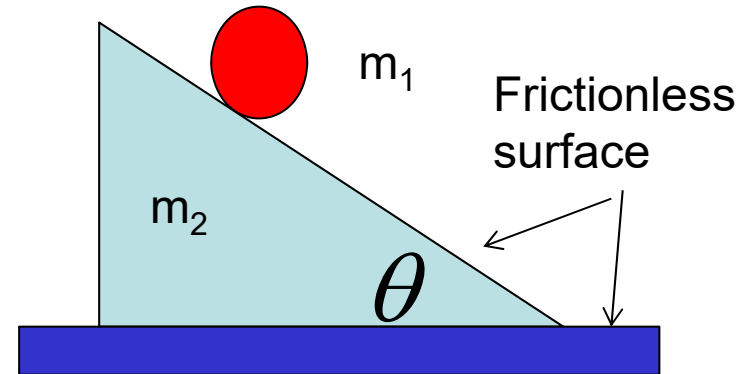

Example (continued)

- Consider acceleration relationship between the ball and the wedge

$$\mathbf{a}_b = \mathbf{a}_w + \mathbf{a}_{b/w}$$

$\mathbf{a}_{b/w}$: relative velocity of the ball
w.r.t. the wedge

Note that the relative velocity is along the surface of the wedge
From the diagram, we have

$$\ddot{x}_b = \ddot{x}_w + a_{b/w} \cos \theta \quad (4)$$

$$\ddot{y}_b = -a_{b/w} \sin \theta \quad (5)$$

From eqs. (1)-(5), we can solve the five unknowns, i.e. the acceleration

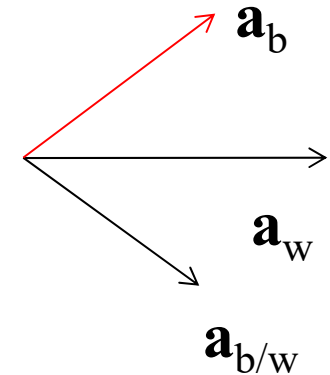

Linear Momentum

- Linear momentum: product of mass and velocity:

$$\mathbf{L} = m\mathbf{V}$$

- It is a vector, in the same direction as velocity
- SI Unit : $\text{Kg} \cdot \text{m/s}$

From Newton's 2nd Law :

$$\mathbf{F} = m\mathbf{a} = m \frac{d}{dt} \mathbf{V} = \dot{\mathbf{L}}$$

- **Principle of Linear Momentum:** The rate of change of the linear momentum of a particle is equal to the result force acting on the particle

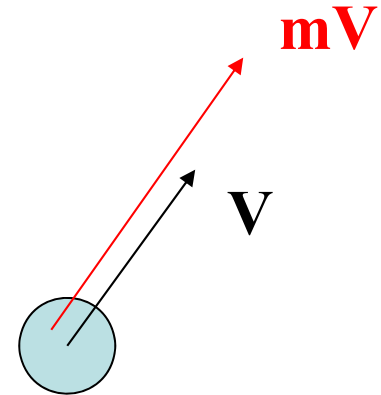

Angular Momentum

- \mathbf{r} : the position vector of a particle w.r.t. a reference point O .
- \mathbf{V} : the velocity of the particle
- m : the mass of the particle
- The angular momentum of the particle about reference O :

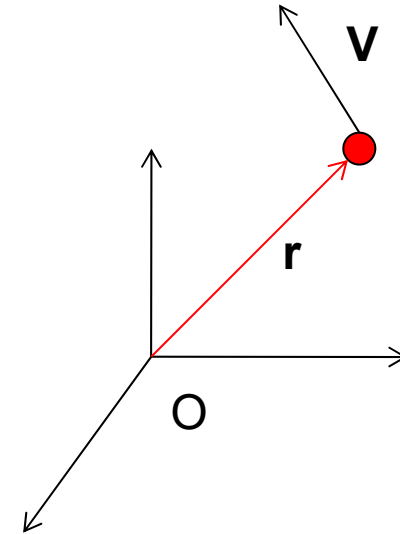

$$\mathbf{H}_o = \mathbf{r} \times m\mathbf{V}$$

\mathbf{H}_o is a vector perpendicular to both \mathbf{V} and \mathbf{r} .

Its direction is determined by the right-hand rule

Its unit is $\text{Kg} \cdot \text{m}^2 / \text{s}$

Principle of Angular Momentum

Consider a force F acting on the particle

Differentiating the angular momentum

$$\dot{\mathbf{H}}_o = \dot{\mathbf{r}} \times m\mathbf{V} + \mathbf{r} \times m\dot{\mathbf{V}} = \mathbf{r} \times \mathbf{F}$$

$$\Rightarrow \dot{\mathbf{H}}_o = \mathbf{r} \times \mathbf{F} = \mathbf{M}_o$$

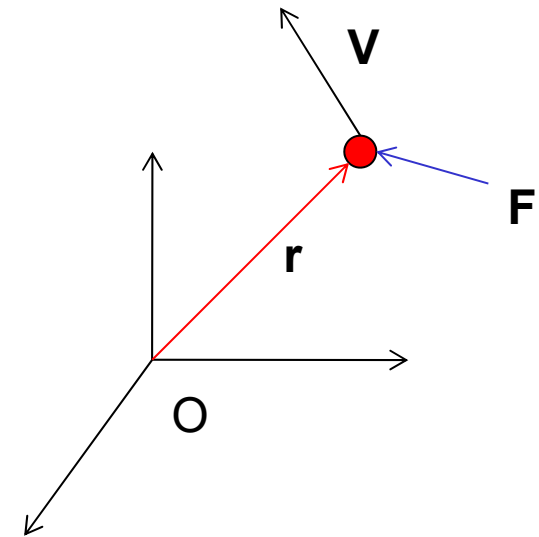

Principle of angular momentum: The rate of change of the angular momentum of particle about a **fixed point O** is equal to the resultant moment of forces acting on the particle about **point O**

Dynamics of a System of Particles

Consider a system of n particles.

f_i : the external force exerted on particle i

e_{ij} : the internal force exerted on particle i
by particle j

m_i : mass of particle i .

r_i : position vector of particle i

Linear momentum:
$$\mathbf{L} = \sum m_i \mathbf{V}_i = \sum m_i \frac{d}{dt} \mathbf{r}_i$$

\therefore The center of mass:
$$\mathbf{r}_c = \frac{\sum m_i \mathbf{r}_i}{\sum m_i} \Rightarrow \mathbf{L} = \sum m_i \dot{\mathbf{r}}_c = M \mathbf{V}_c$$

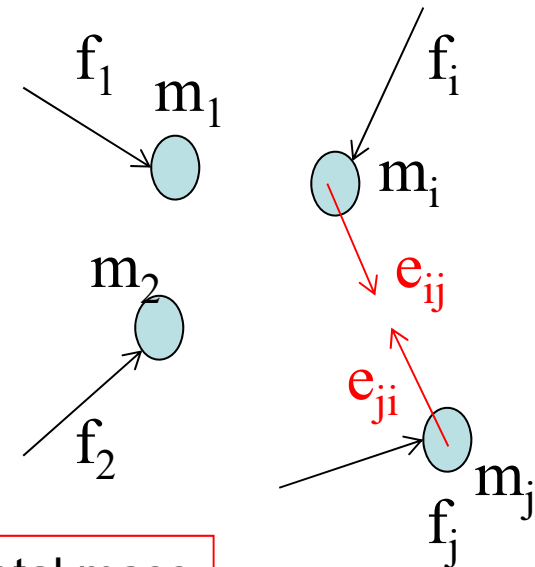

Total mass

Velocity of center of mass

The linear momentum of a system of particles is equal to the product of the total mass and the velocity of the center of mass

Dynamics of a System of Particles

Differentiating the linear momentum

$$\dot{\mathbf{L}} = \sum_i m_i \frac{d^2}{dt^2} \mathbf{r}_i = \sum_i (\mathbf{f}_i + \sum_j \mathbf{e}_{ij})$$

$$\because \sum_i \sum_j \mathbf{e}_{ij} = 0 \quad \Rightarrow \quad \dot{\mathbf{L}} = \sum_i \mathbf{f}_i$$

The rate of change the linear momentum of a system of particles is equal to the resultant of all **EXTERNAL** forces acting on the particles

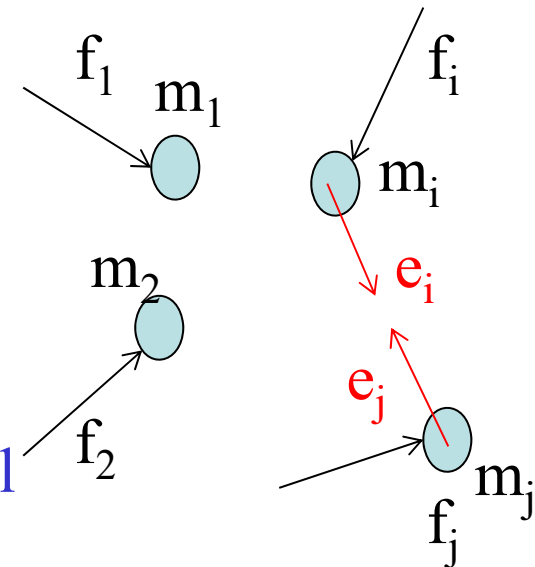

$$\because \mathbf{L} = M\mathbf{V}_C \quad \Rightarrow$$

$$M\mathbf{a}_c = \sum_i \mathbf{f}_i$$

\mathbf{a}_c : acceleration of center of mass

Equation of motion of Center of mass

The center of mass of the system moves as if all the forces and masses are concentrated at the center of mass

Angular Momentum of a System of Particles

Similarly, by differentiating the angular momentum

$$\dot{\mathbf{H}}_O = \sum_i \frac{d}{dt} \{ \mathbf{r}_i \times m \mathbf{V}_i \} = \mathbf{M}_O$$

The resultant moment of all **EXTERNAL** forces acting on the system about O

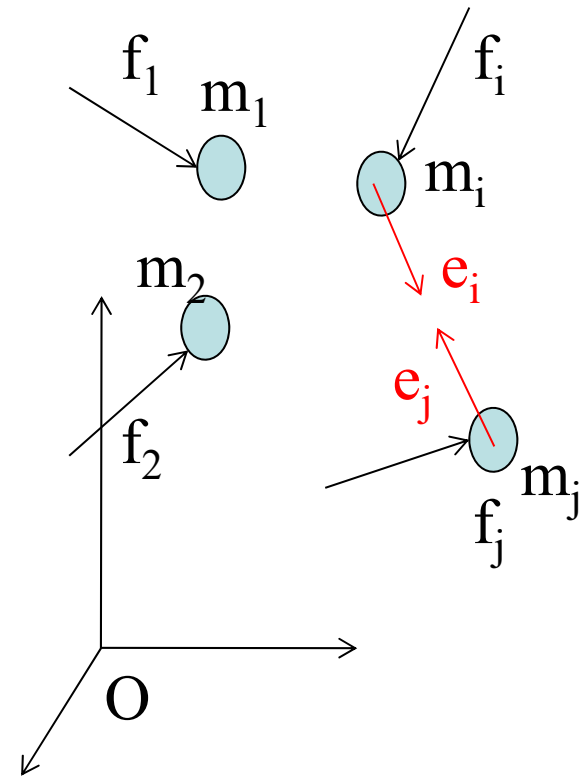

The reference point must be a **fixed** point. However, **the center of mass of the system** can be the reference point **even when it is moving**

Example:

Example: Calculate the angular acceleration of the massless link

Solution

Consider the two particles and the link as a system

- (1) Analyze the external forces
- (2) Consider the angular momentum about O

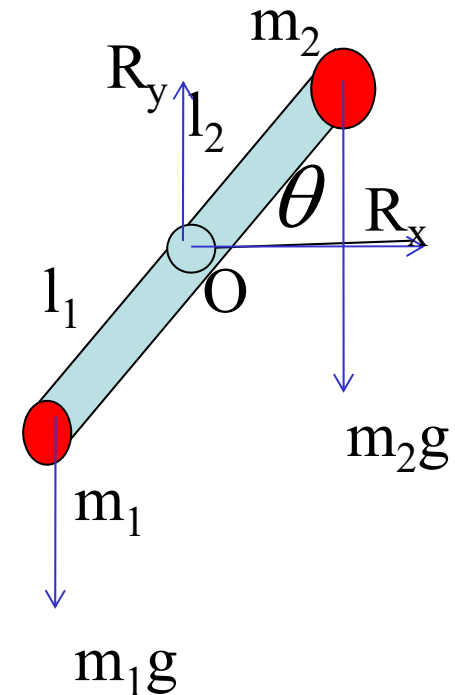

$$\dot{\mathbf{H}}_o = \mathbf{M}_o \Rightarrow \frac{d}{dt} \begin{pmatrix} 0 \\ 0 \\ (m_1 l_1^2 + m_2 l_2^2) \omega \end{pmatrix} = \begin{pmatrix} 0 \\ 0 \\ -m_2 g l_2 \cos \theta + m_1 g l_1 \cos \theta \end{pmatrix}$$

$$\dot{\omega} = \frac{(m_1 l_1 - m_2 l_2) \cos \theta}{m_1 l_1^2 + m_2 l_2^2}$$

Linear and Angular Momentums for Rigid Body

- Since a rigid body can be considered as a system with infinite number of particles, the linear momentum

$$\mathbf{L} = m\mathbf{V}_C$$

- The angular momentum about the center of mass

$$\mathbf{H}_C = \mathbf{I}\boldsymbol{\omega}$$

\mathbf{I} : Inertia tensor matrix about C.

$\boldsymbol{\omega}$: angular velocity of the body

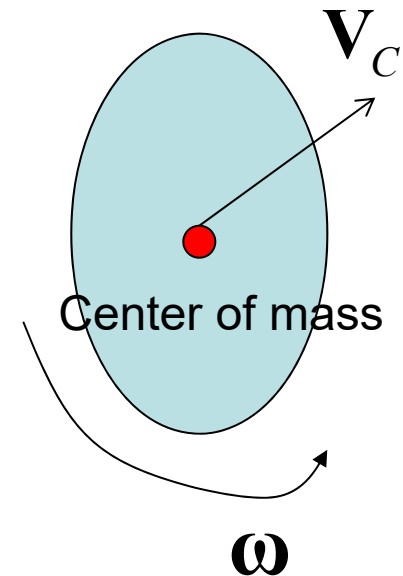

Newton's Equation and Euler's Equation

- A general motion can be considered a combination of a translation with the center of mass and motion about the center of mass

$O - x_0 y_0 z_0$: A fixed reference frame

$C - x_1 y_1 z_1$: A frame that translates with C

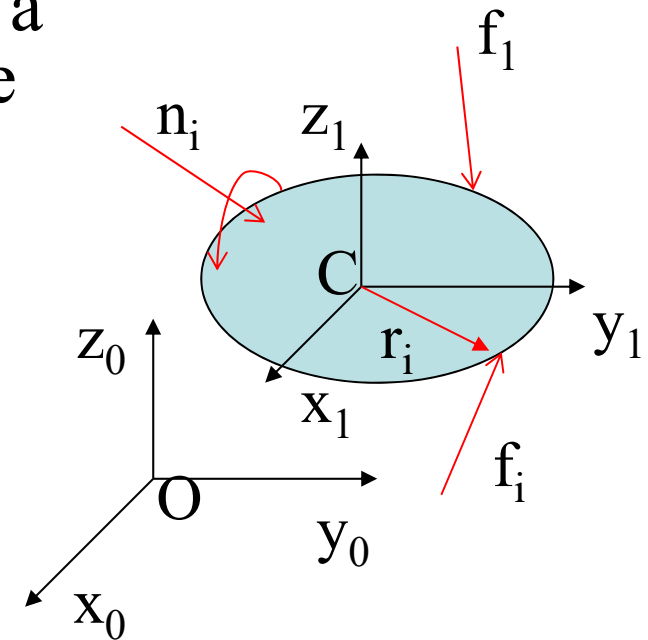

The equation of translation:

$$m\mathbf{a}_c = \mathbf{F} = \sum \mathbf{f}_i$$

Newton's equation

The equation of motion about C:

$$\frac{d}{dt} {}^A \mathbf{H}_C = \mathbf{M}_C \Rightarrow {}^A \mathbf{I} \dot{\boldsymbol{\omega}} + \boldsymbol{\omega} \times ({}^A \mathbf{I} \boldsymbol{\omega}) = \sum \mathbf{r}_i \times \mathbf{f}_i + \sum \mathbf{n}_i$$

Euler's equation

Newton's Equation and Euler's Equation (Cont')

- The angular velocity is with respect to the translating frame.
- The inertia tensor matrix is with respect to the translating frame, so it will change its value with rotation of the body.
- The force is the resultant of the **EXTERNAL** force
- The moment is the resultant moment of the **EXTERNAL** forces and moments.

Example

- Derive the dynamic equation of the 2 DOF manipulator. Here, the masses of links 1 and 2 are m_1 and m_2 respectively. Assume that the mass is uniformly distributed over the link.

Solution:

(1) Analyzing forces acting on the links

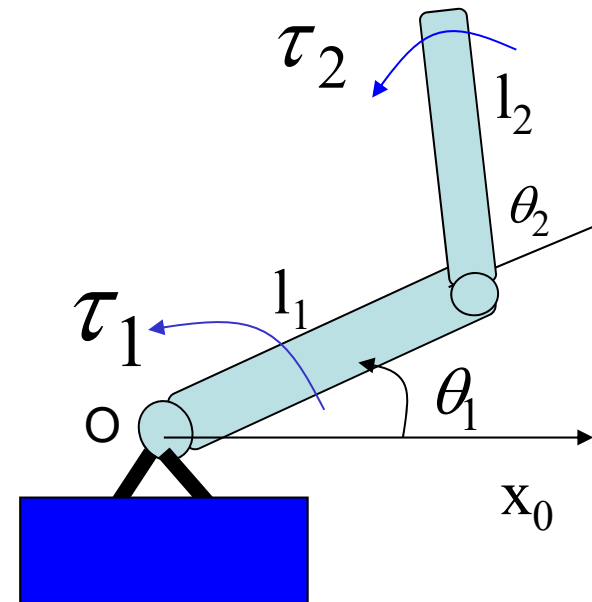
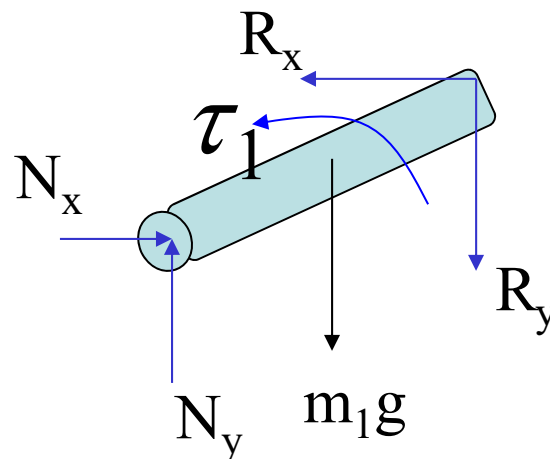
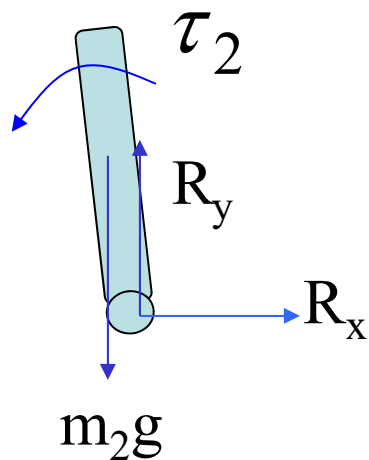

Example (continued)

(2) Dynamics of link 1. As link 1 is rotating about O,

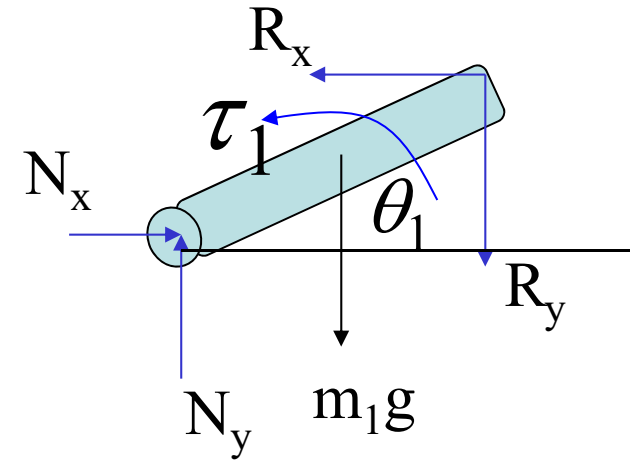

$$I_O \dot{\omega}_1 = M_o$$

Moment of inertia about O

Resultant moment about O

⇓

$$I_O \ddot{\theta}_1 = \tau_1 - m_1 g \frac{l_1}{2} \cos \theta_1 - R_y l_1 \cos \theta_1 + R_x l_1 \sin \theta_1 \quad (1)$$

Example

(3) Dynamics of link 2.

As link 2 is in a general plane motion

$$m_2 \mathbf{a}_{C_2} = \mathbf{F}$$

$${}^C \mathbf{I}_2 \dot{\boldsymbol{\omega}}_2 + \boldsymbol{\omega}_2 \times {}^C \mathbf{I}_2 \boldsymbol{\omega}_2 = \mathbf{M}_{C_2}$$

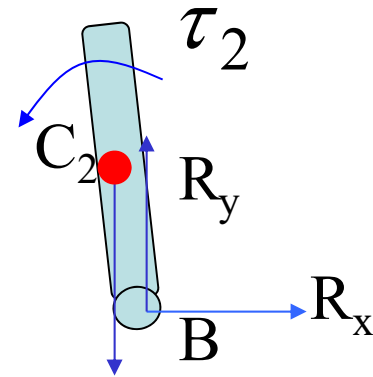

Acceleration of C2: $\mathbf{a}_{C_2} = \mathbf{a}_B + \mathbf{a}_{C/Bt} + \mathbf{a}_{C/Bn}$ $m_2 g$

$$\mathbf{a}_B = \mathbf{a}_{Bn} + \mathbf{a}_{Bt} = \begin{pmatrix} -l_1 \dot{\theta}_1^2 c_1 \\ -l_1 \dot{\theta}_1^2 s_1 \end{pmatrix} + \begin{pmatrix} -l_1 \ddot{\theta}_1 s_1 \\ l_1 \dot{\theta}_1 c_1 \end{pmatrix} = \dots$$

$$\mathbf{a}_{C/Bn} = \frac{l_2}{2} (\dot{\theta}_1 + \dot{\theta}_2)^2 \begin{pmatrix} -c_{12} \\ -s_{12} \end{pmatrix} \quad \mathbf{a}_{C/Bt} = \frac{l_2}{2} (\ddot{\theta}_1 + \ddot{\theta}_2) \begin{pmatrix} -s_{12} \\ c_{12} \end{pmatrix}$$

$$\mathbf{a}_{C_2} = \begin{pmatrix} -l_1 (\ddot{\theta}_1 s_1 + \dot{\theta}_1^2 c_1) - \frac{l_2}{2} (\ddot{\theta}_1 + \ddot{\theta}_2) s_{12} - \frac{l_2}{2} (\dot{\theta}_1 + \dot{\theta}_2)^2 c_{12} \\ -l_1 (\ddot{\theta}_1 c_1 - \dot{\theta}_1^2 s_1) + \frac{l_2}{2} (\ddot{\theta}_1 + \ddot{\theta}_2) c_{12} - \frac{l_2}{2} (\dot{\theta}_1 + \dot{\theta}_2)^2 s_{12} \end{pmatrix}$$

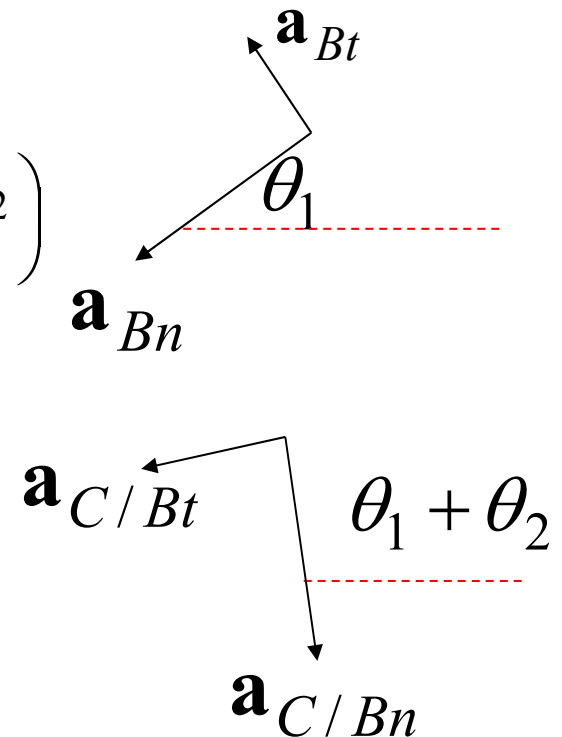

Newton's equation: $m_2 a_{c_2x} = R_x$ (2)

$m_2 a_{c_2y} = R_y - m_2 g$ (3)

Example (continued)

Consider Euler's equation.

As the mass is uniformly distributed and the link is symmetric, the inertia tensor matrix is diagonal.

$$\begin{pmatrix} I_{2xx} & 0 & 0 \\ 0 & I_{2yy} & 0 \\ 0 & 0 & I_{2zz} \end{pmatrix} \begin{pmatrix} 0 \\ 0 \\ \ddot{\theta}_1 + \ddot{\theta}_2 \end{pmatrix} + \begin{pmatrix} 0 \\ 0 \\ \dot{\theta}_1 + \dot{\theta}_2 \end{pmatrix} \times \begin{pmatrix} I_{2xx} & 0 & 0 \\ 0 & I_{2yy} & 0 \\ 0 & 0 & I_{2zz} \end{pmatrix} \begin{pmatrix} 0 \\ 0 \\ \dot{\theta}_1 + \dot{\theta}_2 \end{pmatrix} = \begin{pmatrix} 0 \\ 0 \\ \tau_2 + \frac{l_2}{2} R_x s_{12} + \frac{l_2}{2} R_y c_{12} \end{pmatrix}$$

⇓

$$I_{2zz} (\ddot{\theta}_1 + \ddot{\theta}_2) = \tau_2 + \frac{l_2}{2} R_x s_{12} + \frac{l_2}{2} R_y c_{12} \quad (4)$$

From (2) and (3), we can solve R_x and R_y .

Substituting R_x and R_y in eqs. (1) and (4) leads to the dynamic equation of the robot arm.

Formulation of Robot Dynamics

Recursive Newton-Euler Formulation

We consider manipulators with revolute joints only.

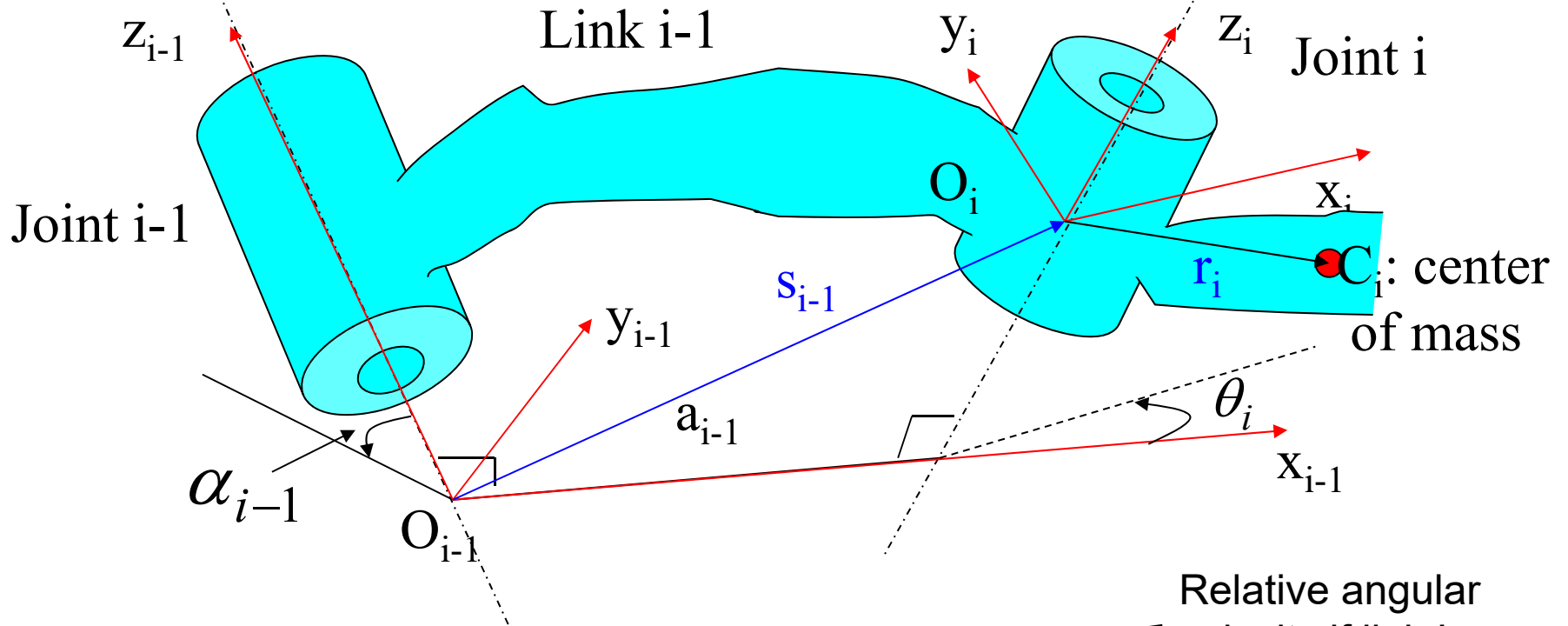

Angular velocity relation between link $i-1$ and i :

$$\boldsymbol{\omega}_i = \boldsymbol{\omega}_{i-1} + \boldsymbol{\omega}_{i/i-1}$$

← Relative angular velocity of link i to link $i-1$

$$\boldsymbol{\omega}_i = \boldsymbol{\omega}_{i-1} + \mathbf{z}_i \dot{\theta}_i \quad (1)$$

Differentiating (1) →

$$\dot{\boldsymbol{\omega}}_i = \dot{\boldsymbol{\omega}}_{i-1} + \mathbf{z}_i \ddot{\theta}_i + \boldsymbol{\omega}_{i-1} \times \mathbf{z}_i \dot{\theta}_i \quad (2)$$

Recursive Newton-Euler Equation (Cont')

- Consider velocity and acceleration of O_i .

$$\begin{aligned} \mathbf{V}_i &: \text{velocity of } O_i \\ \mathbf{V}_{i-1} &: \text{velocity of } O_{i-1} \\ \mathbf{V}_{i/i-1} &: \text{relative velocity of } O_i \text{ to } O_{i-1} \end{aligned} \quad \mathbf{V}_i = \mathbf{V}_{i-1} + \mathbf{V}_{i/i-1}$$

As the relative motion of O_i w.r.t. O_{i-1} is a motion about O_{i-1} ,

$$\mathbf{V}_{i/i-1} = \boldsymbol{\omega}_{i-1} \times \mathbf{s}_{i-1} \quad \Rightarrow \quad \mathbf{V}_i = \mathbf{V}_{i-1} + \boldsymbol{\omega}_{i-1} \times \mathbf{s}_{i-1} \quad (3)$$

Acceleration

at O_i :

$$\begin{aligned} \mathbf{a}_i &= \mathbf{a}_{i-1} + \mathbf{a}_{Rt} + \mathbf{a}_{Rn} \\ &= \mathbf{a}_{i-1} + \dot{\boldsymbol{\omega}}_{i-1} \times \mathbf{s}_{i-1} + \boldsymbol{\omega}_{i-1} \times (\boldsymbol{\omega}_{i-1} \times \mathbf{s}_{i-1}) \end{aligned} \quad (4)$$

Acceleration at the
center of mass:

$$\begin{aligned} \mathbf{a}_{C_i} &= \mathbf{a}_i + \mathbf{a}_{C_i/O_i} \\ &= \mathbf{a}_i + \dot{\boldsymbol{\omega}}_i \times \mathbf{r}_i + \boldsymbol{\omega}_i \times (\boldsymbol{\omega}_i \times \mathbf{r}_i) \end{aligned} \quad (5)$$

Forward Equations

$$\boldsymbol{\omega}_i = \boldsymbol{\omega}_{i-1} + \mathbf{z}_i \dot{\theta}_i \quad (1)$$

$$\dot{\boldsymbol{\omega}}_i = \dot{\boldsymbol{\omega}}_{i-1} + \mathbf{z}_i \ddot{\theta}_i + \boldsymbol{\omega}_{i-1} \times \mathbf{z}_i \dot{\theta}_i \quad (2)$$

$$\mathbf{a}_i = \mathbf{a}_{i-1} + \dot{\boldsymbol{\omega}}_{i-1} \times \mathbf{s}_{i-1} + \boldsymbol{\omega}_{i-1} \times (\boldsymbol{\omega}_{i-1} \times \mathbf{s}_{i-1}) \quad (3)$$

$$\mathbf{a}_{C_i} = \mathbf{a}_i + \dot{\boldsymbol{\omega}}_i \times \mathbf{r}_{i-1} + \boldsymbol{\omega}_i \times (\boldsymbol{\omega}_i \times \mathbf{r}_{i-1}) \quad (4)$$

From (1), (2), (4) and (5), we can recursively calculate the angular velocity and acceleration of the links, and the acceleration at the center of mass.

The initial conditions:

When $i = 0$,

$$\boldsymbol{\omega}_0 = \mathbf{0}, \quad \dot{\boldsymbol{\omega}}_0 = \mathbf{0}$$

$$\mathbf{V}_0 = \mathbf{0}, \quad \mathbf{a}_0 = \mathbf{0}$$

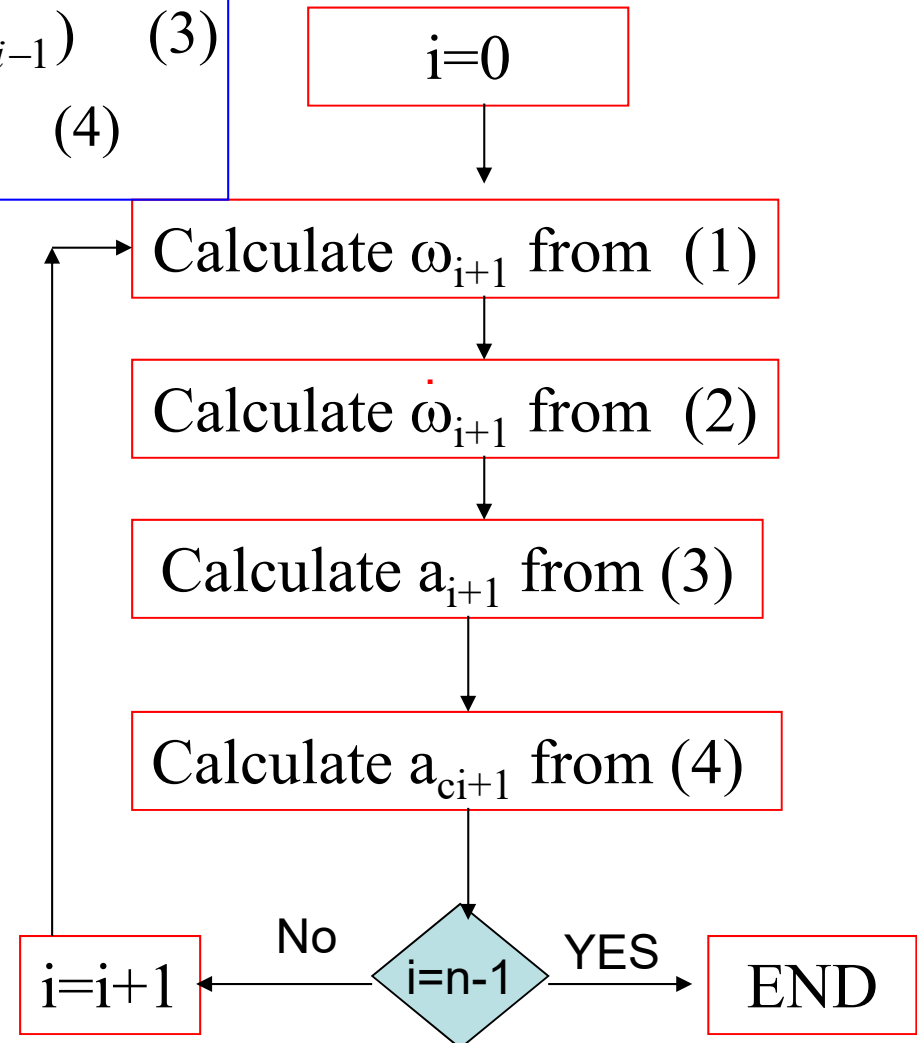

Dynamic equation of robot link

Derive the dynamics by applying Newton-Euler equations to link i .

(1) Draw the free-body diagram of link i . Assume that the links are rigidly connected. Cut link i from the arm:

\mathbf{f}_i : the force acting on link i by link $i-1$

\mathbf{n}_i : the moment applied on link i by link $i-1$

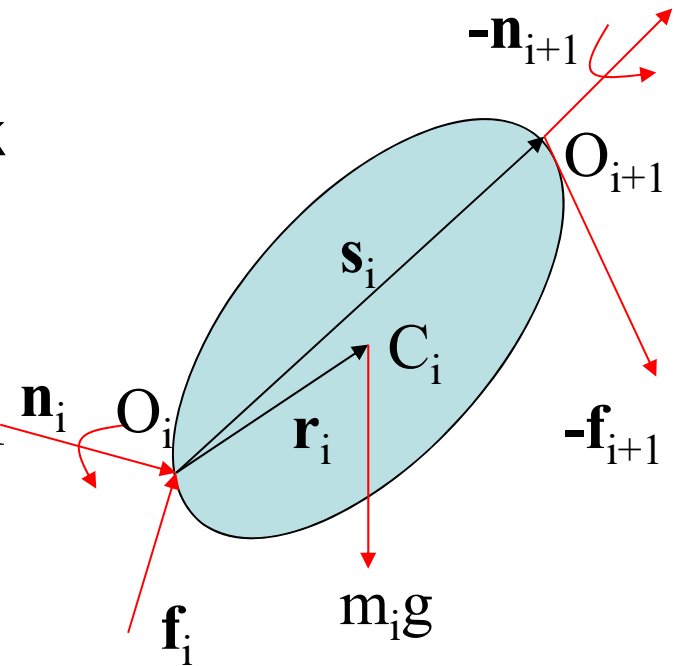

Applying Newton's Law

$$m_i \mathbf{a}_{c_i} = \mathbf{f}_i - \mathbf{f}_{i+1} + \begin{pmatrix} 0 \\ 0 \\ -m_i g \end{pmatrix}$$

$$\Rightarrow \mathbf{f}_i = m_i \mathbf{a}_{c_i} + \mathbf{f}_{i+1} + \begin{pmatrix} 0 \\ 0 \\ m_i g \end{pmatrix} \quad (7)$$

Dynamics of robot link (Cont')

Applying the Euler's equation

$$\mathbf{I}_i \dot{\boldsymbol{\omega}}_i + \boldsymbol{\omega}_i \times \mathbf{I}_i \boldsymbol{\omega}_i = \mathbf{n}_i - \mathbf{n}_{i+1} - \mathbf{r}_i \times \mathbf{f}_i - (\mathbf{s}_i - \mathbf{r}_i) \times \mathbf{f}_{i+1}$$

⇓

$$\mathbf{n}_i = \mathbf{I}_i \dot{\boldsymbol{\omega}}_i + \boldsymbol{\omega}_i \times \mathbf{I}_i \boldsymbol{\omega}_i + \mathbf{n}_{i+1} + \mathbf{r}_i \times \mathbf{f}_i + (\mathbf{s}_i - \mathbf{r}_i) \times \mathbf{f}_{i+1} \quad (8)$$

Eqs. (7) and (8) give the recursive **backward equation** for calculating the interaction force and moment

Relation between \mathbf{n}_i and joint torque

$$\tau_i = \mathbf{z}_i^T \mathbf{n}_i$$

as actuator produces torque about the joint axis only

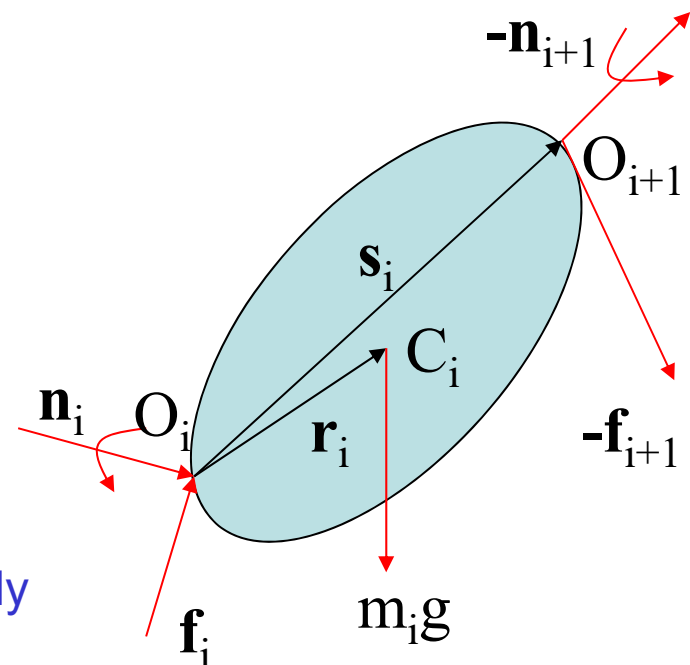

Backward Calculation

Initial conditions: When $i = k$ (for the last link) : $\mathbf{f}_{k+1} = 0, \mathbf{n}_{k+1} = 0$
 k : the number of links

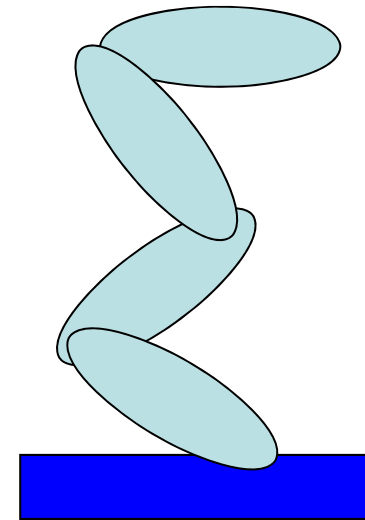
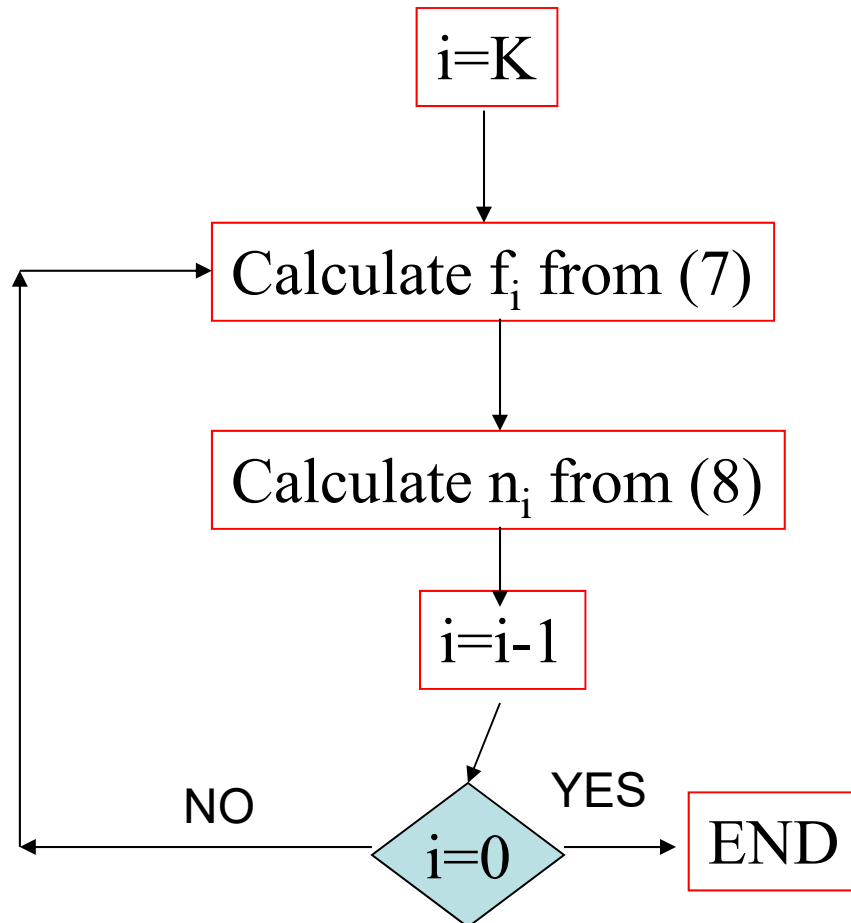

Lagrange Formulation of Robot Dynamics

- Lagrange formulation is an analytical method for deriving the robot dynamics. It is based on the energy and work principle
- Energy of Mechanical Systems
 - Kinetic energy: energy due to motion of a particle or body
 - Potential energy: due to gravitational forces, deformation of mechanical systems, etc.

Kinetic Energy

- A particle (body) has kinetic energy when it moves. Kinetic energy is always greater than zero

For a particle:
$$K = \frac{1}{2} m V^2$$

For a system of particles:
$$K = \sum \frac{1}{2} m_i V_i^2$$

For a rigid body:
$$K = \int_V \frac{1}{2} \dot{\mathbf{r}}^T \dot{\mathbf{r}} dm$$
$$= \frac{1}{2} m V_c^2 + \frac{1}{2} \boldsymbol{\omega}^T \mathbf{I} \boldsymbol{\omega}$$

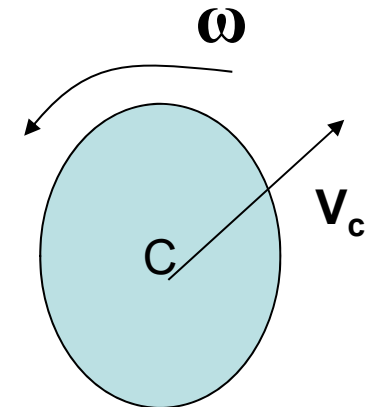
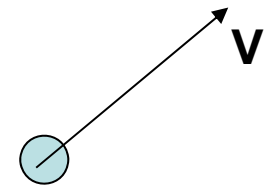

I: inertia tensor

Potential Energy

- We here consider the gravitational potential energy only.

For a particle : $U = mgz$

z : the height of the particle w.r.t. a reference level

For a system of particles : $U = \sum m_i g z_i$

For a rigid body : $U = mgz_c$



The diagram shows a light blue circle representing a particle. A horizontal line passes through the center of the circle. Below this line is another horizontal line representing a reference level. A vertical arrow points upwards from the reference level to the center of the particle, and is labeled with the letter 'z'. An arrow points from the text 'The height of the center of mass' to the center of the particle.

The height of the center of mass

**Potential energy is a value relative to the reference.
It could be positive, zero and negative**

Work

When a particle underwent a displacement \mathbf{r} under a constant force \mathbf{f} , the work done by the force on the particle is

$$W = \mathbf{f}^T \mathbf{r}$$

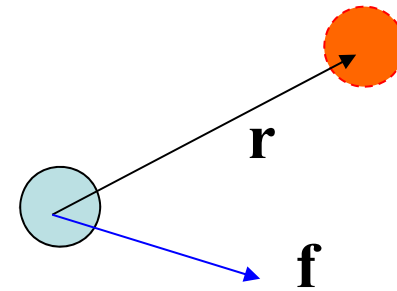

- Work is a scalar
- It could be positive, zero and negative
- SI unit: Nm

Work done by time-varying force

Consider the work done by a time-varying force on a particle that moved from one position to another.

$$\begin{aligned} W &= \int_1^2 \mathbf{f}^T(t) d\mathbf{r} \\ &= \int_1^2 m \frac{d\mathbf{V}}{dt} d\mathbf{r} = \int_1^2 m \mathbf{V} d\mathbf{V} \\ &= \frac{1}{2} m V_2^2 - \frac{1}{2} m V_1^2 \\ &= \Delta K \end{aligned}$$

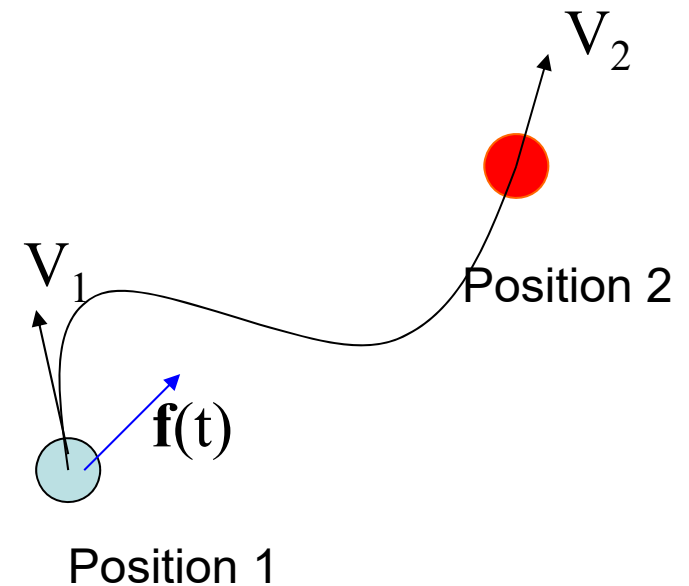

Work-energy principle: The work done by a force acting on particle is equal to the change of its kinetic energy

Conservative force and Non-Conservative force

- The force associated to the potential energy is called conservative force. A force that is not associated with the potential energy is called non-conservative force.
- The work done by conservative force (gravity force)

$$W_g = -mg(z_2 - z_1) = -\Delta U$$

- The work done by non-conservative forces

$$\begin{aligned} W_n + W_g &= \Delta K \\ \Rightarrow W_n &= \Delta K + \Delta U = \Delta(K + U) \end{aligned}$$

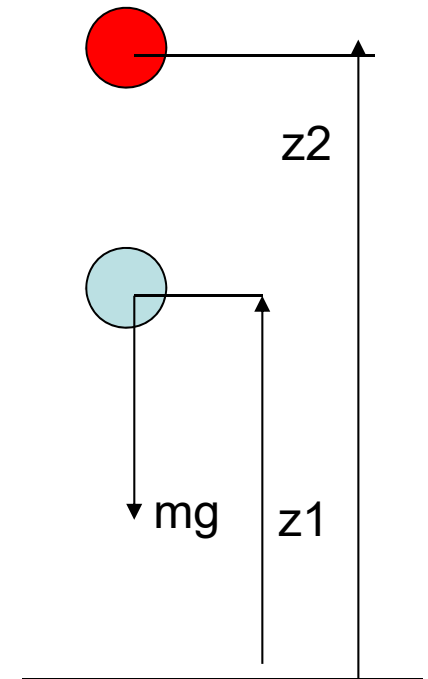

The work done by non-conservative forces is equal to the change of total energy

Conservation of Energy

- If no non-conservative force acting on a system (a particle, or a system of particles, or a rigid body), does not do any work, the total energy of the system is conserved.

$$K + U = \text{constant}$$

Lagrange Equation

- Generalized coordinates \mathbf{q} : A set of parameters for representing the configuration (position & orientation) of a system.
 - \mathbf{q} must specify the configuration uniquely
 - Once the values of \mathbf{q} are fixed, the system cannot move.
 - The choice of \mathbf{q} is not unique.
- Degree of freedom (DOF): The dimension of the generalized coordinates vector \mathbf{q} is called degrees of freedom of the system

Examples

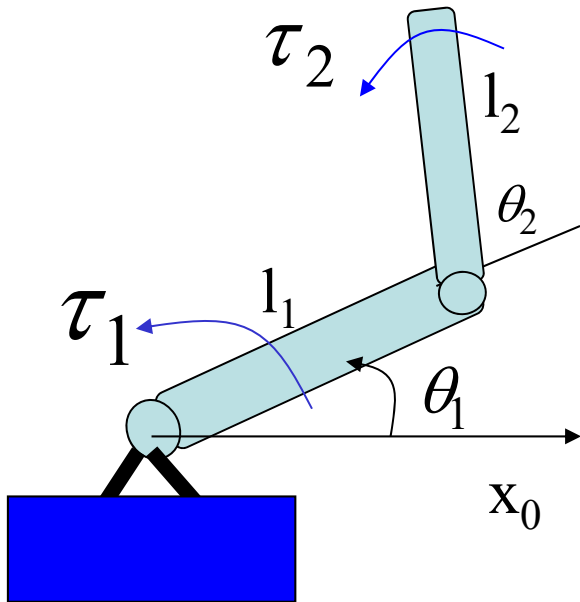

$$\mathbf{q} = \begin{pmatrix} \theta_1 \\ \theta_2 \end{pmatrix}$$

DOF = 2

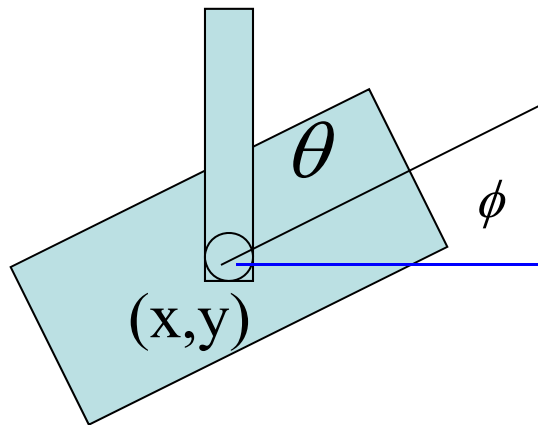

$$\mathbf{q} = \begin{pmatrix} x \\ y \\ \phi \\ \theta \end{pmatrix}$$

DOF=4

Generalized Force

Consider the work done by non-conservative forces under a differential displacement of the system

$\delta \mathbf{r}_i$: differential displacement at the action point of \mathbf{f}_i due to a differential change $\delta \mathbf{q}$ of the generalized coordinates \mathbf{q}

The differential work δW :

$$\delta W = \sum \mathbf{f}_i^T \delta \mathbf{r}_i$$

The generalized force \mathbf{F} of the system is given by

$$\mathbf{F} = \frac{\partial}{\partial(\delta \mathbf{q})} (\delta W) \quad \mathbf{q} : \text{generalized coordinates vector}$$

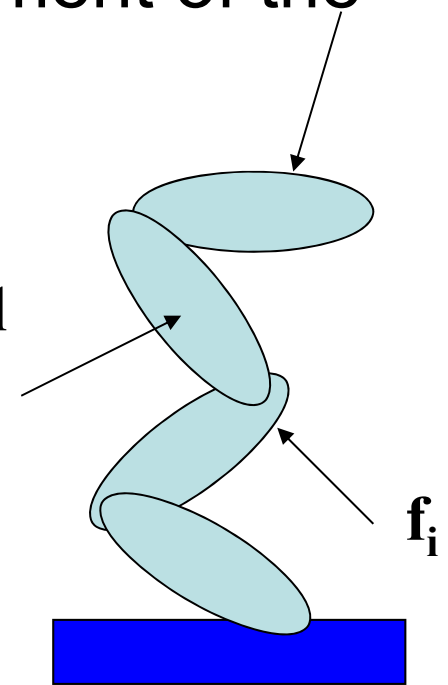

Example

Calculate the generalized force of the 2 DOF arm

Generalized Coordinates : $\mathbf{q} = \begin{pmatrix} \theta_1 \\ \theta_2 \end{pmatrix}$

For differential motion $\delta\mathbf{q} = (\delta\theta_1, \delta\theta_2)^T$

The differential work

$$\delta W = \tau_1 \delta\theta_1 + \tau_2 \delta\theta_2 + \mathbf{f}^T \delta\mathbf{x}$$

$\delta\mathbf{x}$: the differential motion of the end point

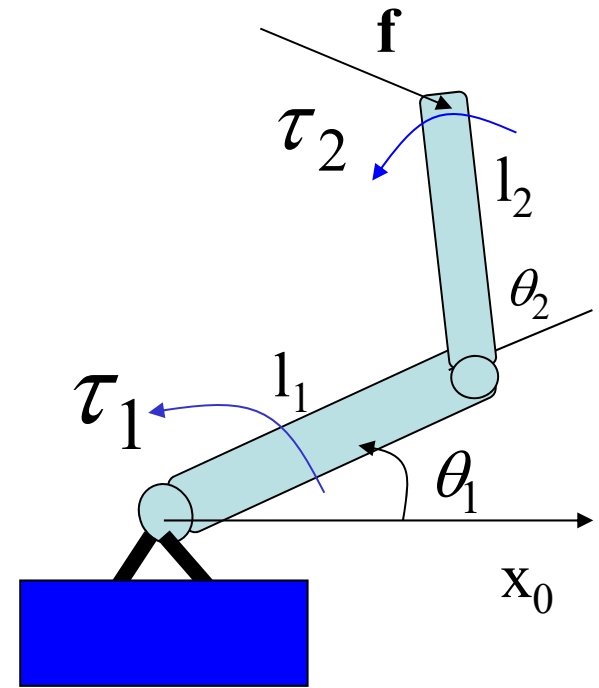

$$\because \delta\mathbf{x} = J(\mathbf{q})\delta\mathbf{q} \quad \longrightarrow \quad \therefore \delta W = \tau_1 \delta\theta_1 + \tau_2 \delta\theta_2 + \mathbf{f}^T J(\mathbf{q})\delta\mathbf{q} \\ = (\tau_1 \quad \tau_2)\delta\mathbf{q} + (J(\mathbf{q})\mathbf{f})^T \delta\mathbf{q}$$

Generalized Force:

Lagrange Equation

q: the generalized coordinates of a system

K: Kinetic energy of the system

U: the potential energy of the system

F: the generalized forces of the system

Define $L=K-U$: Called Lagrangian

The dynamics of the system is given by

$$\frac{d}{dt} \frac{\partial L}{\partial \dot{\mathbf{q}}} - \frac{\partial L}{\partial \mathbf{q}} = \mathbf{F}$$

Derivation of Robot Dynamics using Lagrange Equation

- 1) Choose the generalized coordinates \mathbf{q} (usually use the kinematics parameters defined by the D-H method)
- 2) Identify the non-conservative forces that are exerted at the system and do work
- 3) Calculate the kinetic energy K and the potential energy U , and then $L=K-U$
- 4) Calculate the partial derivatives
- 5) Calculate the generalized force \mathbf{F} .
- 6) Apply the Lagrange equation.

Example 1

Example: Denote the mass of link i by m_i . The mass is uniformly distributed over the link. Derive the dynamics of the 2 DOF arm.

Solution (1) Generalized coordinates: $\mathbf{q} = \begin{pmatrix} \theta_1 \\ \theta_2 \end{pmatrix}$

(2) Non-conservative forces that do work: τ_1, τ_2

(3) The kinetic energy:

\therefore link 1 rotates about O, $\therefore K_1 = \frac{1}{2} I_o \dot{\theta}_1^2$

\therefore link 2 in general plane motion, $\therefore K_2 = \frac{1}{2} m_2 V_{c_2}^2 + \frac{1}{2} I_{c_2} \omega_2^2$

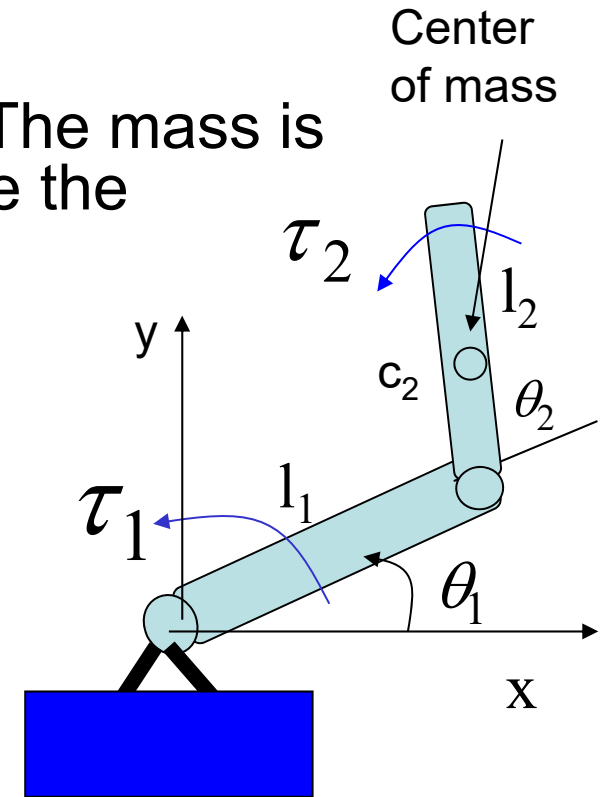

Position of the Center Of mass

$$\begin{cases} x_{c_2} = l_1 c_1 + \frac{l_2}{2} c_{12} \\ y_{c_2} = l_1 s_1 + \frac{l_2}{2} s_{12} \end{cases} \Rightarrow V_{c_2}^2 = \dot{x}_{c_2}^2 + \dot{y}_{c_2}^2 = l_1^2 \dot{\theta}_1^2 + \frac{l_2^2}{4} (\dot{\theta}_1 + \dot{\theta}_2)^2 + l_1 l_2 c_2 \dot{\theta}_1 (\dot{\theta}_1 + \dot{\theta}_2)$$

Example 1 (continued)

The total kinetic energy

$$K = K_1 + K_2 = \frac{1}{2}(I_o + m_2 l_1^2) \dot{\theta}_1^2 + \frac{1}{2} m_2 l_1 l_2 c_2 \dot{\theta}_1 (\dot{\theta}_1 + \dot{\theta}_2) + \left(\frac{1}{8} m_2 l_2^2 + \frac{1}{2} I_{c_2} \right) (\dot{\theta}_1 + \dot{\theta}_2)^2$$

The potential energy (assume $y=0$ is the reference)

$$U = m_1 g y_{c1} + m_2 g y_{c2} = m_1 g \frac{l_1}{2} s_1 + m_2 g \left(l_1 s_1 + \frac{l_2}{2} s_{12} \right)$$

(4) Calculate the partial derivatives

$$\frac{\partial L}{\partial \dot{\theta}_1} = (I_o + m_2 l_1^2) \dot{\theta}_1 + m_2 l_1 l_2 c_2 (\dot{\theta}_1 + \frac{1}{2} \dot{\theta}_2) + \left(\frac{1}{4} m_2 l_2^2 + I_{c_2} \right) (\dot{\theta}_1 + \dot{\theta}_2)$$

$$\frac{\partial L}{\partial \dot{\theta}_2} = \frac{1}{2} m_2 l_1 l_2 c_2 \dot{\theta}_1 + \left(\frac{1}{4} m_2 l_2^2 + I_{c_2} \right) (\dot{\theta}_1 + \dot{\theta}_2)$$

$$\frac{\partial L}{\partial \theta_1} = -m_1 g \frac{l_1}{2} c_1 - m_2 g \left(l_1 c_1 + \frac{l_2}{2} c_{12} \right)$$

$$\frac{\partial L}{\partial \theta_2} = -m_2 g \frac{l_2}{2} c_{12} - \frac{1}{2} m_2 l_1 l_2 s_2 \dot{\theta}_1 (\dot{\theta}_1 + \dot{\theta}_2)$$

Example 1 (continued)

5) The generalized forces:

$$\delta W = \tau_1 \delta \theta_1 + \tau_2 \delta \theta_2 \quad \Rightarrow \quad \mathbf{F} = \begin{pmatrix} \tau_1 \\ \tau_2 \end{pmatrix}$$

6) Apply the Lagrange equation: $\frac{d}{dt} \frac{\partial L}{\partial \dot{\mathbf{q}}} - \frac{\partial L}{\partial \mathbf{q}} = \mathbf{F}$

$$\begin{pmatrix} I_{o1} + m_2 l_1^2 + 0.25 m_2 l_2^2 + I_{c2} + m_2 l_1 l_2 c_2 & 0.25 m_2 l_2^2 + I_{c2} + 0.5 m_2 l_1 l_2 c_2 \\ 0.25 m_2 l_2^2 + I_{c2} + 0.5 m_2 l_1 l_2 c_2 & 0.25 m_2 l_2^2 + I_{c2} \end{pmatrix} \begin{pmatrix} \ddot{\theta}_1 \\ \ddot{\theta}_2 \end{pmatrix} + \begin{pmatrix} -m_2 l_1 l_2 s_2 (\dot{\theta}_1 + 0.5 \dot{\theta}_2) \dot{\theta}_2 + (0.5 m_1 + m_2) l_1 g c_1 + 0.5 m_2 l_2 g c_{12} \\ 0.5 m_2 l_1 l_2 s_2 \dot{\theta}_1^2 + 0.5 m_2 l_2 g c_{12} \end{pmatrix} = \begin{pmatrix} \tau_1 \\ \tau_2 \end{pmatrix}$$

Example 2

Example 2: The moment of inertia of the first link is I_1 . The mass of link 2 is m_2 . The mass is concentrated at the endpoint. An external force f acts at the endpoint. Derive the dynamics of the arm.

Solution: (1) Generalized coordinates

Use the D-H method to assign frames and select the joint angles as the generalized coordinates

i	α_{i-1}	a_{i-1}	d_i	θ_i
1	0	0	0	θ_1
2	90°	0	0	θ_2
3	0	l_2	0	0

Generalized coordinates:

$$\mathbf{q} = \begin{pmatrix} \theta_1 \\ \theta_2 \end{pmatrix}$$

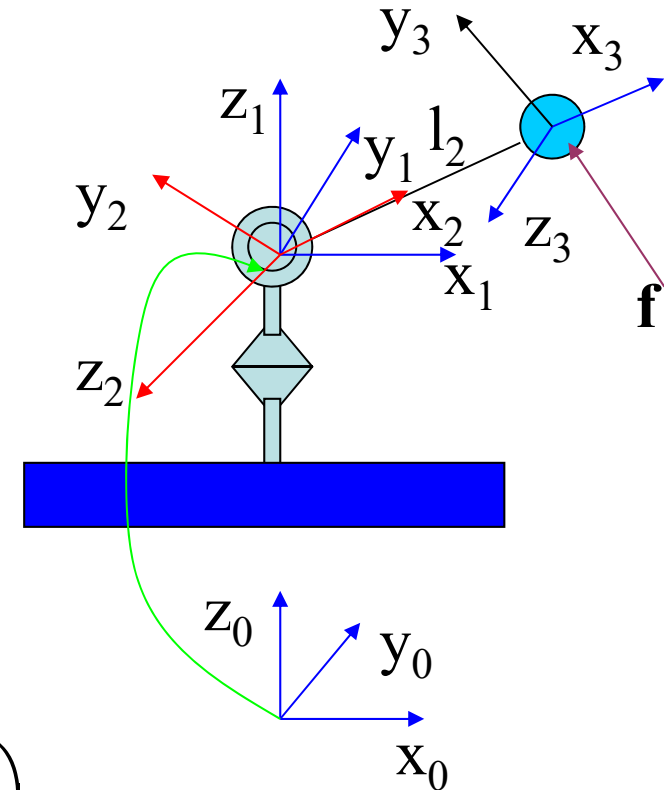

Example 2 (continued)

(2) No-conservative forces that do work:

joint inputs : τ_1, τ_2 , and the external force \mathbf{f}

(3) Kinetic energy, potential energy and Lagrangian

Kinetic energy:

$$\text{Link 1: } K_1 = \frac{1}{2} I_1 \dot{\theta}_1^2 \quad \text{Link 2: } K_2 = \frac{1}{2} m_2 V^2$$

To find the velocity V of the endpoint, we need to solve the forward kinematics

$${}^0T_1 = \begin{pmatrix} c_1 & -s_1 & 0 & 0 \\ s_1 & c_1 & 0 & 0 \\ 0 & 0 & 1 & 0 \\ 0 & 0 & 0 & 1 \end{pmatrix} \quad {}^1T_2 = \begin{pmatrix} c_2 & -s_2 & 0 & 0 \\ 0 & 0 & -1 & 0 \\ s_2 & c_2 & 0 & 0 \\ 0 & 0 & 0 & 1 \end{pmatrix} \quad {}^2T_3 = \begin{pmatrix} 1 & 0 & 0 & l_2 \\ 0 & 1 & 0 & 0 \\ 0 & 0 & 1 & 0 \\ 0 & 0 & 0 & 1 \end{pmatrix}$$

Example 2 (continued)

Forward kinematics:

$${}^0T_2 = {}^0T_1 {}^1T_2 = \begin{pmatrix} c_1 c_2 & -c_1 s_2 & s_1 & 0 \\ s_1 c_2 & -s_1 s_2 & -c_1 & 0 \\ s_2 & c_2 & 0 & 0 \\ 0 & 0 & 0 & 1 \end{pmatrix} \quad {}^0T_3 = {}^0T_2 {}^2T_3 = \begin{pmatrix} c_1 c_2 & -c_1 s_2 & s_1 & l_2 c_1 c_2 \\ s_1 c_2 & -s_1 s_2 & -c_1 & l_2 s_1 c_2 \\ s_2 & c_2 & 0 & l_2 s_2 \\ 0 & 0 & 0 & 1 \end{pmatrix}$$

$$\mathbf{V} = \frac{d}{dt} \begin{pmatrix} l_2 c_1 c_2 \\ l_2 s_1 c_2 \\ l_2 s_2 \end{pmatrix} \Rightarrow V^2 = l_2^2 c_2^2 \dot{\theta}_1^2 + l_2^2 \dot{\theta}_2^2$$

The potential energy (Assuming that $U=0$ when $z_0=0$).

$$U = -m_1 g h_1 + m_2 g l_2 s_2$$

Lagrangian:

$$L = K - U = \frac{1}{2} (I_1 + m_2 l_2^2 c_2^2) \dot{\theta}_1^2 + \frac{1}{2} m_2 l_2^2 \dot{\theta}_2^2 + m_1 g h_1 - m_2 g l_2 s_2$$

Example 2 (continued)

(4) Calculate the partial derivatives

$$\frac{\partial L}{\partial \dot{\theta}_1} = (I_1 + m_2 l_2^2 c_2^2) \dot{\theta}_1$$

$$\frac{\partial L}{\partial \dot{\theta}_2} = m_2 l_2^2 \dot{\theta}_2$$

$$\frac{\partial L}{\partial \theta_1} = 0$$

$$\frac{\partial L}{\partial \theta_2} = -\frac{1}{2} m_2 l_2^2 \sin 2\theta_2 \dot{\theta}_1^2 - m_2 g l_2 c_2$$

Example 2 (continued)

(5) Generalized forces:

$$\delta W = \tau_1 \delta \theta_1 + \tau_2 \delta \theta_2 + \mathbf{f}^T \delta \mathbf{x} \Rightarrow \mathbf{F} = \begin{pmatrix} \tau_1 \\ \tau_2 \end{pmatrix} + \mathbf{J}^T(\mathbf{q}) \mathbf{f}$$

\mathbf{x} : the position of the endpoint

$$\mathbf{x} = \begin{pmatrix} l_2 c_1 c_2 \\ l_2 s_1 c_2 \\ l_2 s_2 \end{pmatrix} \Rightarrow \mathbf{J}(\mathbf{q}) = \frac{\partial \mathbf{x}}{\partial \mathbf{q}} = \frac{\partial}{\partial \mathbf{q}} \begin{pmatrix} l_2 c_1 c_2 \\ l_2 s_1 c_2 \\ l_2 s_2 \end{pmatrix} = \begin{pmatrix} -l_2 s_1 c_2 & -l_2 c_1 s_2 \\ l_2 c_1 c_2 & -l_2 s_1 s_2 \\ 0 & l_2 c_2 \end{pmatrix}$$

(6) Applying the Lagrange equation leads to the dynamics:

$$\begin{pmatrix} I_1 + m_2 l_2^2 c_2^2 & 0 \\ 0 & m_2 l_2 \end{pmatrix} \begin{pmatrix} \ddot{\theta}_1 \\ \ddot{\theta}_2 \end{pmatrix} + \begin{pmatrix} 0.5 m_2 l_2^2 \sin 2\theta_2 \dot{\theta}_1 \dot{\theta}_2 \\ 0.5 m_2 l_2^2 \sin 2\theta_2 \dot{\theta}_1^2 \end{pmatrix} + \begin{pmatrix} 0 \\ m_2 g l_2 c_2 \end{pmatrix} \\ = \begin{pmatrix} \tau_1 \\ \tau_2 \end{pmatrix} + \mathbf{J}^T(\mathbf{q}) \mathbf{f}$$

Structure of Robot Dynamics

- The dynamics of the 2 DOF manipulator:

$$\underbrace{\begin{pmatrix} I_{o1} + m_2 l_1^2 + 0.25 m_2 l_2^2 + I_{c2} + m_2 l_1 l_2 c_2 & 0.25 m_2 l_2^2 + I_{c2} + 0.5 m_2 l_1 l_2 c_2 \\ 0.25 m_2 l_2^2 + I_{c2} + 0.5 m_2 l_1 l_2 c_2 & 0.25 m_2 l_2^2 + I_{c2} \end{pmatrix}}_{H(\mathbf{q})} \begin{pmatrix} \ddot{\theta}_1 \\ \ddot{\theta}_2 \end{pmatrix} + \underbrace{\begin{pmatrix} -m_2 l_1 l_2 s_2 (\dot{\theta}_1 + 0.5 \dot{\theta}_2) \dot{\theta}_2 \\ 0.5 m_2 l_1 l_2 s_2 \dot{\theta}_1^2 \end{pmatrix}}_{C(\mathbf{q}, \dot{\mathbf{q}})} + \underbrace{\begin{pmatrix} (0.5 m_1 + m_2) l_1 g c_1 + 0.5 m_2 l_2 g c_{12} \\ 0.5 m_2 l_2 g c_{12} \end{pmatrix}}_{G(\mathbf{q})} = \begin{pmatrix} \tau_1 \\ \tau_2 \end{pmatrix}$$

$H(\mathbf{q})$: Inertia matrix of the manipulator, depending on the joint position $H^T(\mathbf{q}) = H(\mathbf{q})$ ← symmetric matrix

$C(\mathbf{q}, \dot{\mathbf{q}})$: the centrifugal and Coriolis forces

Centrifugal force: Terms that depend on the square of the joint velocity of a joint.

Coriolis force: Terms that depend on the product

of the joint velocities of two joints.

$G(\mathbf{q})$: The gravity force

Structure of Robot Dynamics

- The centrifugal and Coriolis term can be re-written as

$$\mathbf{C}(\mathbf{q}, \dot{\mathbf{q}}) = \begin{pmatrix} -m_2 l_1 l_2 s_2 (\dot{\theta}_1 + 0.5 \dot{\theta}_2) \dot{\theta}_2 \\ 0.5 m_2 l_1 l_2 s_2 \dot{\theta}_1^2 \end{pmatrix}$$

$$= \left\{ \underbrace{\frac{1}{2} \begin{pmatrix} -m_2 l_1 l_2 s_2 \dot{\theta}_2 & -0.5 m_2 l_1 l_2 s_2 \dot{\theta}_2 \\ -0.5 m_2 l_1 l_2 s_2 \dot{\theta}_2 & 0 \end{pmatrix}}_{\frac{1}{2} \dot{\mathbf{H}}(\mathbf{q})} + \underbrace{\begin{pmatrix} 0 & -0.5 m_2 l_1 l_2 s_2 (\dot{\theta}_1 + 0.5 \dot{\theta}_2) \\ 0.5 m_2 l_1 l_2 s_2 (\dot{\theta}_1 + 0.5 \dot{\theta}_2) & 0 \end{pmatrix}}_{\mathbf{S}(\mathbf{q}, \dot{\mathbf{q}})} \right\} \begin{pmatrix} \dot{\theta}_1 \\ \dot{\theta}_2 \end{pmatrix}$$

$\mathbf{S}(\mathbf{q}, \dot{\mathbf{q}})$ is a skew - symmetric matrix, i.e.

$$\mathbf{S}^T(\mathbf{q}, \dot{\mathbf{q}}) = -\mathbf{S}(\mathbf{q}, \dot{\mathbf{q}})$$

$$\text{For any } \mathbf{x}, \quad \mathbf{x}^T \mathbf{S}(\mathbf{q}, \dot{\mathbf{q}}) \mathbf{x} = 0$$

Structure of Robot Dynamics

- In general, the dynamics of a robot manipulator has the following form:

$$\mathbf{H}(\mathbf{q})\ddot{\mathbf{q}} + \left(\frac{1}{2}\dot{\mathbf{H}}(\mathbf{q}) + \mathbf{S}(\mathbf{q}, \dot{\mathbf{q}})\right)\dot{\mathbf{q}} + \mathbf{G}(\mathbf{q}) = \boldsymbol{\tau}$$

Inertial force Centrifugal and Coriolis forces Gravity Joint inputs

$\mathbf{H}(\mathbf{q})$: Symmetric and positive - definite inertial matrix.

$\frac{1}{2}\dot{\mathbf{q}}^T \mathbf{H}(\mathbf{q})\dot{\mathbf{q}}$ is the kinetic energy ≥ 0

$\mathbf{S}(\mathbf{q}, \dot{\mathbf{q}})$: a skew - symmetric matrix

$$\Rightarrow \mathbf{x}^T \mathbf{S}(\mathbf{q}, \dot{\mathbf{q}})\mathbf{x} = 0, \quad \forall \mathbf{x} \in \mathbb{R}^n$$

Linear Parameterization of Robot Dynamics

The dynamics of the 2 DOF arm:

$$\begin{pmatrix} I_{o1} + m_2 l_1^2 + 0.25 m_2 l_2^2 + I_{c2} + m_2 l_1 l_2 c_2 & 0.25 m_2 l_2^2 + I_{c2} + 0.5 m_2 l_1 l_2 c_2 \\ 0.25 m_2 l_2^2 + I_{c2} + 0.5 m_2 l_1 l_2 c_2 & 0.25 m_2 l_2^2 + I_{c2} \end{pmatrix} \begin{pmatrix} \ddot{\theta}_1 \\ \ddot{\theta}_2 \end{pmatrix} + \begin{pmatrix} -m_2 l_1 l_2 s_2 (\dot{\theta}_1 + 0.5 \dot{\theta}_2) \dot{\theta}_2 \\ 0.5 m_2 l_1 l_2 s_2 \dot{\theta}_1^2 \end{pmatrix} + \begin{pmatrix} (0.5 m_1 + m_2) l_1 g c_1 + 0.5 m_2 l_2 g c_{12} \\ 0.5 m_2 l_2 g c_{12} \end{pmatrix} = \begin{pmatrix} \tau_1 \\ \tau_2 \end{pmatrix}$$

Define

$$\left. \begin{aligned} \beta_1 &= I_{o1} + m_2 l_1^2 + 0.25 m_2 l_2^2 + I_{c2} \\ \beta_2 &= 0.25 m_2 l_2^2 + I_{c2} \\ \beta_3 &= 0.5 m_2 l_1 l_2 \\ \beta_4 &= (0.5 m_1 + m_2) l \\ \beta_5 &= 0.5 m_2 l_2 \end{aligned} \right\}$$

The parameters depend on mass, length, moment of inertia. They are the physical parameters

$$\Rightarrow \underbrace{\begin{pmatrix} \ddot{\theta}_1 & \ddot{\theta}_2 & c_2(2\ddot{\theta}_1 + \ddot{\theta}_2) - 2s_2(\dot{\theta}_1 + 0.5\dot{\theta}_2)\dot{\theta}_2 & g c_1 & g c_{12} \\ 0 & \ddot{\theta}_1 + \ddot{\theta}_2 & c_2\ddot{\theta}_1 + s_1\dot{\theta}_1^2 & 0 & g c_{12} \end{pmatrix}}_{Y(\mathbf{q}, \dot{\mathbf{q}}, \ddot{\mathbf{q}})} \underbrace{\begin{pmatrix} \beta_1 \\ \beta_2 \\ \beta_3 \\ \beta_4 \\ \beta_5 \end{pmatrix}}_{\boldsymbol{\beta}} = \begin{pmatrix} \tau_1 \\ \tau_2 \end{pmatrix}$$

The result can be generalized to n DOF robot manipulator

Parameter vector