



Centurion
UNIVERSITY

Shaping Lives...
Empowering Communities...

Electric Vehicle Drive Trains



EV Transmission Configurations

Electric Vehicle (EV) Configurations

Compared to HEV, the configuration of EV is flexible. The reasons for this flexibility are:

- The energy flow in EV is mainly via flexible electrical wires rather than bolted flanges or rigid shafts. Hence, distributed subsystems in the EV are really achievable.
- The EVs allow different propulsion arrangements such as independent four wheel and in wheel drives.

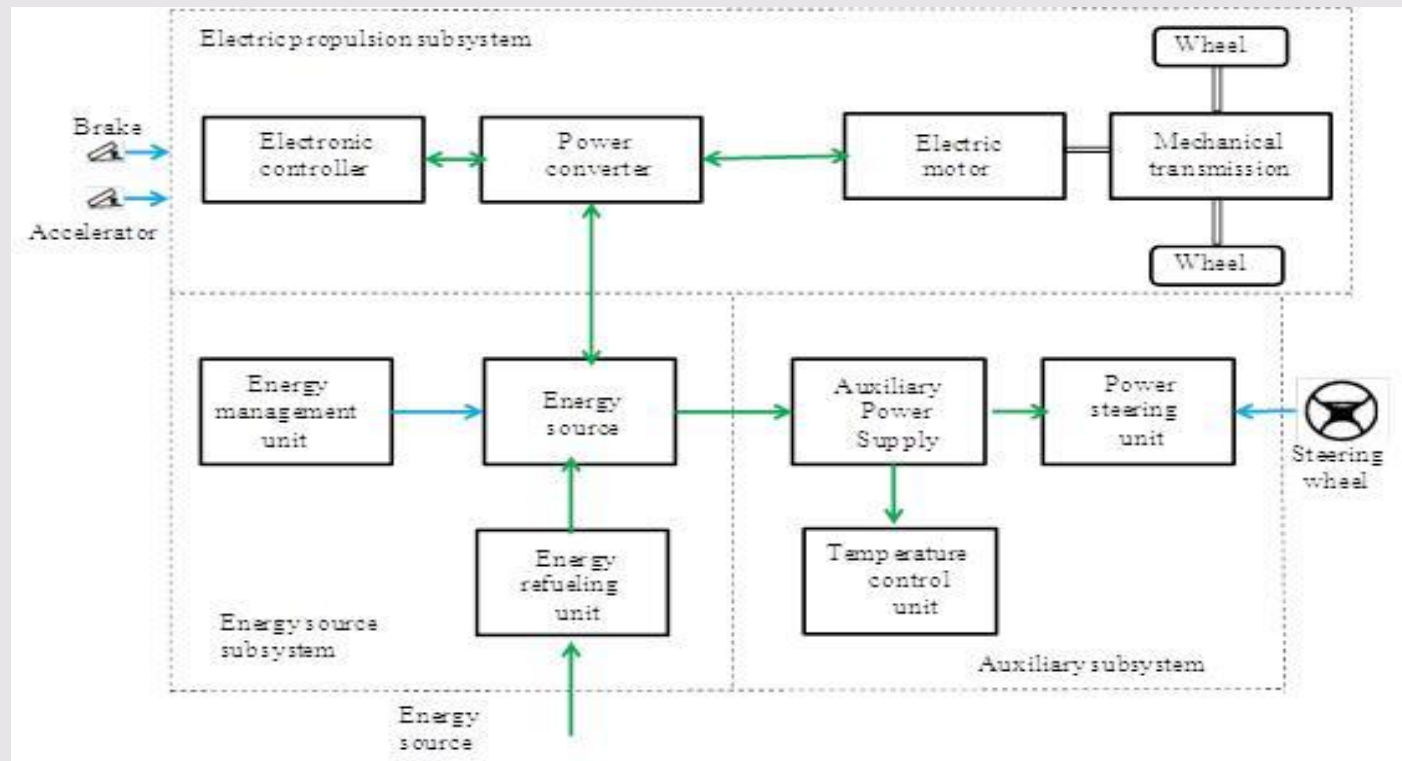



Centurion
UNIVERSITY

*Shaping Lives...
Empowering Communities...*

Cont....

In **Figure 1** the general configuration of the EV is shown. The EV has three major subsystems:

- Electric propulsion
- Energy source
- Auxiliary system

The electric propulsion subsystem comprises of:

- The electronic controller
- Power converter
- Electric Motor (EM)
- Mechanical transmission
- Driving wheels

The energy source subsystem consists of

- The energy source (battery, fuel cell, ultracapacitor)
- Energy management unit
- Energy refueling unit

Cont....



Centurion
UNIVERSITY

*Shaping Lives...
Empowering Communities...*

The auxiliary subsystem consists of

- Power steering unit
- Temperature control unit
- Auxiliary power supply

In **Figure 1** the black line represents the mechanical link, the green line represents the electrical link and the blue line represents the control information communication. Based on the control inputs from the brake and accelerator pedals, the electronic controller provides proper control signals to switch on or off the power converter which in turn regulates the power flow between the electric motor and the energy source. The backward power flow is due to regenerative braking of the EV and this regenerative energy can be stored provided the energy source is receptive.

The energy management unit cooperates with the electronic controller to control regenerative braking and its energy recovery. It also works with the energy-refueling unit to control refueling and to monitor usability of the energy source.

The auxiliary power supply provides the necessary power with different voltage levels for all EV auxiliaries, especially the temperature control and power steering units.



Centurion
UNIVERSITY

*Shaping Lives...
Empowering Communities...*

In modern EV's configuration

- Three phase motors are generally used to provide the traction force
- The power converter is a three-phase PWM inverter
- Mechanical transmission is based on fixed gearing and a differential
- Li-ion battery is typically selected as the energy source

The typical setup of the EV is shown in **Figure 2** .

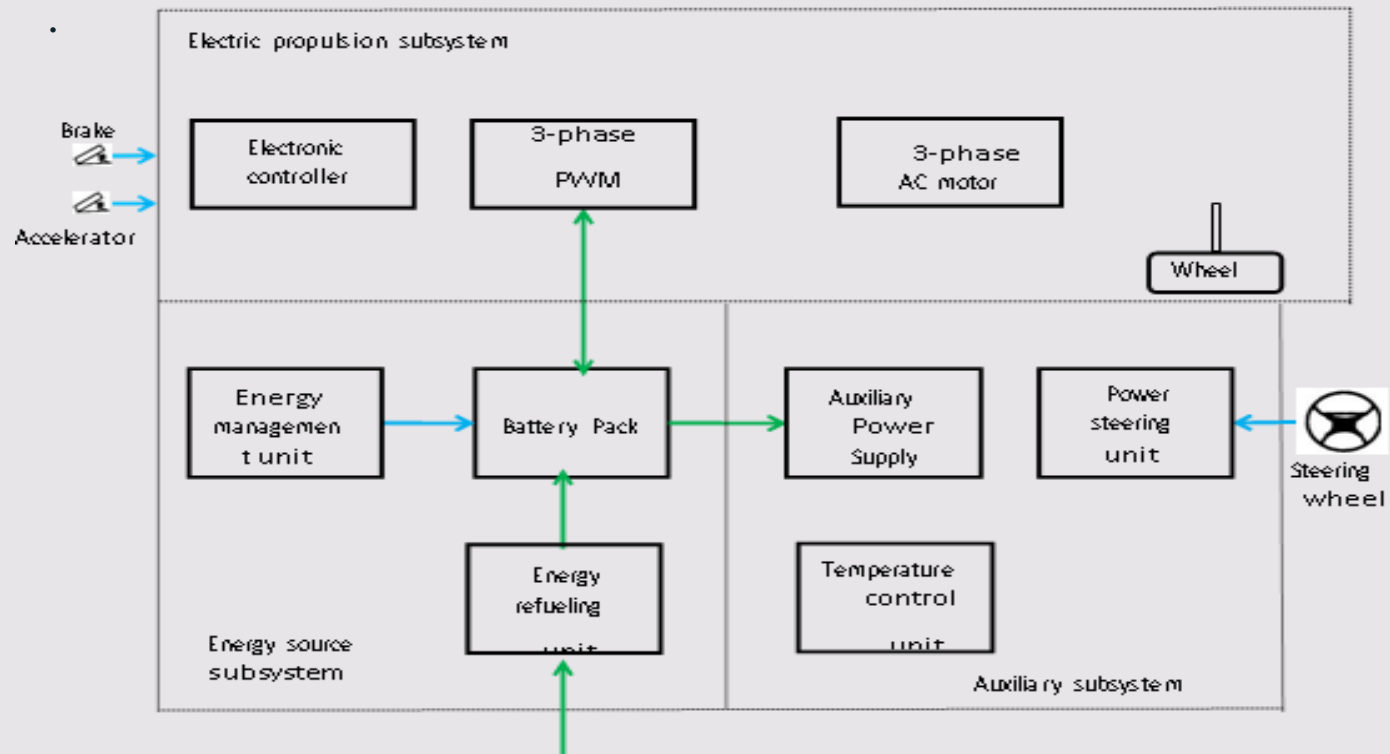



Centurion
UNIVERSITY
Shaping Lives...
Empowering Communities...

Electric Vehicle (EV) Drivetrain Alternatives Based on Drivetrain Configuration

There are many possible EV configurations due the variations in electric propulsion and energy sources. Based on these variations, six alternatives are possible as shown in **Figure 3**. These six alternatives are

- In **Figure 3a** a single EM configuration with gearbox (GB) and a clutch is shown. It consists of an EM, a clutch (C), a gearbox, and a differential (D). The clutch enables the connection or disconnection of power flow from EM to the wheels. The gear consists of a set of gears with different gear ratios. With the use of clutch and gearbox, the driver can shift the gear ratios and hence the torque going to the wheels can be changed. The wheels have high torque low speed in the lower gears and high-speed low torque in the higher gears.

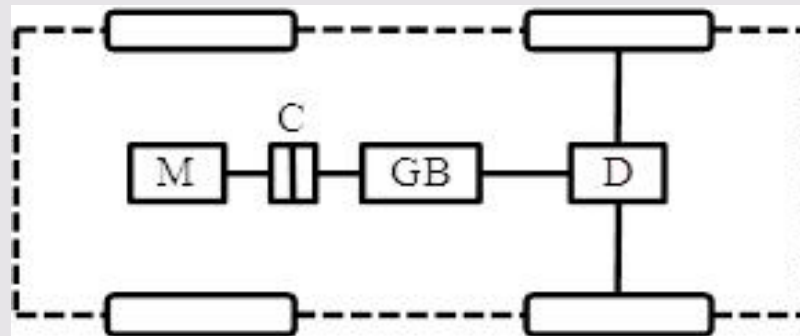

Figure 3a: EV configuration with clutch, gearbox and differential [1]

Cont....



Centurion
UNIVERSITY
*Shaping Lives...
Empowering Communities...*

- In **Figure 3b** a single EM configuration without the gearbox and the clutch is shown. The advantage of this configuration is that the weight of the transmission is reduced. However, this configuration demands a more complex control of the EM to provide the necessary torque to the wheels.

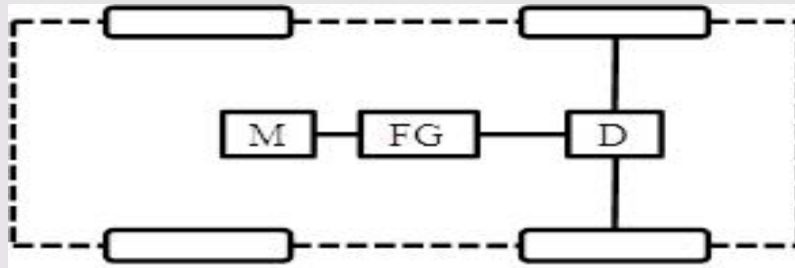

Figure 3b: EV configuration without clutch and gearbox

- Figure 3c** shows a configuration of EV using one EM. It is a transverse front EM front wheel drive configuration. It has a fixed gearing and differential and they are integrated into a single assembly



Figure 3c: EV configuration with clutch, gearbox and differential

Cont....



Centurion
UNIVERSITY
*Shaping Lives...
Empowering Communities...*

In **Figure 3d** a dual motor configuration is shown. In this configuration the differential action of an EV when cornering can be electronically provided by two electric motors.

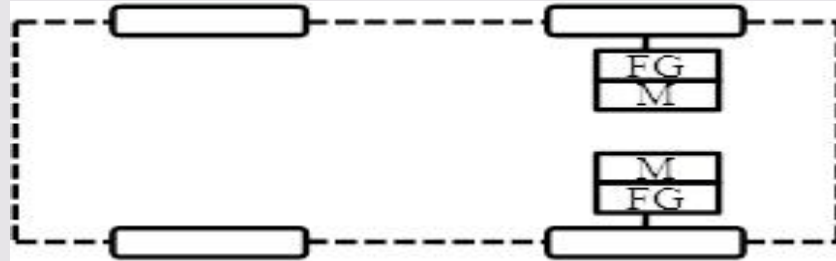

Figure 3d: EV configuration with two EM

- **Figure 3e** • In order to shorten the mechanical transmission path from the EM to the driving wheel, the EM can be placed inside a wheel. This configuration is called in-wheel drive. **Figure 3e** shows this configuration in which fixed planetary gearing is employed to reduce the motor speed to the desired wheel speed.

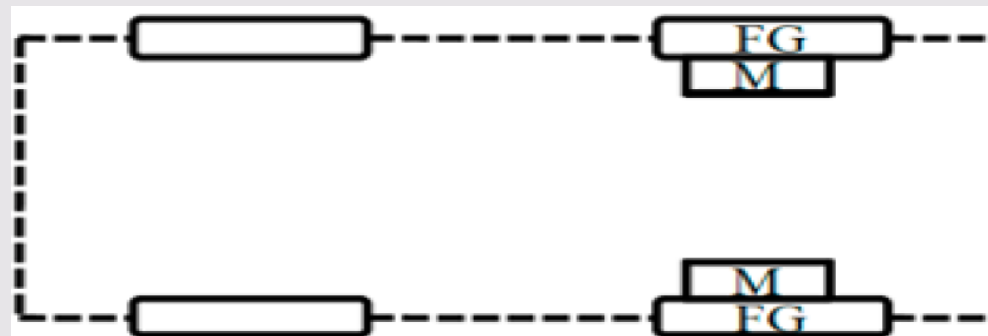

Figure 3e: EV configuration with in wheel motor and mechanical gear

Cont....



Centurion
UNIVERSITY

*Shaping Lives...
Empowering Communities...*

- In Figure 3f an EV configuration without any mechanical gearing is shown. By fully abandoning any mechanical gearing, the in-wheel drive can be realized by installing a low speed outer-rotor electric motor inside a wheel.

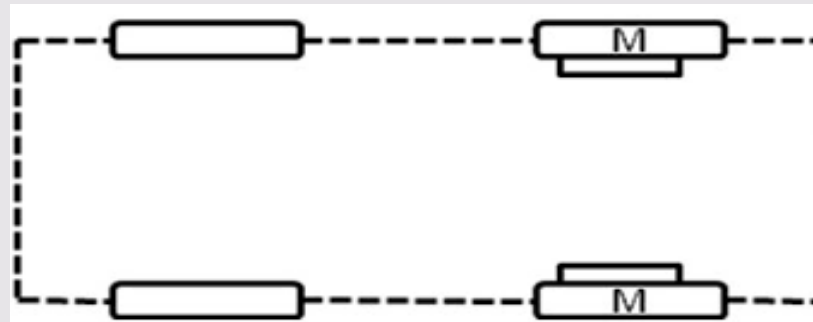

Figure 3f: EV configuration with two EM

C: Clutch
D: Differential
FG: Fixed gearing

GB: Gearbox
EM: Electric motor



Centurion
UNIVERSITY

Shaping Lives...
Empowering Communities...

Electric Vehicle (EV) Drivetrain Alternatives Based on Power Source Configuration

Besides the variations in electric propulsion, there are other EV configurations due to variations in energy sources. There are five configurations possible and they are:

- **Configuration 1:** It is a simple battery powered configuration, **Figure 4a**. The battery may be distributed around the vehicle, packed together at the vehicle back or located beneath the vehicle chassis. The battery in this case should have reasonable specific energy and specific power and should be able to accept regenerative energy during braking. In case of EVs, the battery should have both high specific energy and specific power because high specific energy governs the driving range while the high power density governs the acceleration rate and hill climbing capability.

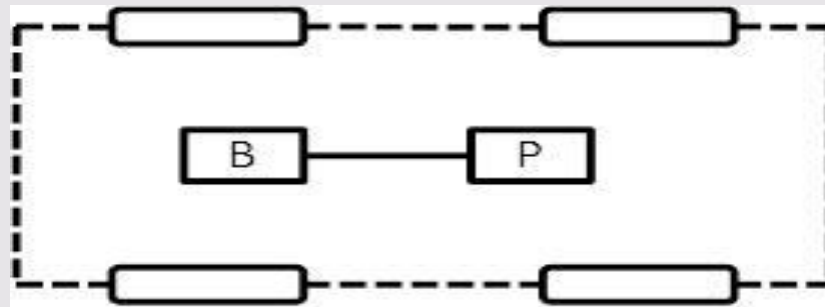

Figure 4a: EV configuration with battery source



Centurion
UNIVERSITY

Shaping Lives...
Empowering Communities...

Cont.....

- **Configuration 2:** Instead of two batteries, this design uses two different batteries, Figure 4b. One battery is optimized for high specific energy and the other for high specific power.

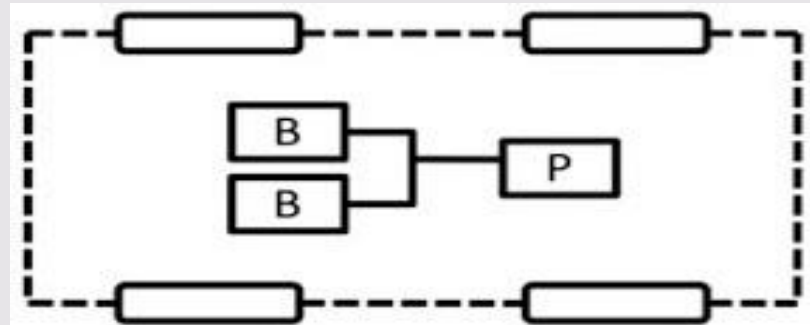

Figure 4b: EV configuration with two battery sources

- **Configuration 3:** In this arrangement fuel cell is used, **Figure 4c**. The battery is an energy storage device, whereas the fuel cell is an energy generation device. The operation principle of fuel cells is a reverse process of electrolysis. In reverse and electrolysis, hydrogen and oxygen gases combine to form electricity and water. The hydrogen gas used by the fuel cell can be stored in an on-board tank whereas oxygen gas is extracted from air. Since fuel cell can offer high specific energy but cannot accept regenerative energy, it is preferable to combine it with battery with high specific power and high-energy receptivity



Centurion
UNIVERSITY
*Shaping Lives...
Empowering Communities...*

Cont.....

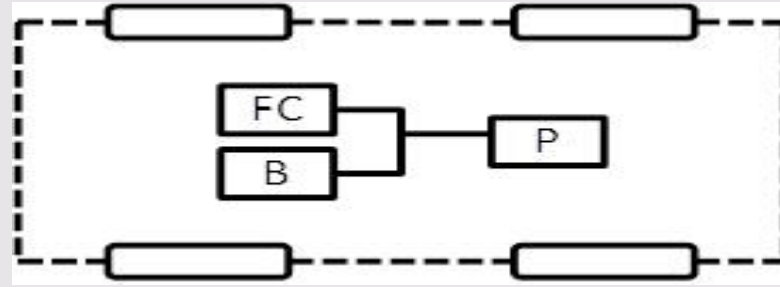

Figure 4c: EV configuration with battery and fuel cell sources

- **Configuration 4:** Rather than storing it as a compressed gas, a liquid or a metal hydride, hydrogen can be generated on-board using liquid fuels such as methanol, **Figure 4d**. In this case a mini reformer is installed in the EV to produce necessary hydrogen gas for the fuel cell.

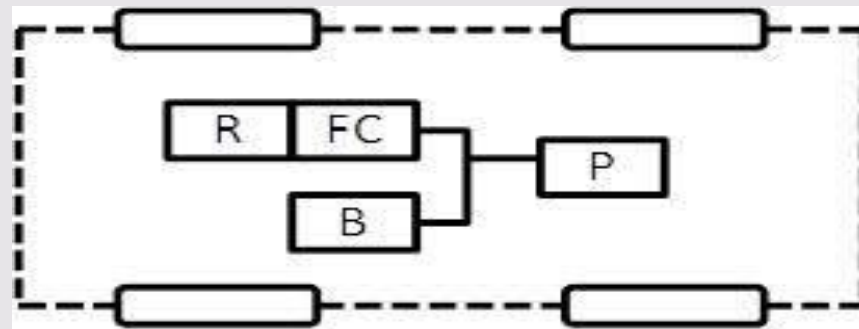

Figure 4d: EV configuration with multiple energy sources



Centurion
UNIVERSITY

Shaping Lives...
Empowering Communities...

Cont.....

- **Configuration 5:** In fuel cell and battery combination, the battery is selected to provide high specific power and high-energy receptivity. In this configuration a battery and supercapacitor combination is used as an energy source, **Figure 4e**. The battery used in this configuration is a high energy density device whereas the supercapacitor provides high specific power and energy receptivity. Usually, the supercapacitors are of relatively low voltage levels, an additional dc-dc power converter is needed to interface between the battery and capacitor terminals.

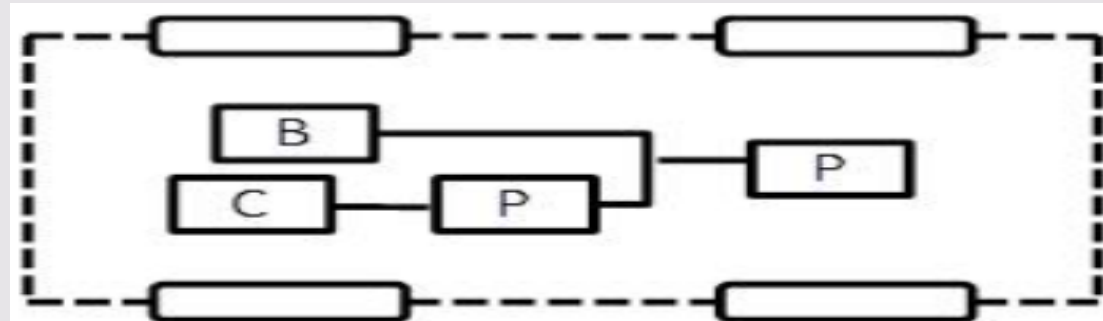

Figure 4e: EV configuration with battery and capacitors sources

B: Battery
C: Capacitor
FC: Fuel cell

FW: Flywheel
P: Power converter
R: Reformer



Centurion
UNIVERSITY
*Shaping Lives...
Empowering Communities...*

Single and Multi-motor Drives

A differential is a standard component for conventional vehicles. When a vehicle is rounding a curved road, the outer wheel needs to travel on a larger radius than the inner wheel. Thus, the differential adjusts the relative speeds of the wheels. If relative speeds of the wheels are not adjusted, then the wheels will slip and result in tire wear, steering difficulties and poor road holding. In case of EVs, it is possible to dispense the mechanical differential by using two or even four EMs. With the use of multiple EMs, each wheel can be coupled to an EM and this will enable independent control of speed of each wheel in such a way that the differential action can be electronically achieved. In **Figure 5**, a typical dual motor drive with an electronic differential is shown.

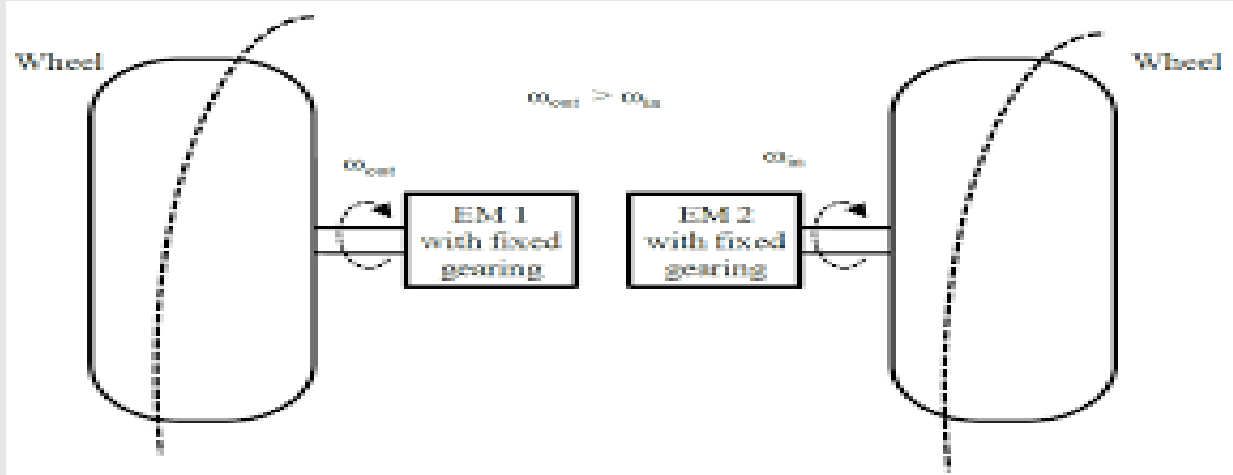

Figure 5: Differential action



Centurion
UNIVERSITY

Shaping Lives...
Empowering Communities...

In Wheel Drives

By placing an electric motor inside the wheel, the in wheel motor has the advantage that the mechanical transmission path between the electric motor and the wheel can be minimized. Two possible configurations for in wheel drives are:

- When a high-speed inner-rotor motor is used (**Figure 6a**) then a fixed speed-reduction gear becomes necessary to attain a realistic wheel speed. In general, speed reduction is achieved using a planetary gear set. This planetary gear is mounted between the motor shaft and the wheel rim. Usually this motor is designed to operate up to 1000 rpm so as to give high power density.
- In case outer rotor motor is used (**Figure 6b**), then the transmission can be totally removed and the outer rotor acts as the wheel rim and the motor speed is equivalent to the wheel speed and no gears are required.

The tradeoffs of the high-speed inner rotor motor are:

- It has the advantage of smaller size, lighter weight and lower cost
- Needs additional planetary gearset

The tradeoffs of outer-rotor motor are

- Low speed and hence does not need additional gears
- The drawbacks are larger size, weight and cost because of the low speed design.



Cont....

Centurion
UNIVERSITY

Shaping Lives...
Empowering Commu...

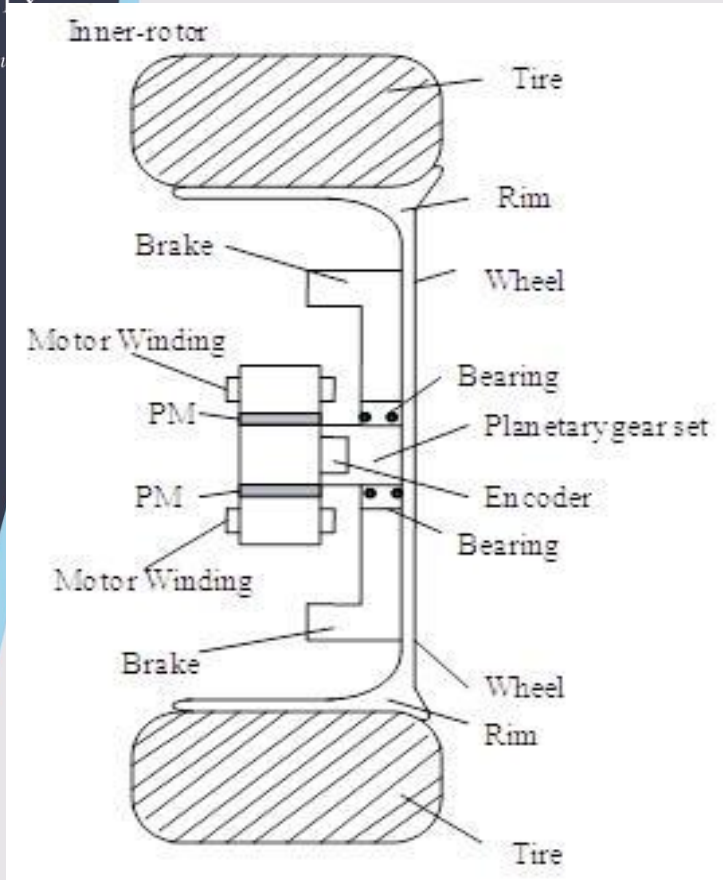

Figure 6a: Inner rotor *In Wheel* drive

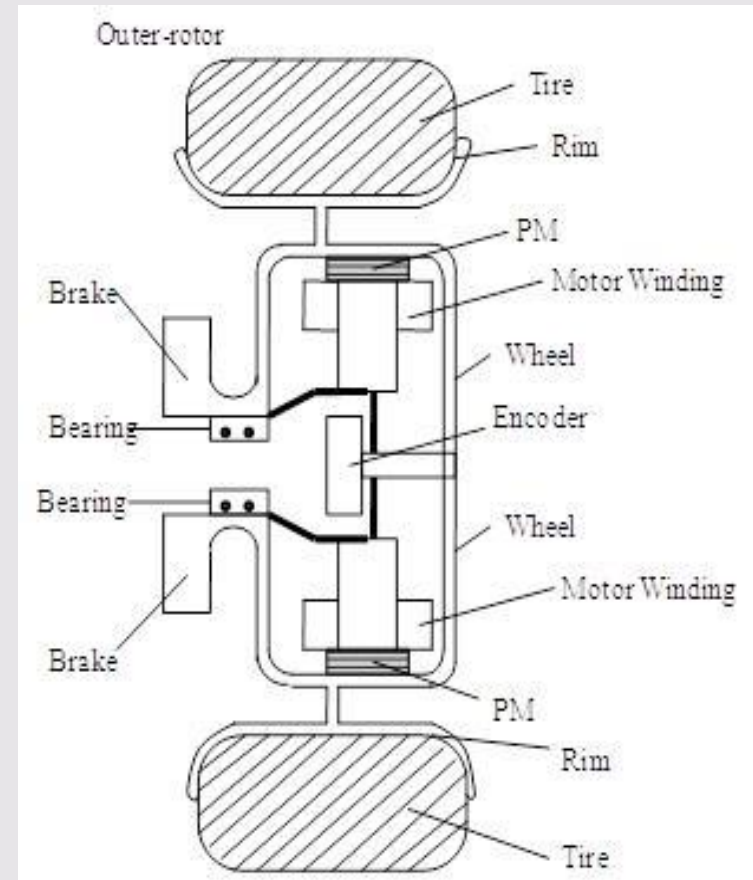

Figure 6b: Outer rotor *In Wheel* drive

Cont....



Centurion
UNIVERSITY

*Shaping Lives...
Empowering Communities...*

Considerations of EMs used in EVs

The requirements of EMs used in EVs are:

- Frequent start/stop
- High rate of acceleration and deceleration
- High torque low speed hill climbing
- Low torque cruising
- Very wide speed range of operation

The EMs for EVs are unique and their major differences with respect to industrial motors in load requirement, performance specification and operating environment are as follows:

- EV motors need to produce the maximum torque that is four to five times of the rated torque for acceleration and hill climbing, while industrial motors generally offer the maximum torque that is twice of the rated torque for overload operation
- EV motors need to achieve four to five times the base speed for highway cruising, while industrial motors generally achieve up to twice the base speed for constant power operation
- EV motors require high power density as well as good efficiency map (high efficiency over wide speed and torque ranges), while industrial motors are generally optimized to give high efficiency at a rated point.
- EV motors need to be installed in mobile vehicles with harsh operating conditions such as high temperature, bad weather and frequent vibration, while industrial motors are generally located in fixed places.