



Centurion
UNIVERSITY

Shaping Lives...
Empowering Communities...

S I Engine Ignition System



Centurion
UNIVERSITY

Step by Step...
Empowering Communities...

Basically Convectional S I Engine Ignition systems are of 2 types :

(a) Battery or Coil Ignition System

Battery ignition system was generally used in 4-wheelers. But now-a-days it is more commonly used in 2-wheelers also (i.e. Button start, 2-wheelers like Pulsar, Kinetic Honda; Honda-Activa, Scooty, Fiero, etc.). In this case 6 V or 12 V batteries will supply necessary current in the primary winding.



Centurion
UNIVERSITY
Shaping Lives...
Empowering Communities...

(b) Magneto Ignition System.

Magneto ignition system is mainly used in 2-wheelers, kick start engines. (Example, Bajaj Scooters, Boxer, Victor, Splendor, Passion, etc.). In this case magneto will produce and supply current to the primary winding. So in magneto ignition system magneto replaces the battery.



Centurion
UNIVERSITY
Shaping Lives...
Empowering Communities...

Battery or Coil Ignition System

It mainly consists of a 6 or 12 volt battery, ammeter, ignition switch, auto-transformer (step up transformer), contact breaker, capacitor, distributor rotor, distributor contact points, spark plugs, etc.



Centurion

Battery or Coil Ignition System

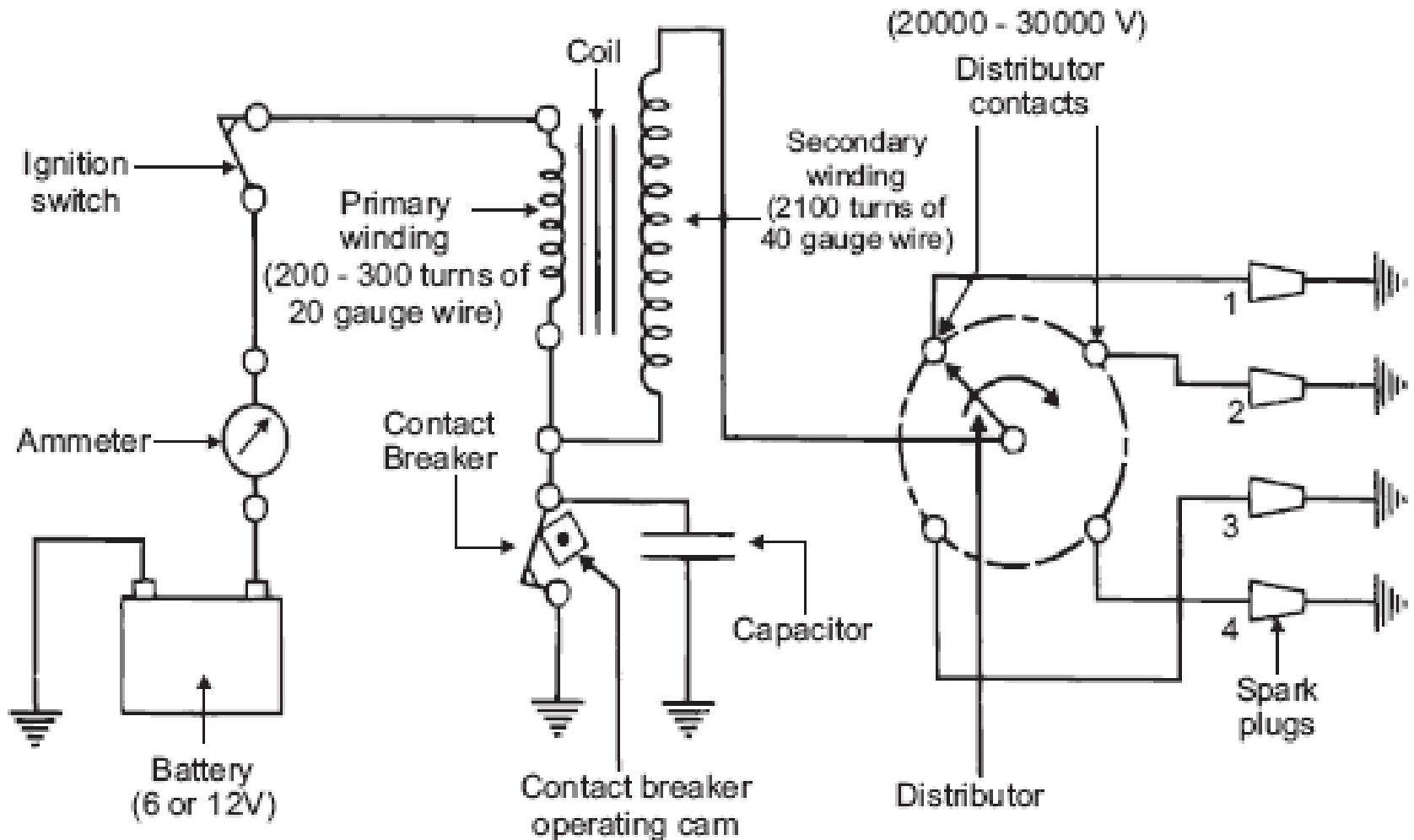



Centurion
UNIVERSITY
*Shaping Lives...
Empowering Communities.*

The ignition system is divided into 2-circuits :

Primary Circuit :

It consists of 6 or 12 V battery, ammeter, ignition switch, primary winding it has 200-300 turns of 20 SWG (Sharps Wire Gauge) gauge wire, contact breaker, capacitor.

(ii) Secondary Circuit :

It consists of secondary winding. Secondary winding consists of about 21000 turns of 40 (S WG) gauge wire. Bottom end of which is connected to bottom end of primary and top end of secondary winding is connected to centre of distributor rotor. Distributor rotors rotate and make contacts with contact points and are connected to spark plugs which are fitted in cylinder heads (engine earth).



Centurion
UNIVERSITY
Shaping Lives...
Empowering Communities...

How it works?

- When the ignition switch is closed and engine is cranked, as soon as the contact breaker closes, a low voltage current will flow through the primary winding.
- The contact breaker cam opens and closes the circuit 4-times (for 4 cylinders) in one revolution.
- When the contact breaker opens the contact, the magnetic field begins to collapse.
- Because of this collapsing magnetic field, current will be induced in the secondary winding.
- Because of more turns (@ 21000 turns) of secondary, voltage goes upto 28000-30000 volts.



Centurion
UNIVERSITY

*Shaping Lives...
Empowering Communities...*

How it works? (Continued)

This high voltage current is brought to centre of the distributor rotor.

- Distributor rotor rotates and supplies this high voltage current to proper spark plug depending upon the engine firing order.
- When the high voltage current jumps the spark plug gap, it produces the spark and the charge is ignited- combustion starts-products of combustion expand and produce power.

Function of Capacitor



Centurion
UNIVERSITY
Shaping Lives...
Empowering Communities

(a) The Function of the capacitor is to reduce arcing at the contact breaker (CB) points. Also when the CB opens the magnetic field in the primary winding begins to collapse.

(b) When the magnetic field is collapsing capacitor gets fully charged and then it starts discharging and helps in building up of voltage in secondary winding.

Function of Contact Breaker

Contact breaker cam and distributor rotor are mounted on the same shaft.

- In 2-stroke cycle engines these are motored at the same engine speed
- In 4-stroke cycle engines they are motored at half the engine speed.



Magneto Ignition System

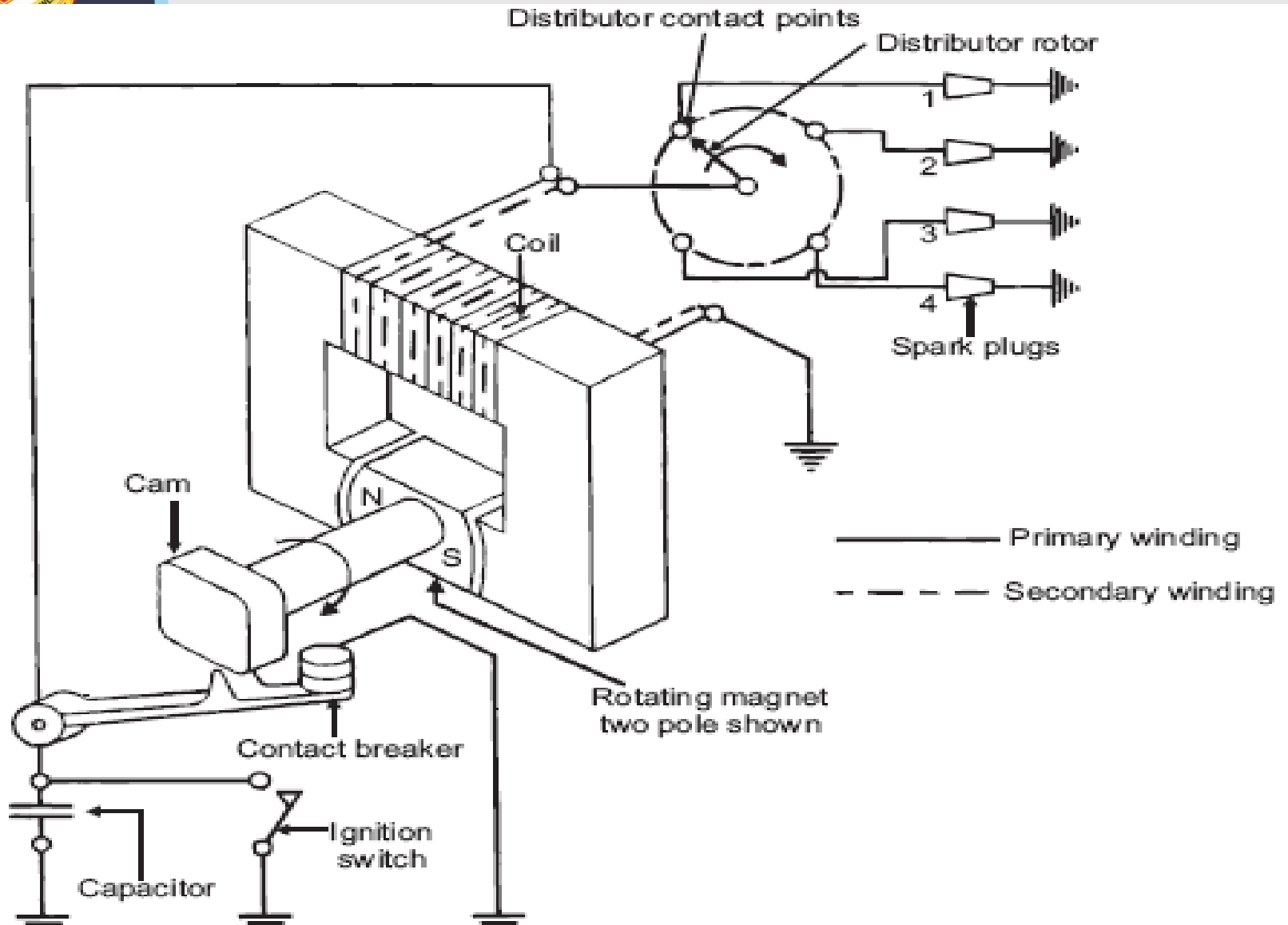



Centurion
UNIVERSITY
Shaping Lives...
Empowering Communities...

How it works?

In this case magneto will produce and supply the required current to the primary winding.

In this case as shown, we can have rotating magneto with fixed coil or rotating coil with fixed magneto for producing and supplying current to primary, remaining arrangement is same as that of a battery ignition system.



COMPARISION

Battery Ignition	Magneto Ignition
Battery is a must.	No battery needed.
Battery supplies current in primary circuit.	Magneto produces the required current for primary circuit.
A good spark is available at low speed also.	During starting the quality of spark is poor due to slow speed.
Occupies more space.	Very much compact.
Recharging is a must in case battery gets discharged.	No such arrangement required.
Mostly employed in car and bus for which it is required to crank the engine.	Used on motorcycles, scooters, etc.
Battery maintenance is required.	No battery maintenance problems.



DRAWBACKS OF CONVENTIONAL IGNITION SYSTEMS

Centurion
UNIVERSITY
*Shaping Lives
Empowering Communities...*

Because of arcing, pitting of contact breaker point and which will lead to regular maintenance problems.

- **Poor starting** : After few thousands of kilometers of running, the timing becomes inaccurate, which results into poor starting (Starting trouble).
- **At very high engine speed**, performance is poor because of inertia effects of the moving parts in the system.
- **Some times it is not possible to produce spark properly in fouled spark plugs.**

ADVANTAGES OF ELECTRONIC IGNITION SYSTEM



Centurion
UNIVERSITY
Shaping Lives...
Empowering Communities...

- Moving parts are absent-so no maintenance.
- Contact breaker points are absent-so no arcing.
- Spark plug life increases by 50% and they can be used for about 60000 km without any problem.
- Better combustion in combustion chamber, about 90-95% of air fuel mixture is burnt compared with 70-75% with conventional ignition system.
- More power output.
- More fuel efficiency.



Centurion
UNIVERSITY

Shaping Lives...
Empowering Communities...

TYPES OF ELECTRONIC IGNITION SYSTEM

Capacitance Discharge Ignition
system

Transistorized system

Piezo-electric Ignition system

The Texaco Ignition system



Capacitance Discharge Ignition System

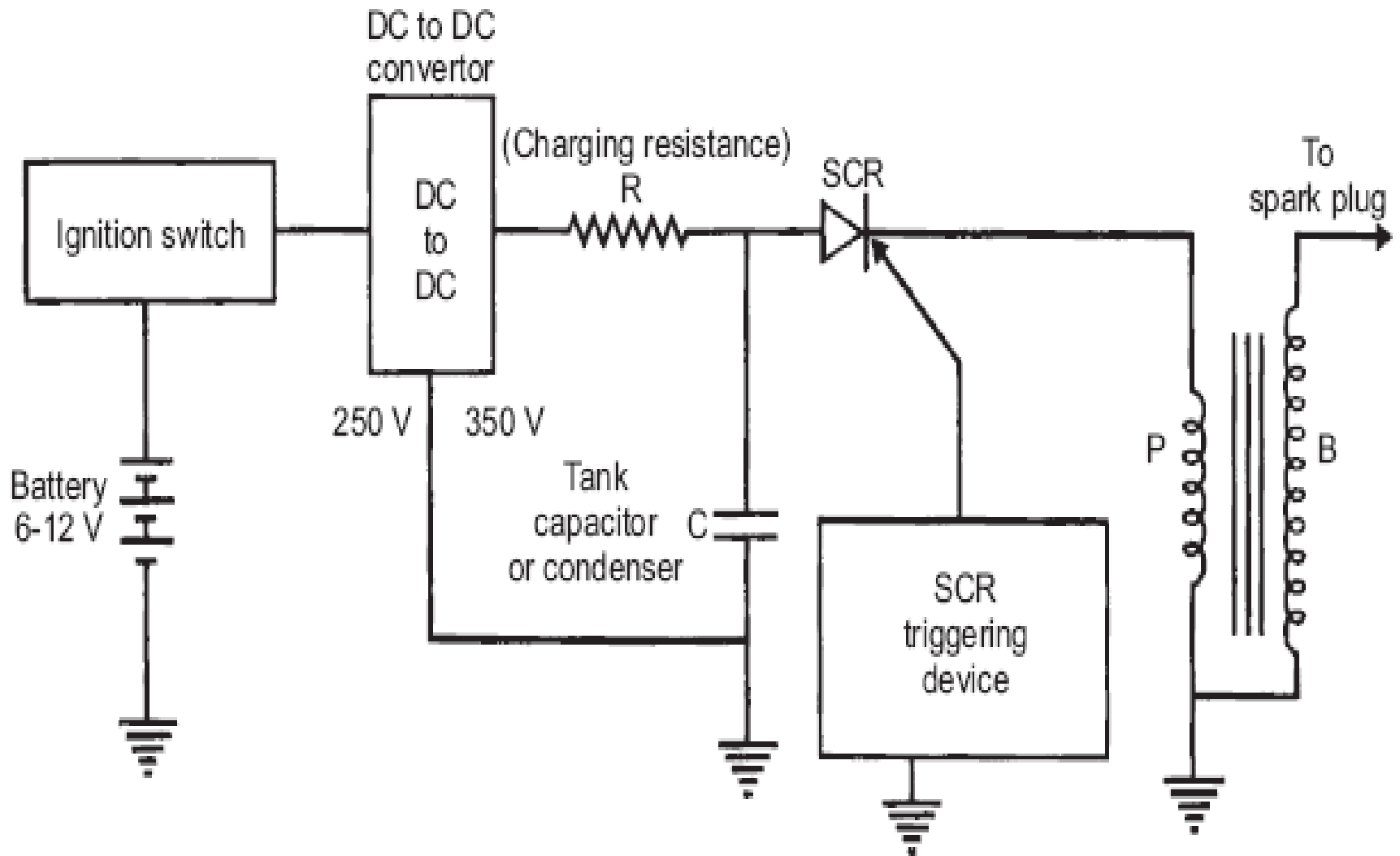



Centurion
UNIVERSITY

*Shaping Lives...
Empowering Communities...*

How it works?

It mainly consists of 6-12 V battery, ignition switch, DC to DC converter, charging resistance, tank capacitor, Silicon Controlled Rectifier (SCR), SCR-triggering device, step up transformer, spark plugs.

- A 6-12 volt battery is connected to DC to DC converter i.e. power circuit through the ignition switch, which is designed to give or increase the voltage to 250-350 volts. This high voltage is used to charge the tank capacitor (or condenser) to this voltage through the charging resistance.
- The charging resistance is also so designed that it controls the required current in the SCR.



Centurion
UNIVERSITY
Shaping Lives.
Empowering Communities.

How it works? (Contd.)

Depending upon the engine firing order, whenever the SCR triggering device, sends a pulse, then the current flowing through the primary winding is stopped and the magnetic field begins to collapse.

This collapsing magnetic field will induce or step up high voltage current in the secondary, which while jumping the spark plug gap produces the spark, and the charge of air fuel mixture is ignited.



Centurion
UNIVERSITY

*Shaping Lives...
Empowering Communities...*

Transistorized Assisted Contact (TAC) Ignition System

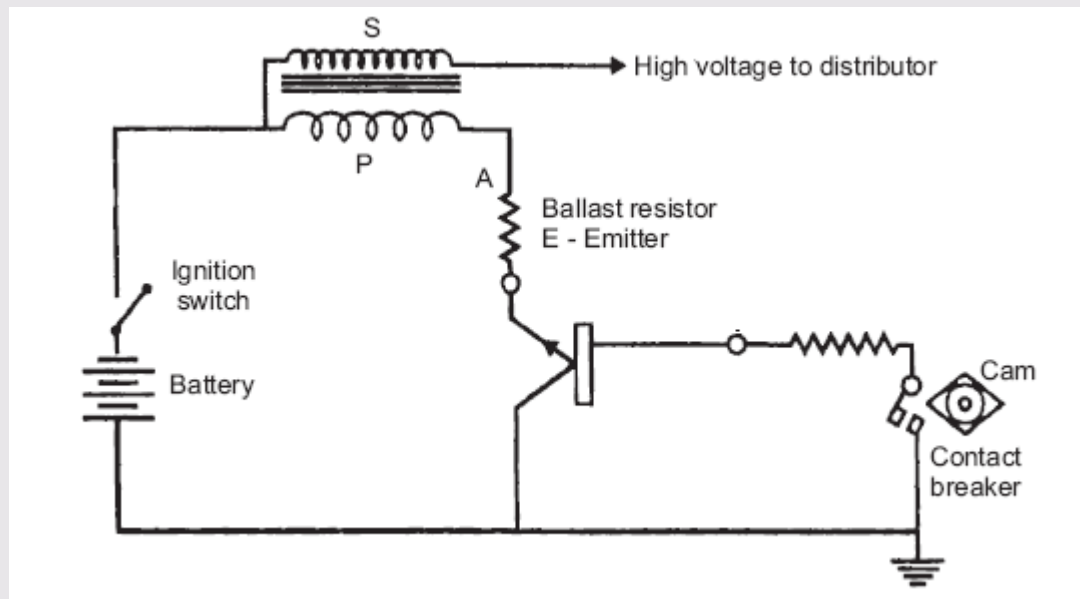



Centurion
UNIVERSITY
Shaping Lives...
Empowering Communities...

Advantages of TAC Ignition System

The low breaker-current ensures longer life.

The smaller gap and lighter point assembly increase dwell time minimize contact bouncing and improve repeatability of secondary voltage.

The low primary inductance reduces primary inductance reduces primary current drop-off at high speeds.



Centurion
UNIVERSITY

Shaping Lives...
Empowering Communities...

Disadvantages of TAC Ignition System

As in the conventional system, mechanical breaker points are necessary for timing the spark.

The cost of the ignition system is increased.

The voltage rise-time at the spark plug is about the same as before



Centurion
UNIVERSITY
Shaping Lives...
Empowering Communities...

Piezo-electric Ignition System

The development of synthetic piezo-electric materials producing about 22 kV by mechanical loading of a small crystal resulted in some ignition systems for single cylinder engines.

But due to difficulties of high mechanical loading need of the order of 500 kg timely control and ability to produce sufficient voltage, these systems have not been able to come up.



Centurion
UNIVERSITY
Shaping Lives...
Empowering Communities...

The Texaco Ignition System

Due to the increased emphasis on exhaust emission control, there has been a sudden interest in exhaust gas recirculation systems and lean fuel-air mixtures.

- To avoid the problems of burning of lean mixtures, the Texaco Ignition system has been developed. It provides a spark of controlled duration which means that the spark duration in crank angle degrees can be made constant at all engine speeds.
- It is a AC system. This system consists of three basic units, a power unit, a control unit and a distributor sensor.
- This system can give stable ignition up to A/F ratios as high as 24 : 1.



Centurion
UNIVERSITY
Shaping Lives...
Empowering Communities...

FIRING ORDER

The order or sequence in which the firing takes place, in different cylinders of a multi-cylinder engine is called Firing Order.

In case of SI engines the distributor connects the spark plugs of different cylinders according to Engine Firing Order.

A proper firing order reduces engine vibrations.

Maintains engine balancing.

Secures an even flow of power.



Centurion
UNIVERSITY
Shining Lives
Empowering Communities...

PROBABLE FIRING ORDERS FOR DIFFERENT ENGINES

3 cylinder = 1-3-2

4 cylinder engine (inline) = 1-3-4-2, 1-2-4-3

4 cylinder horizontal opposed engine = 1-4-3-2, (Volkswagen engine)

6-cylinder in line engine (Crank in 3 pairs) =

1-5-3-6-2-4, 1-4-2-6-3-5. 1-3-2-6-4-5, 1-2-4-6-5-3

8 cylinder in line engine

1-6-2-5-8-3-7-4, 1-4-7-3-8-5-2-6

8 cylinder V type 1-

5-4-8-6-3-7-2, 1-5-4-2-6-3-7-8, 1-6-2-5-8-3-7-4, 1-8-4-3-6-5-7-2

Note: Cylinder 1 is taken from front of inline and front right side in V engines.



Centurion
UNIVERSITY
Shaping Lives...
Empowering Communities...

IGNITION ADVANCE

When the charge is ignited, it will take some time to come to the required rate of burning.

The purpose of spark advance mechanism is to assure that under every condition of engine operation, ignition takes place at the most favorable instant in time i.e. most favorable from a standpoint of engine power, fuel economy and minimum exhaust dilution.

By means of these mechanisms the advance angle is accurately set so that ignition occurs before TDC point of the piston.



Centrifugal Advance Mechanism

Centrifugal
Sh
En

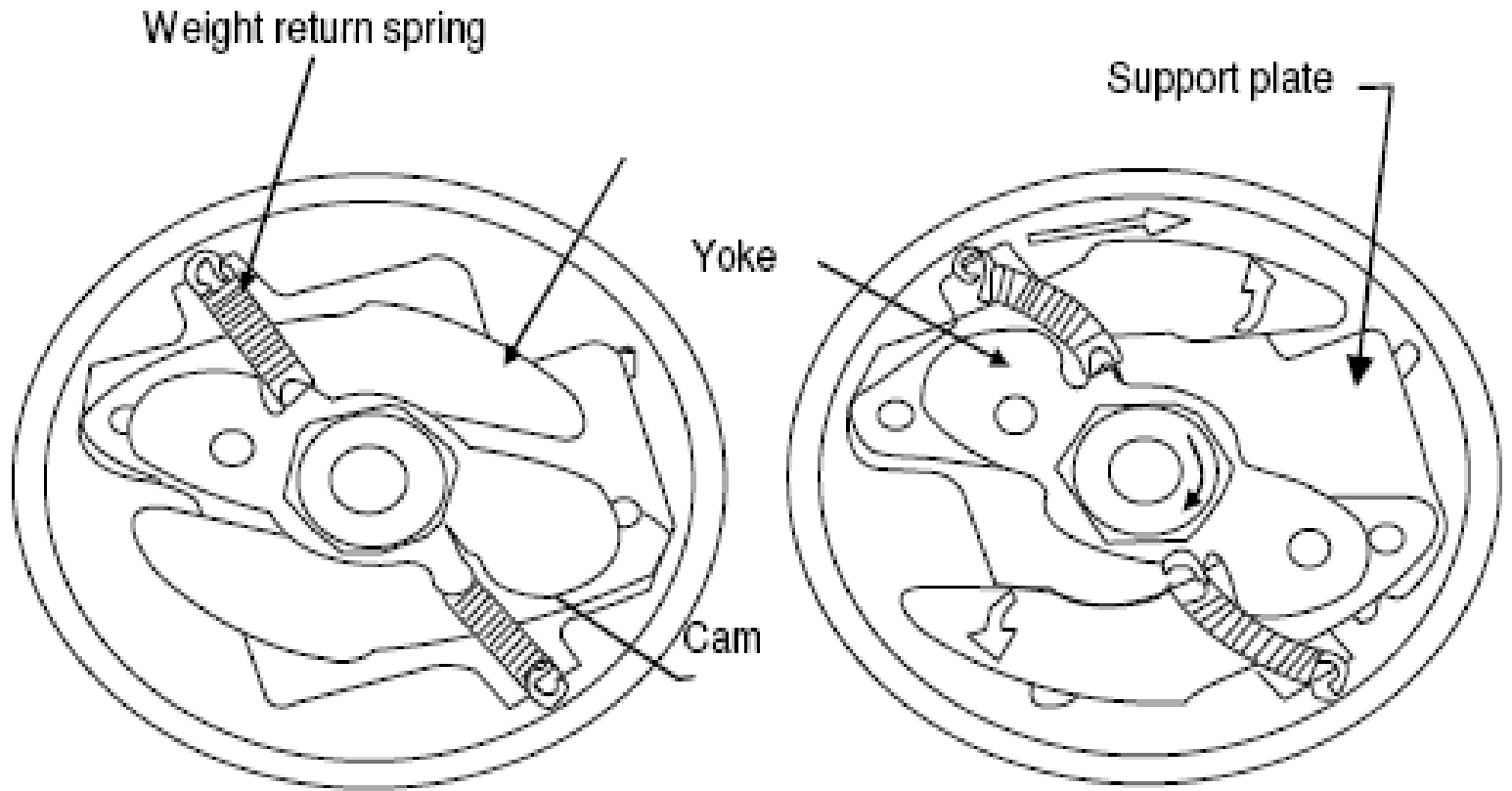



Centurion
UNIVERSITY
Shaping Lives.
Empowering Communities.

How it works?

- The cam is mounted, movably, on the distributor shaft so that as the speed increases, the flyweights which are swung farther and farther outward, shaft the cam in the direction of shaft rotation.
- As a result, the cam lobes make contact with the breaker lever rubbing block somewhat earlier, thus shifting the ignition point in the early or advance direction.
- Depending on the speed of the engine, and therefore of the shaft, the weights are swung outward a greater or a lesser distance from the center.
- They are then held in the extended position, in a state of equilibrium corresponding to the shifted timing angle, by a retaining spring which exactly balances the centrifugal force.
- The weights shift the cam either on a rolling contact or sliding contact basis; for this reason we distinguish between the rolling contact type and the sliding contact type of centrifugal advance mechanism.



Centurion
UNIVERSITY

*Shaping Lives...
Empowering Communities...*

Vacuum Advance Mechanism

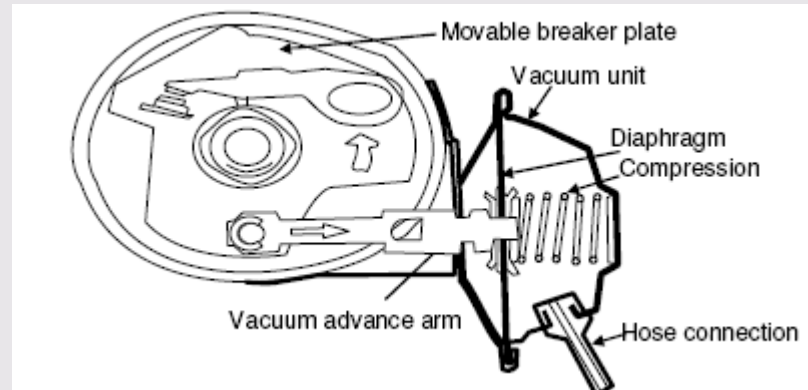



Centurion
UNIVERSITY

Shaping Lives...
Empowering Communities...

How it works?

The diaphragm of a vacuum unit is moved by changes in gas pressure. The position of this diaphragm is determined by the pressure differential at any given moment between the prevailing vacuum and atmospheric pressure.

- The beginning of adjustment is set by the pre-established tension on a compression spring.



Centurion
UNIVERSITY

Shaping Lives...
Empowering Communities...

How it works? (Contd.)

The diaphragm area, the spring force, and the spring rigidity are all selected in accordance with the partial –load advance curve which is to be followed and are all balanced with respect to each other.

The diaphragm movement is transmitted through a vacuum advance arm connected to the movable breaker plate, and this movement shifts the breaker plate an additional amount under partial load condition in a direction opposite to the direction of rotation of the distributor shaft.

Limit stops on the vacuum advance arm in the base of the vacuum unit restrict the range of



Centurion
UNIVERSITY

Shaping Lives...
Empowering Communities...

Thank
s