

ELECTRON TRANSPORT CHAIN (ATP SYNTHASE)





INTRODUCTION

Electron transport chain is the transfer of electrons from NADH and FADH₂ to oxygen via multiple carriers.

The electrons derived from NADH and FADH₂ combine with O₂, and the energy released from these oxidation/reduction reactions is used to derive the synthesis of ATP from ADP.

This transfer of electrons is done by multiple carriers which constitute the **ELECTRON TRANSPORT CHAIN**



MITOCHONDRIA

Matrix. This large internal space contains a highly concentrated mixture of hundreds of enzymes, including those required for the oxidation of pyruvate and fatty acids and for the citric acid cycle. The matrix also contains several identical copies of the mitochondrial DNA genome, special mitochondrial ribosomes, tRNAs, and various enzymes required for expression of the mitochondrial genes.

Inner membrane. The inner membrane (*red*) is folded into numerous cristae, which greatly increases its total surface area. It contains proteins with three types of functions: (1) those that carry out the oxidation reactions of the electron-transport chain, (2) the ATP synthase that makes ATP in the matrix, and (3) transport proteins that allow the passage of metabolites into and out of the matrix. An electrochemical gradient of H^+ , which drives the ATP synthase, is established across this membrane, and so it must be impermeable to ions and most small charged molecules.

Outer membrane. Because it contains a large channel-forming protein (called porin), the outer membrane is permeable to all molecules of 5000 daltons or less. Other proteins in this membrane include enzymes involved in mitochondrial lipid synthesis and enzymes that convert lipid substrates into forms that are subsequently metabolized in the matrix.

Intermembrane space. This space (*white*) contains several enzymes that use the ATP passing out of the matrix to phosphorylate other nucleotides.

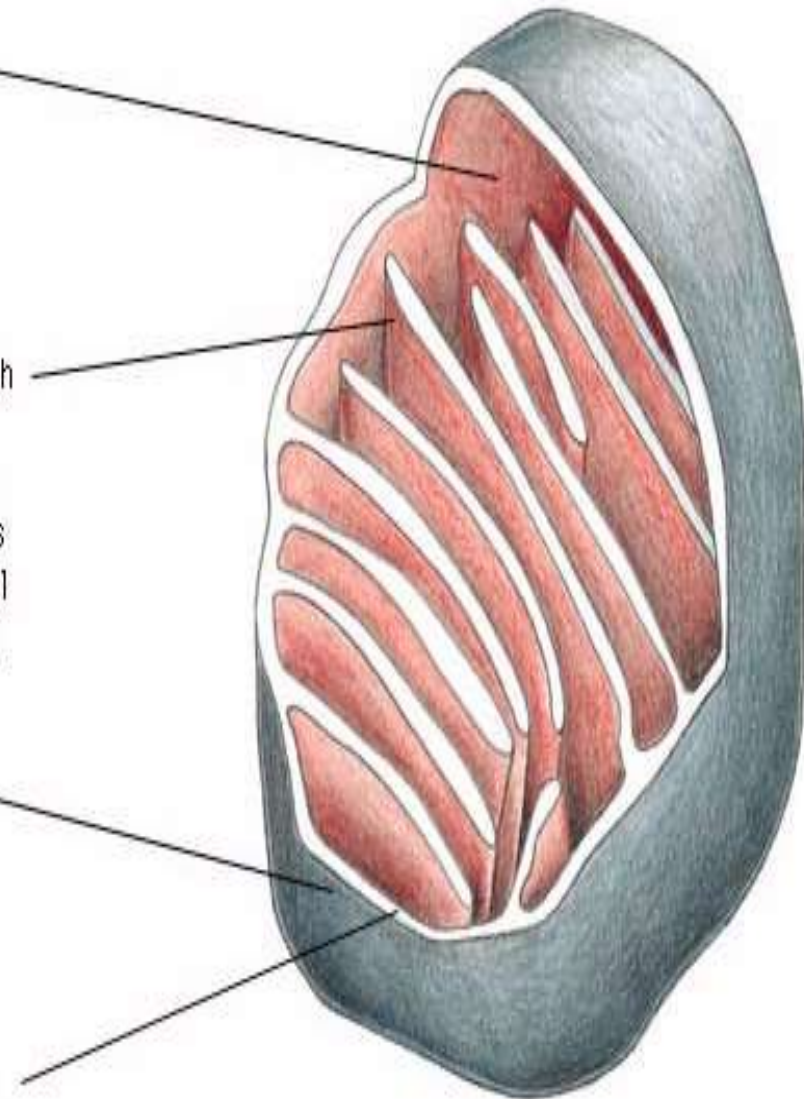



The ETC consists of five separate protein complexes: Complex I , II, III, IV and V.

he complexes I, II, III and IV are involved in transportation of electrons to molecular oxygen.

The complex V is involved in the synthesis of ATP. Each complex consists of certain prosthetic groups which are the 'electron carriers' in that respective complex.

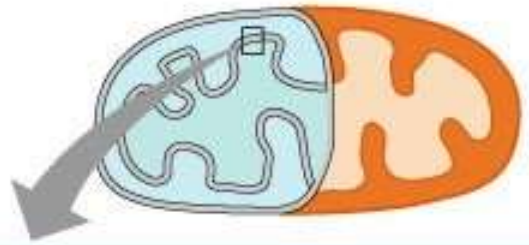
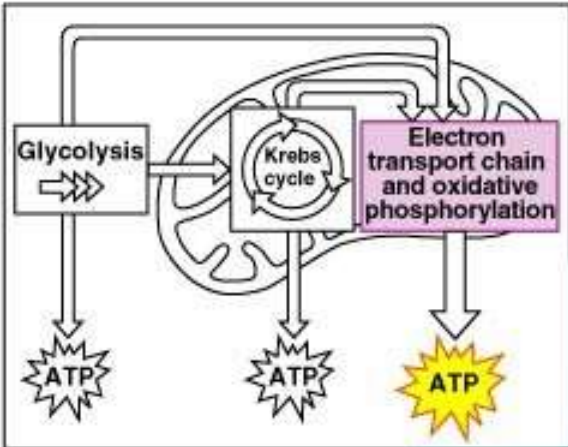

Intermembrane space

Inner mitochondrial membrane

Mitochondrial matrix

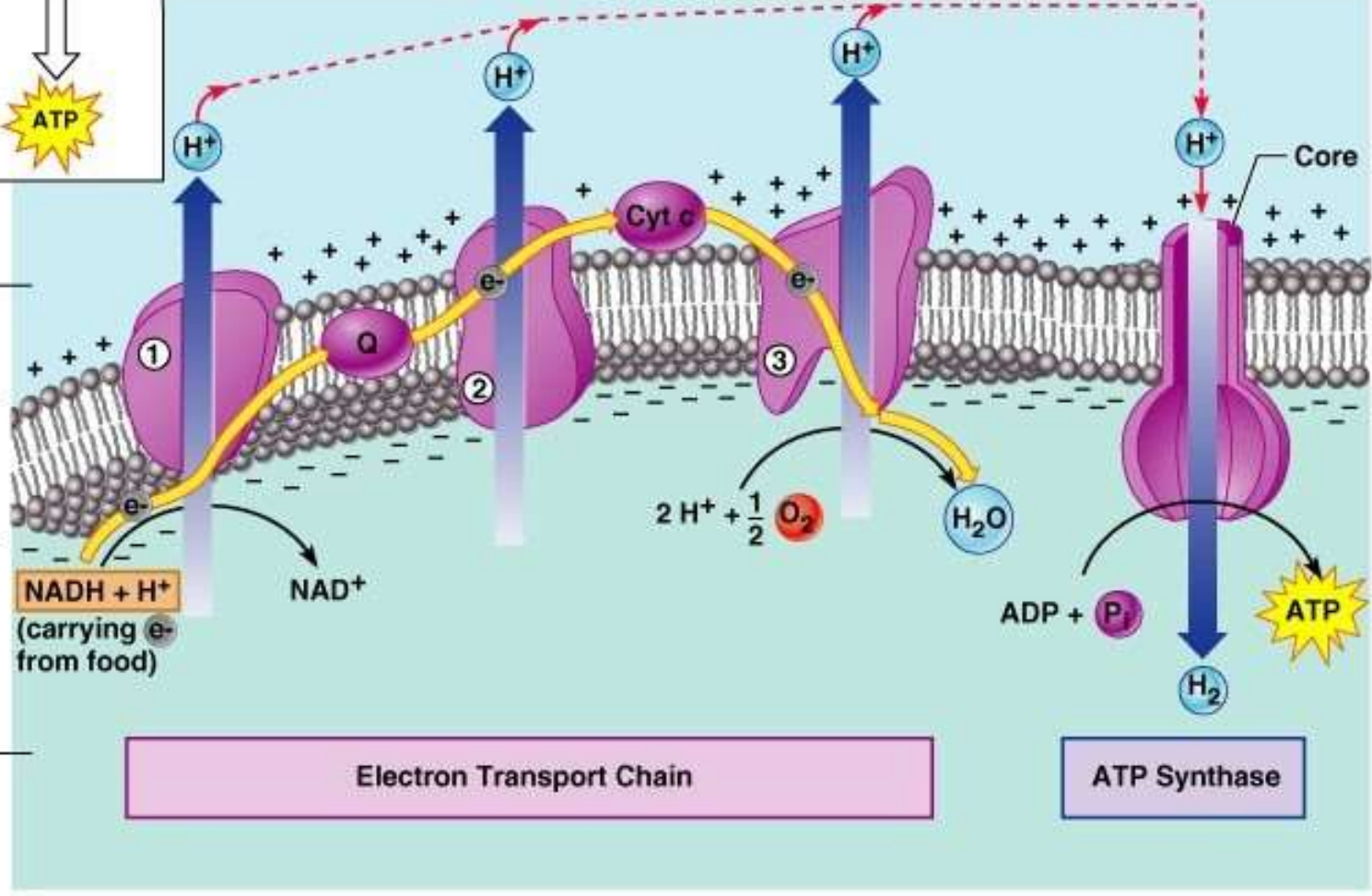



COMPLEX I -NADH Dehydrogenase

- It includes at least 46 proteins, along with prosthetic groups FMN & several Fe-S centres.
- Pumps 4 protons across the mitochondrial membrane .
- Complex I catalyzes oxidation of NADH, with reduction of coenzyme Q. In complex I,
 - electron transport begins when hydrogen ions and electrons are transferred from NADH to complex I.
 - loss of hydrogen from NADH regenerates NAD⁺to oxidize more substrates in oxidative pathways such as the citric acid cycle.
 - hydrogen ions and electrons are transferred to the mobile electron carrier CoQ, forming CoQH₂.
 - CoQH₂ carries electrons from complexes I and II to complex III.

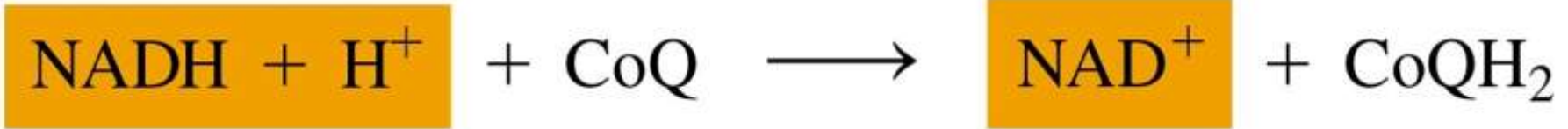
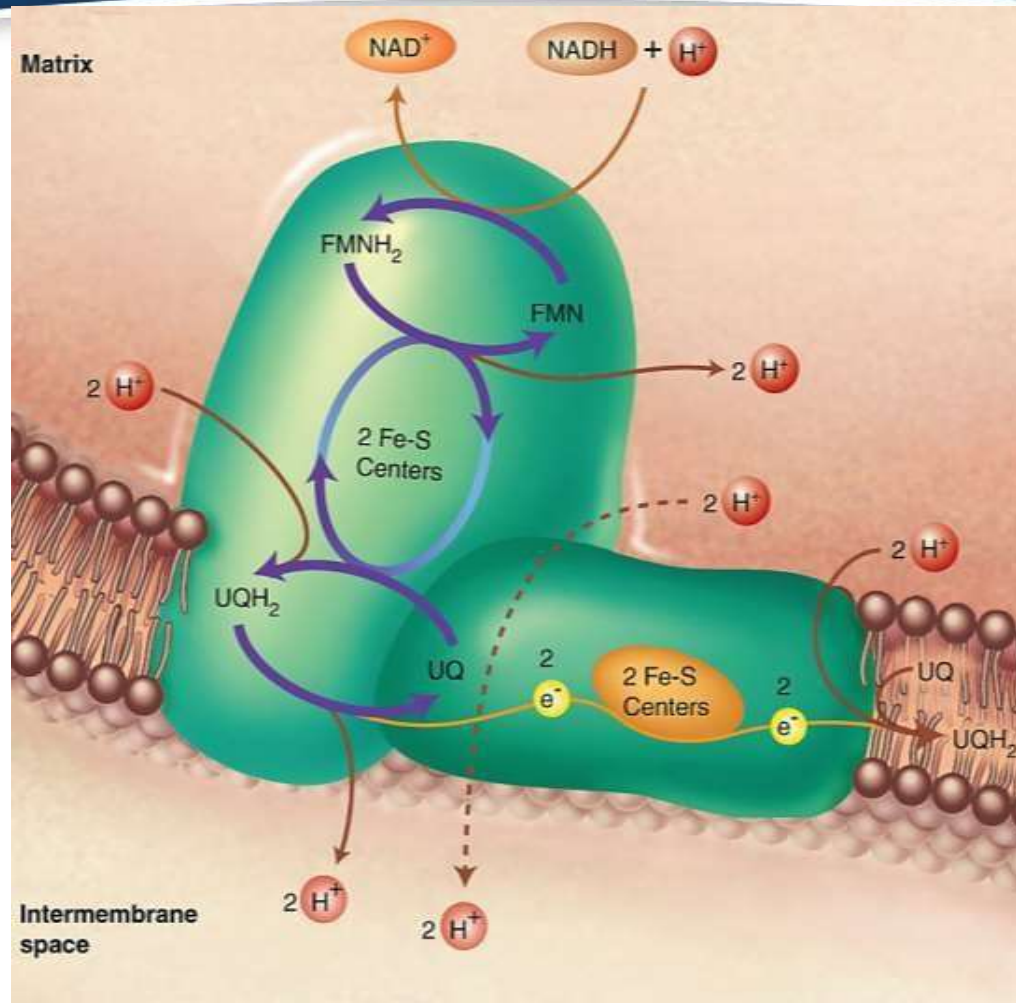



COMPLEX II – Succinate dehydrogenase

Complex II consists of the enzyme *succinate dehydrogenase* from the citric acid cycle.

In complex II,

- CoQ obtains hydrogen and electrons directly from FADH_2 . This produces CoQH_2 and regenerates the oxidized coenzyme FAD, which becomes available to oxidize more substrates.
- To a series of iron-containing proteins called cytochromes.
- electrons are then transferred to two cytochrome *c*, which can move between complexes III and IV.



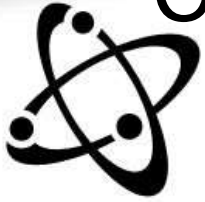

COMPLEX III - Coenzyme Q-dependent cytochrome *c reductase*

Complex III accepts electrons from coenzyme QH₂ that is generated by electron transfer in complexes I & II.

Complex III does transfer protons (2H⁺) into intermembrane space

Each cytochrome consists of a heme group i.e. Iron encaged in a porphyrin ring.

The Iron of heme group is readily convertible to Fe⁺² from Fe⁺³ state

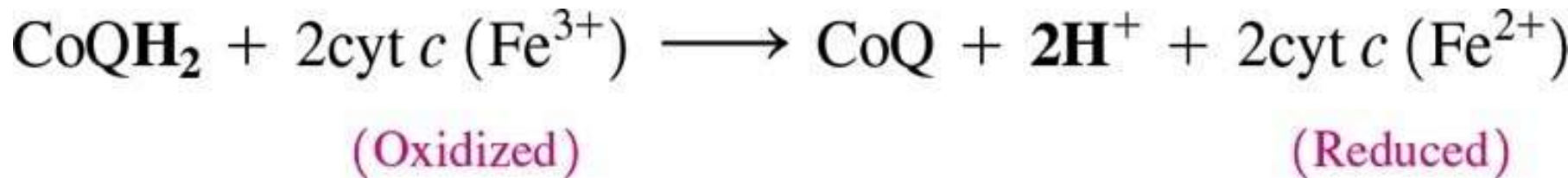



COMPLEX IV - Cytochrome c oxidase

At complex IV,

- four electrons from four cytochrome *c* are passed to other electron carriers.
- electrons combine with hydrogen ions and oxygen (O_2) to form two molecules of water.
- energy is used to pump H^+ from the mitochondrial matrix into the intermembrane space, further increasing the hydrogen ion gradient.





Chemiosmosis

his creates a proton & a charge gradient inside becomes more alkaline and more charged is said to electrochemical gradient

he energy stored in electrochemical gradient is termed “proton motive force” which is used to drive the ATP synthesis by movement of protons down the electrochemical gradient through the ATP synthase.

The process called chemiosmosis

The Chemiosmotic Theory



- . As electrons pass through the ETC, protons are pumped into the intermembrane space, generating proton motive force
- . Protons move back across the membrane through ATP synthase driving ATP formation

COMPLEX V – ATP synthase

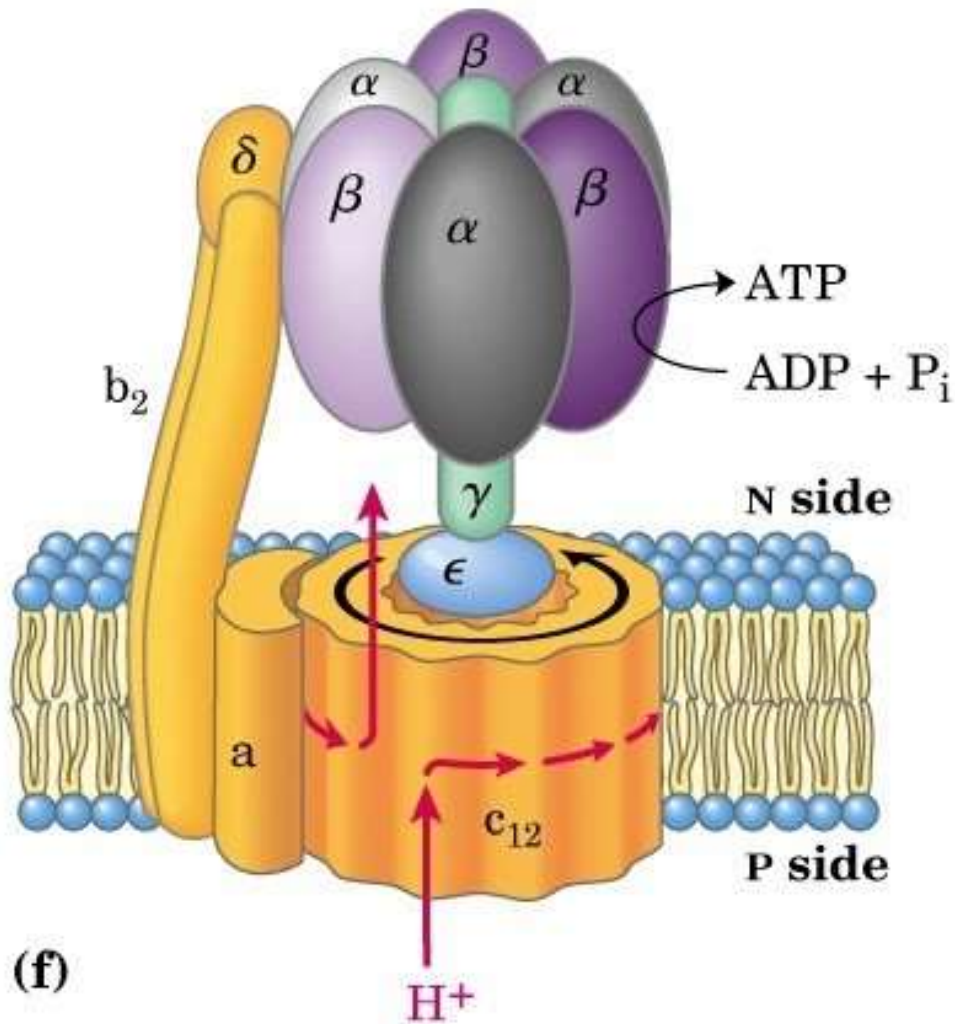



ATP synthase is a reversible coupling device that can convert the energy of the electrochemical proton gradient into chemical bond energy or vice versa. The direction depends on the magnitude of the electrochemical proton gradient.

Mitochondrial ATP synthase consists of two multi-subunit components F₀ and F₁ which are linked by a slender stalk.

F₀ is an electrically driven motor that spans the lipid bilayer forming a channel through which protons can cross the membrane.

F₀ provides a channel for protons.

F₁ harvests the free energy derived from proton movement down the electrochemical gradient by catalyzing the synthesis of ATP.

F₁ phosphorylates ADP to ATP.



TP synthase – the three catalytic sites cycle through three conformational states: O [open], L[loose binding], T [tight binding]. Proton flux through the synthase drives this interconversion of states. The essence of this proposed mechanism is that proton flux lead to the release of tightly bound ATP.

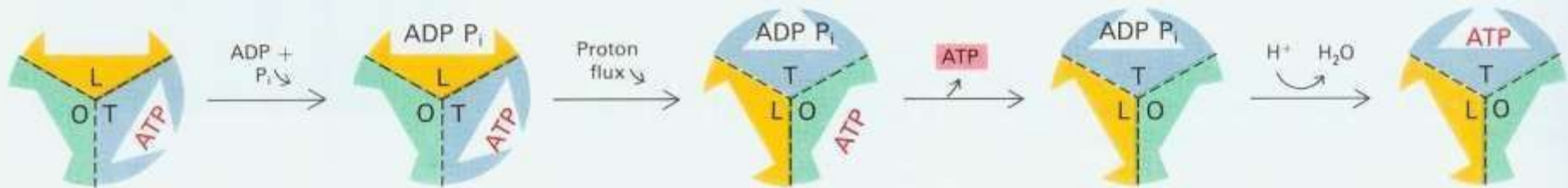

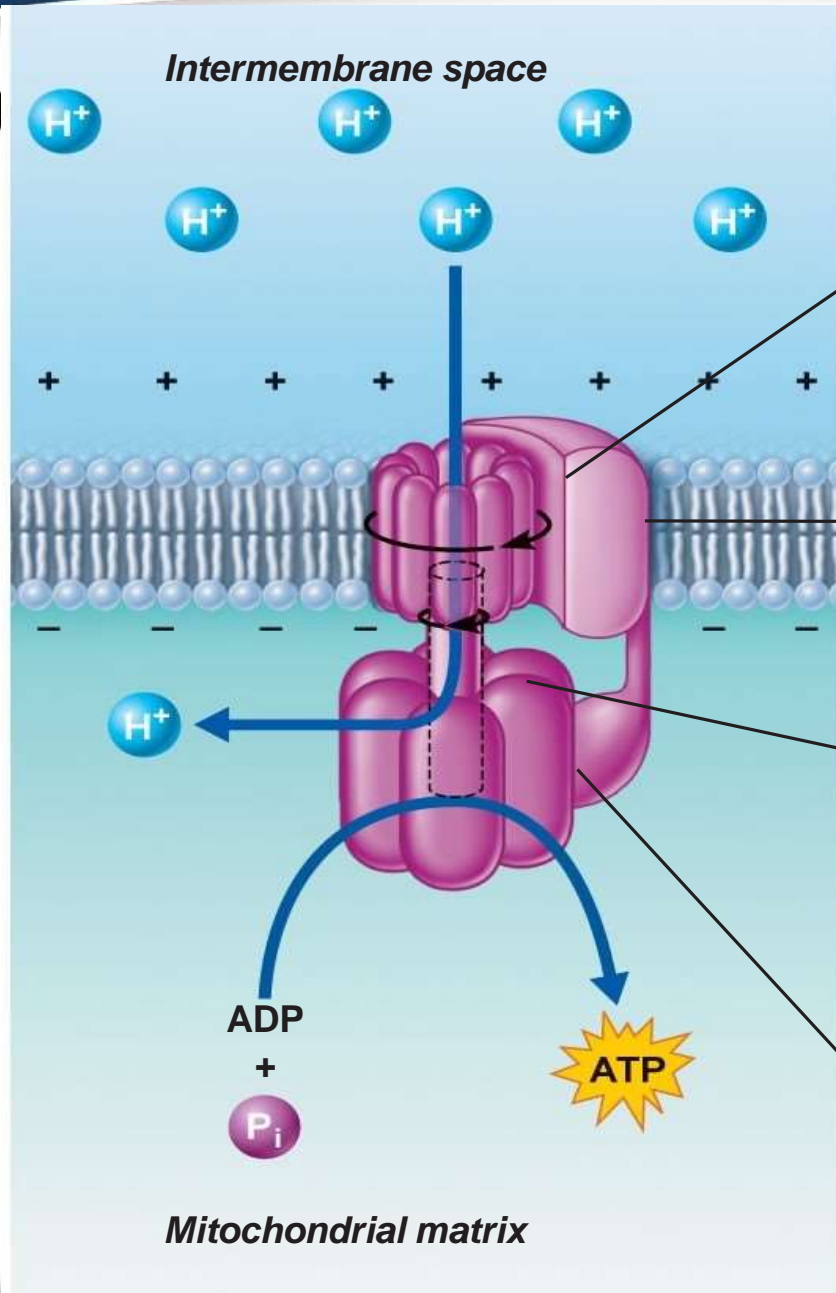

A rotor in the membrane spins clockwise when H^+ flows through it down the H^+ gradient.

A stator anchored in the membrane holds the knob stationary.

As the rotor spins, a rod connecting the cylindrical rotor and knob also spins.

The protruding stationary knob contains three catalytic sites that join inorganic phosphate to ADP to make ATP when the rod is spinning.

**TABLE 19–5****ATP Yield from Complete Oxidation of Glucose**

Process	Direct product	Final ATP
Glycolysis	2 NADH (cytosolic)	3 or 5*
	2 ATP	2
Pyruvate oxidation (two per glucose)	2 NADH (mitochondrial matrix)	5
Acetyl-CoA oxidation in citric acid cycle (two per glucose)	6 NADH (mitochondrial matrix)	15
	2 FADH ₂	3
	2 ATP or 2 GTP	2
Total yield per glucose		30 or 32

*The number depends on which shuttle system transfers reducing equivalents into the mitochondrion.

Table 19-5

Lehninger Principles of Biochemistry, Fifth Edition

© 2008 W. H. Freeman and Company



Thank
You