

FISH MEAL PROCESSING

Procedures in fish meal processing

- heating, which coagulates the protein, ruptures the fat depots and liberates oil and physico-chemically bound water;
- pressing (or occasional centrifugation), which removes a large fraction of the liquids from the mass;
- separation of the liquid into oil and water (stickwater). This step may be omitted if the oil content of the fish is less than 3%;
- evaporation of the stickwater into a concentrate (fish solubles);
- drying of the solid material (presscake) plus added solubles, which removes sufficient water from the wet material to form a stable meal,
- grinding the dried material to the desired particle size.

This chapter deals in some detail with the most generally practised method of large-scale production. A more cursory description is given of small-scale processing and plants designed to handle small and irregular landings of fish or to yield products with special properties. Although the basic principles of the process may appear few and simple, a variety of elements is required to make a smooth running and profitable factory. There are also different types of equipment that will do the same job but in different ways. The number of options have increased considerably during the last years, particularly in the fields of energy saving, automation and environmental protection. The prospective manufacturer should therefore devote ample time and attention for consultations with the most competent suppliers of machinery and complete factories, before making his final decisions on layout and equipment.

Here are some factors that need special consideration at the planning stage. The most important prerequisite for a profitable fishmeal project is an ample and regular supply of raw material at an acceptable price. Length of season, that is how many days per year the plant may be in operation, is of the utmost importance for the profitability of the venture. Furthermore, the longer the season, the greater the weight that should be placed on measures to reduce the variable costs, and the more that should be spent on investments to save labour and energy and to ensure higher yields and quality of the products.

Another important point relates to the size of plant needed for the amounts of raw material in question. Capacities given by the equipment manufacturer, particularly for the cooker and press installation, may serve only as indicators at the preliminary discussions. The yield is an empirical value entirely dependent upon the nature of the raw material to be processed, its size, freshness and texture. If experience is not available for the actual fish species it is, therefore, advisable to run some tests to evaluate the behaviour of the raw material and the performance of the cooking/pressing operation.

The composition of the raw material expressed in terms of dry matter, protein and fat, will determine what yield of products may be expected. The fat content is of special importance at the planning stage, because it will decide whether it will pay to install equipment for the recovery of oil, besides telling what yield of oil may be expected. For all practical purposes, one may reckon that for the processing of fish with less than 3% of fat, one may omit the installation of oil- recovery equipment.

Evaporators for the stickwater, however expensive, may today be considered standard items of equipment for fishmeal plants, because they recover dry matter that will increase the yield of meal by 20% or more, depending upon the freshness and nature of the raw material. Furthermore, they eliminate a serious pollution problem that today appears unacceptable, particularly in the vicinity of densely populated areas. For small factories and irregular operation, omission of evaporators may sometimes be justified, but a final decision on this point should be taken only after careful calculations have been made and the pros and cons thoroughly evaluated.

Location of the plant relative to habitation and closed harbours is another feature of the utmost importance for trouble-free operation. Public regulations protecting the environment against undesirable pollution of air and water should be carefully studied, as these will affect the selection of equipment and factory premises and determine the amount necessary for investment in unproductive installations for odour abatement and cleaning of waste water emissions.

1 The Principal Method of Processing

The bulk of the world's fish meal and oil is today manufactured by the wet pressing method. The main steps of the process are cooking for coagulation of the protein thereby liberating bound water and oil, separation by pressing of the coagulate yielding a solid phase (presscake) containing 60-80% of the oil-free dry matter (protein, bones) and oil, and a liquid phase (press liquor) containing water and the rest of the solids (oil, dissolved and suspended protein, vitamins and minerals). The main part of the sludge in the press liquor is removed by centrifugation in a decanter and the oil is subsequently removed by centrifuge. The stickwater is concentrated in multi-effect evaporators and the concentrate is thoroughly mixed with the presscake, which is then dehydrated usually by two-stage drying. The dried material is milled and stored in bags or in bulk. The oil is stored in tanks.

Figure 2 shows the flow diagram of a typical fishmeal and oil plant. As already pointed out, there are alternatives to this layout and also different types of equipment to choose among for some of the unit operations. The most important alternatives will be mentioned in the following descriptions of the various processing steps.

Referring again to Figure 2, we shall now follow the material step by step through the factory. The raw material is first unloaded from the fishing vessel by crane, wet fish pump, pneumatic elevator or some sort of mechanical conveyor. The fish is weighed or measured by volume before it is transported to the pits or tanks for the storage of raw material.

Large fish are hashed (A) while smaller fish (for example, those less than 40 cm long) are fed directly at a constant rate by the feeding machine (B) to the indirect steam cooker (C). The coagulated mass is pre-strained in a strainer conveyor (D), or in a vibrating screen, before entering the twin screw press (E). The products from the press (presscake and press liquor) are treated as follows. The presscake is disintegrated in the tearing machine (wet mill)(F) to facilitate mixing with stickwater concentrate (see below) and drying in an indirect steam dryer or a direct flame dryer (G). The meal passes through a vibrating screen (H) furnished with a magnet to remove extraneous matter like pieces of wood and metal (for example, fish hooks) before entering the hammer mill (J). The ground meal is automatically weighed out in bags by the scales (K), the bags are closed (e.g., by sewing) and conveyed to the store. Alternatively, the meal is stored in a holding and blending silo before bagging, pelleting or storing in bulk.

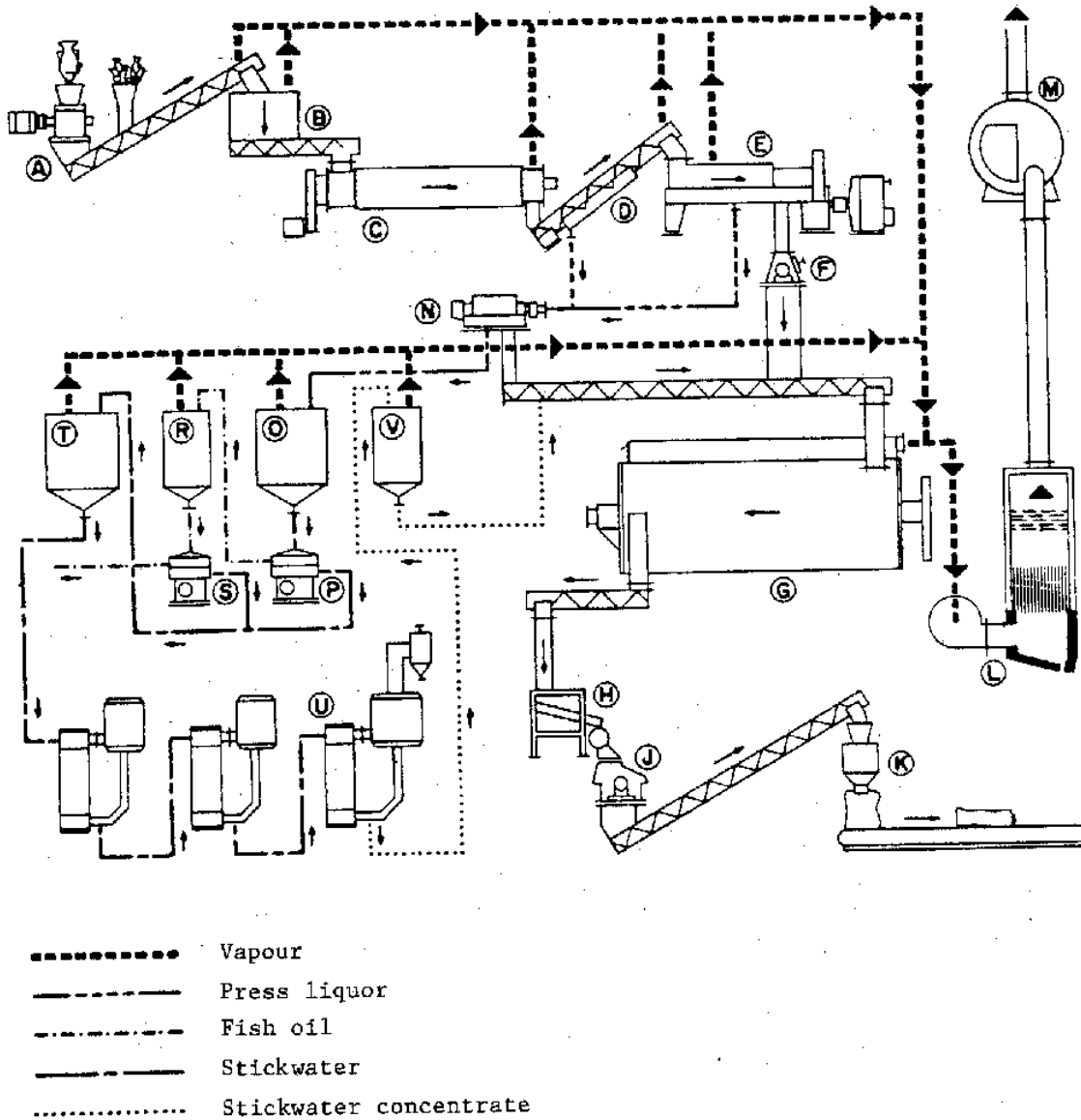

Figure 2 Layout of a fishmeal plant

To remove most of the sludge, the press liquor passes through a decanter (N). The press liquor then passes through a buffer tank (O) before separation into oil, stickwater and fine sludge in the stickwater centrifuge (P).

The sludge is added to the presscake. The oil passes through a buffer tank (R) before water and sludge impurities are removed (polishing) in the oil separator (S). After polishing, the oil often passes through an inspection tank before storage in the oil tank. The stickwater passes through a buffer tank (T) before concentration in a multi-effect evaporator (U). After the buffer tank (V), the concentrate is mixed thoroughly with decanter-sludge and presscake before drying. In some cases the stickwater concentrate, called condensed fish solubles, is sold separately.

As indicated in Figure 2 (heavy dotted line), the factory can be deodorized by air suction from all tanks and machinery. The air passes through a scrubber {L} and is then burned in the steam boiler or treated with chlorine, after which a further scrubber removes residual chlorine. Methods of effective deodorization are still under study and reference should be made to Section 4.

As stated, large fish have to be hashed into smaller pieces before being passed by the feeder into the cooker. This is to ensure uniform processing and equal temperature in the cooked material. Also, the feeder ensures a steady rate of presentation to the cooker. Figure 3 illustrates one type of hasher often used. It consists of a rotor with staggered knives and a frame with a row of stationary knives.

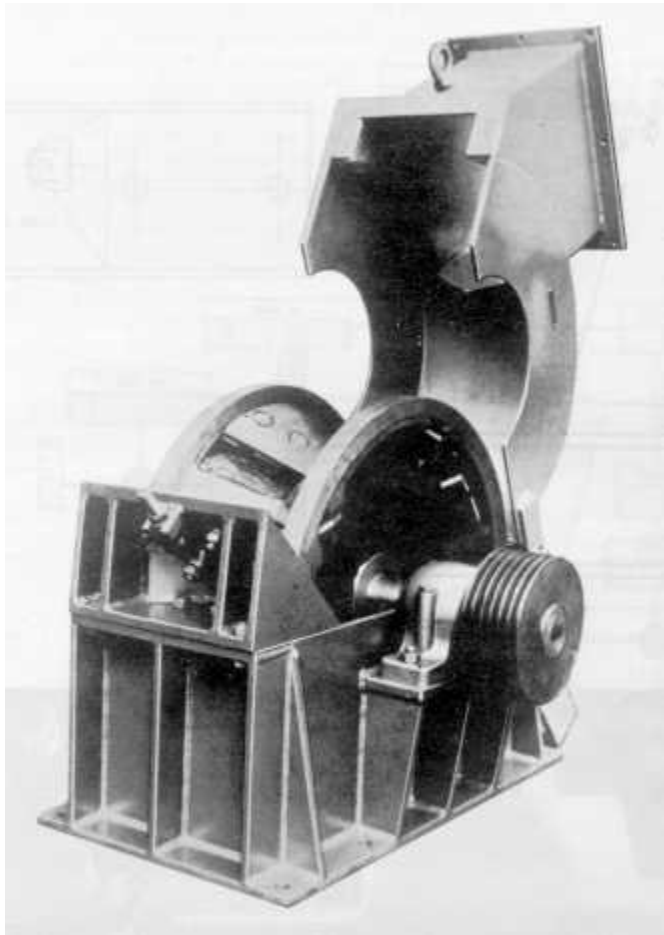

Figure 3 Hasher

Figure 4 illustrates an example of a feeder. It consists of a hopper from the bottom of which the raw material is carried to the cooker by a screw conveyor. The conveyor's speed may be adapted to the rate of throughput desired by means of a stepless gear. When the hopper is full of raw material, a level control mechanism stops the removal of raw material from the raw fish pits or silos. When the level has sunk to a fixed lower level, another level controller starts the intake flowing again. Today pumps are increasingly used for the transportation of raw material, and these can easily be controlled by the automatic level controller of the hopper.

Figure 5 gives an example of a so-called mass balance. Here we can follow the streams of the three major fractions of the raw material, solids (fat-free dry matter), oil and water, through the factory. The actual figures will, of course, vary with the composition of the raw material, particularly with the oil content, but the diagram is sufficient to illustrate the general trend. The prospective manufacturer may estimate his expected yield of meal on the basis of the dry matter content of his raw material plus moisture and residual fat in the meal. For instance, if the dry matter content of the raw material is 18%, and moisture and fat together make up 20% of the meal. The expected yield of meal will be $(18 \times 100)/80 = 22.5\%$ by weight of the raw material. Likewise, the yield of oil will be the fat content of the raw material less the small amount (2.5-3%) remaining in the meal.

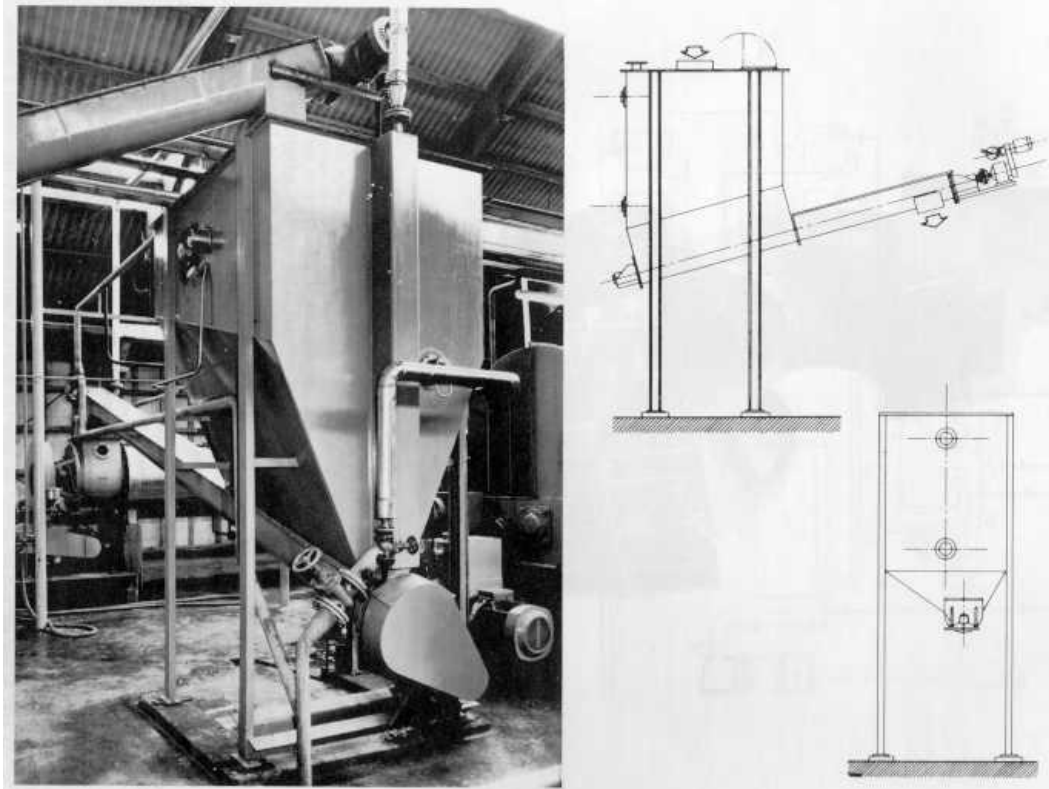

Figure 4 Feeder

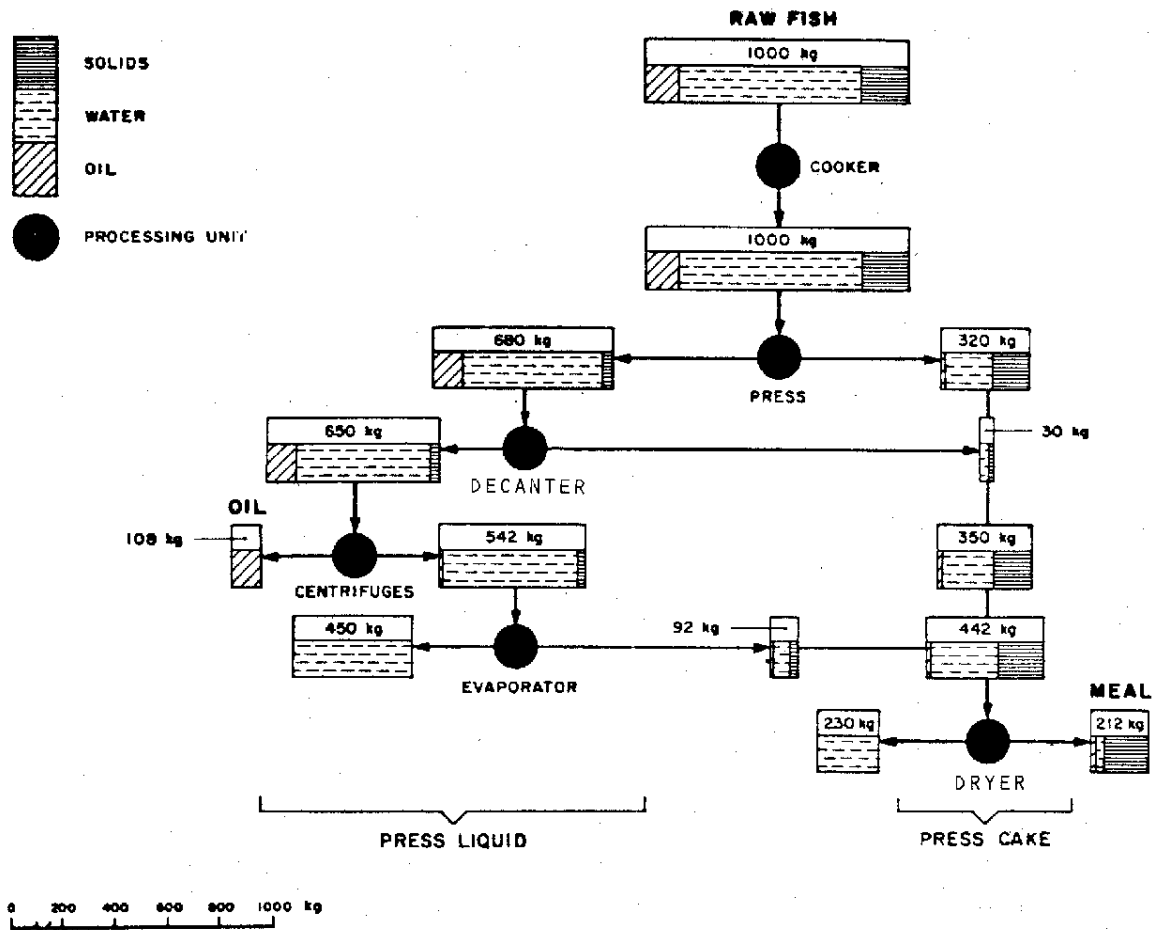

Figure 5 Mass balance in fishmeal production

In the following sections we shall take a closer look at the various unit operations of the process.

1.1 Heating ("cooking")

The purpose of the heating process is to liberate the oil from the fat depots of the fish, and to condition the material for the subsequent treatment in the various processing units of the plant. "Cooking", as this operation has traditionally been called, is therefore a key process of the utmost importance for the whole functioning of the factory.

Until fairly recently, the general view has been that the best results and optimum performance of the plant would be obtained at the highest possible temperature which, at atmospheric pressure, would be 100 °C. New experiments, however, have shown that the walls of the fat cells are broken down before the temperature reaches 50 °C. The oil is then free, and theoretically it should be possible to separate it from the solid material. Another important observation from recent investigations is that coagulation of the fish protein is completed at about 75 °C and, furthermore, that the process is very rapid. This new experience leads to the conclusion that there is very little, if anything, to be gained by heating the material beyond 75 °C or by using a long heating time. The problem is primarily a question of heat transfer and temperature control

to ensure a uniform, optimum temperature throughout the whole mass. Since reduction of heat load on the material, that is the combined effect of temperature and time, tends to improve the quality of the products, we may expect new technological answers to the heating problem, in line with this new knowledge. However, at the present state of technology, we have to accept that optimum conditions for a particular type of raw material must largely be established through practical experience.

The most common practice is to cook the fish in a steam cooker, through which it is conveyed continuously. Heat is generally transferred indirectly from a surrounding jacket and a heated rotary screw conveyor. This is an improvement over the direct steam injection cooker, in which water is condensed in the mass during the process and has to be removed by the press and then evaporated from the press liquor. However, in indirect cookers provision is also made for the admission of live steam directly into the mass as this may sometimes be advantageous.

Cooking is an exacting operation in production and is sometimes difficult to control. Production of cooked material which can be readily pressed is dependent on the quality of the raw material and on the process conditions. A precise time-temperature programme for this process can therefore not be set up and, as mentioned above, a process of trial and error is generally required when fish of unknown history is processed. The most common practice of cooking good raw material, however, is to heat to 95°-100 °C within 15 to 20 min. Most manufacturers operate cookers to ensure rapid heating of the mass to a temperature of about 95° C. The proof of good cooking is good pressability of the mass which leads to proper removal of press liquor and, in particular for fatty fish species, efficient recovery of oil, giving a meal with low fat content which is a criterion of quality. The process must be controlled to ensure sufficient cooking, but overcooking must be avoided as this results in problems with pressing and the presence of large amounts of suspended particles in the stickwater, which makes evaporation difficult.

A typical continuous indirect cooker is shown in Figure 6. The cooker is designed as a cylinder having a steam heated jacket throughout and a steam heated rotor, designed as a screw conveyor with hollow flights. The cooker is equipped with covers throughout for inspection and cleaning and with a nozzle system for blowing direct steam into the mass. The cooker may be provided with automatic temperature control equipment, automatic level control for raw material feeding, discharge control equipment (which is required particularly for handling soft raw material) and a trap for collecting heavy foreign matter like stones and scrap iron. Cookers like this are generally available in sizes which can process from 16 t to 1 600 t of raw material per 24 h.

The capacity of a heat exchanger, such as an indirect steam cooker, is proportional to the area of the heating surfaces and to the temperature difference between the two sides of the wall.

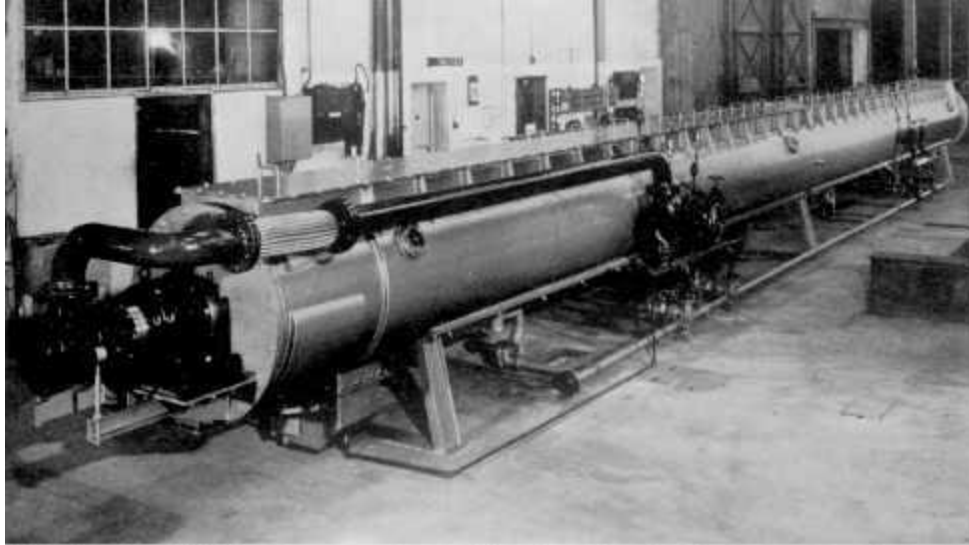
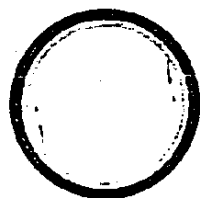
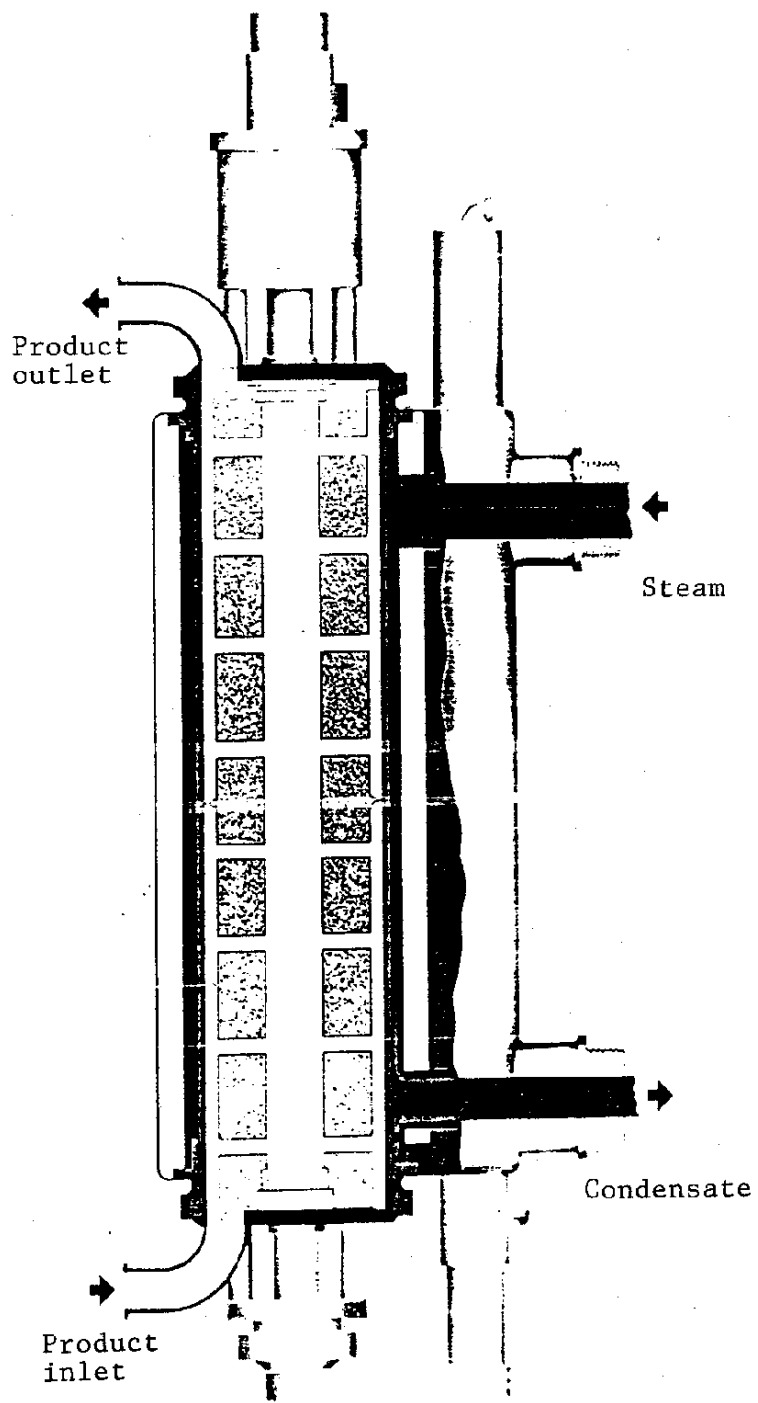

Figure 6 Cooker

Furthermore, the capacity is influenced by the resistance to heat transfer largely caused by the existence of films and coatings on the heating surfaces. An important way of reducing the tendency to scaling, caused by coagulation of protein on the hot walls, is to use moderate steam temperatures, especially in the early stages of heating. Another measure is, of course, to introduce and enforce good routines for effective cleaning at regular intervals.

An entirely different type of heating device is the so-called Contherm apparatus, recently tried out in connection with fishmeal and oil manufacture. The results, so far at low rates of throughput, have been quite promising. The apparatus shown in Figure 7 consists of a vertical cylindrical heat exchanger provided with an agitator keeping the material in rapid movement, thus contributing to effective heat transfer. During rotation, the agitator blades (knives) are pressed against the surrounding heating surface in order to prevent the formation of scale. To reduce the viscosity of the material and to increase the rate of heat transfer, some stickwater should be added to the fish. Advantages of the Contherm heater are rapid heating with a holding time less than 2 min, effective temperature control, and quick and easy routines for dismantling and cleaning.



Cross-section

Figure 7 Contherm - the vertical short-time continuous cooker for fishmeal

Another innovation is the tubular heater (pre-cooker) primarily designed and used for the utilization of waste heat, either from the evaporators or from the dryers. Because of the relatively low temperatures of these vapours or gases, they are particularly useful for preheating the raw material. The heater consists of a set of tubes coupled together and surrounded by a cylindrical jacket. The raw material is moved through the tubes by pumping, and on its way it is heated by the hot gases circulating around the tubes, in the space between the latter and the jacket. In practical use, the raw material may reach temperatures in the range of 50° to 60 °C before it leaves the pre-heater and enters the conventional indirect steam cooker. Besides representing an important saving of energy this way of operation reduces the problem of scaling on the heating surfaces considerably, implying that the capacity of the heating units may be maintained at a high level for longer periods.

1.2 Pre-straining

One result of the heating process is that the oil and a major part of the water is released and to a large extent may be removed from the solids by simple draining. Removal of more liquid is achieved by subsequent treatment of the solid part in presses or centrifuges, or in a combination of the two.

To facilitate the functioning of the press, the liquid liberated in the cooker is drained from the coagulated fish pulp in a strainer conveyor or in a vibrating or rotary strainer. Figure 8 shows a strainer conveyor set at an incline between the cooker and the press. It is designed on the same principle as that of a screw conveyor except that the lower end (that closer to the cooker) is fitted with an easily replaceable strainer in the shape of a half cylinder. Strainers with different sizes of perforations may be required for various types of fish. Figure 9 shows a vibrating strainer. The fundamental principle here is that the cooked material is conveyed to a strainer which is kept vibrating by an electric motor. The liquid phase passes through the strainer holes whereas the solid phase is vibrated along the surface of the strainer to an outlet.

1.3 Pressing

To ensure free drainage of liquid in the press, the material should be porous; that is, there should be many open channels in its mass for the passage of liquid. Cooked material from small and autolyzed fish will, as a rule, contain large quantities of fine particles (sludge) that tend to clog up these channels. In such cases, the porosity of the presscake may be improved by increasing the diameter of the holes of the pre-strainer. A greater part of the fines will then follow the liquid phase and not hamper the function of the press. To take advantage of this measure, the capacity of the decanters (desludging centrifuges) should be sufficient to handle the increased volume of sludge in the liquid.

The purpose of the press is to squeeze out as much liquid as possible from the solid phase. This is important not only to improve the oil yield and the quality of the meal, but also to reduce the moisture content of the presscake as far as possible, thereby reducing the fuel consumption of the dryers and increasing their capacity.

Two types of continuous press are used in the fishmeal industry; these are provided with either one or two screws. Both work on the principle of helical screw conveyors rotating in a tightly fitting cage, which is provided with perforations for the drainage of press liquid. The screws are

made with a taper, thus ensuring that the volume between the flights is gradually reduced. This means that the material, during passage along the press, is subjected to increasing pressures and, as a consequence, additional amounts of liquid are expressed. The performance of the press is largely determined by the profile and the compression ratio of the screws, that is, the ratio between the flight volumes of the inlet and outlet flights. Whether standard screws based on fish of average nature and quality, or screws with a special profile and compression ratio should be used, is a question for careful consideration and discussion with the press manufacturer.

Occasionally difficulties are experienced, particularly when processing soft and autolyzed fish. The press "slips", meaning that the screws rotate in the material without conveying it forward. This problem may be minimized by incorporating special devices in the single screw press; but the most efficient measure is to use two screws mounted side by side and rotating them in opposite directions.

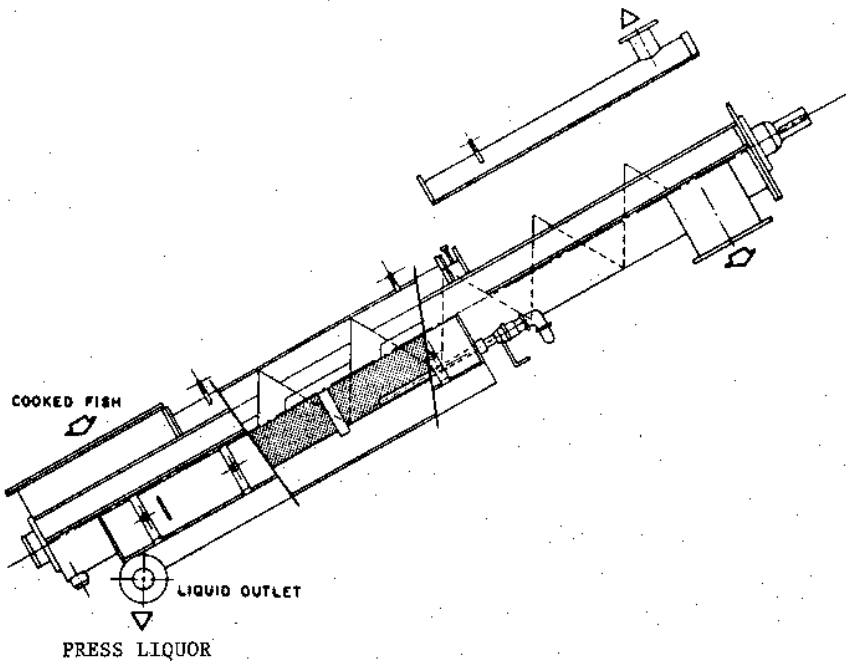

Figure 8 Strainer conveyor

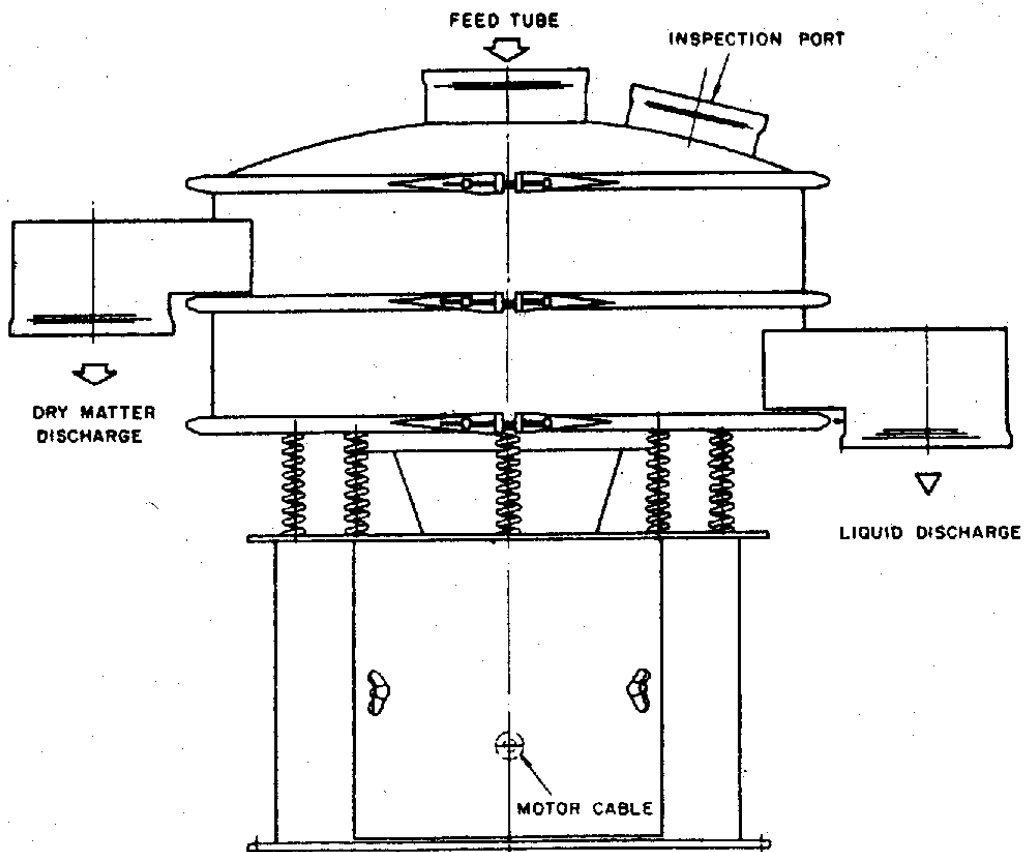

Figure 9 Vibrating strainer

For this reason the twin screw press has become the most commonly used type of press. Modern presses are very efficient dewatering devices, yielding presscakes with moisture contents as low as 50%.

Figure 10 illustrates the principle of the twin screw press. Pressing is carried out in a press chamber consisting of two hollow interlocked cylinders. The cylinder wall is made of heavily supported strainer plates made from stainless steel. The two press screws have tapered shafts and the screw pitch varies so that the pitch, and thus the flight distance, is greatest at the thin end of the shafts. The screws rotate in opposite senses. The material is fed in at the end where the shafts are thinner, and is carried towards the end where they are thicker. As can be seen, the space for the material gradually reduces and, to compensate, liquid is pressed out through the strainer plates surrounding the screws.

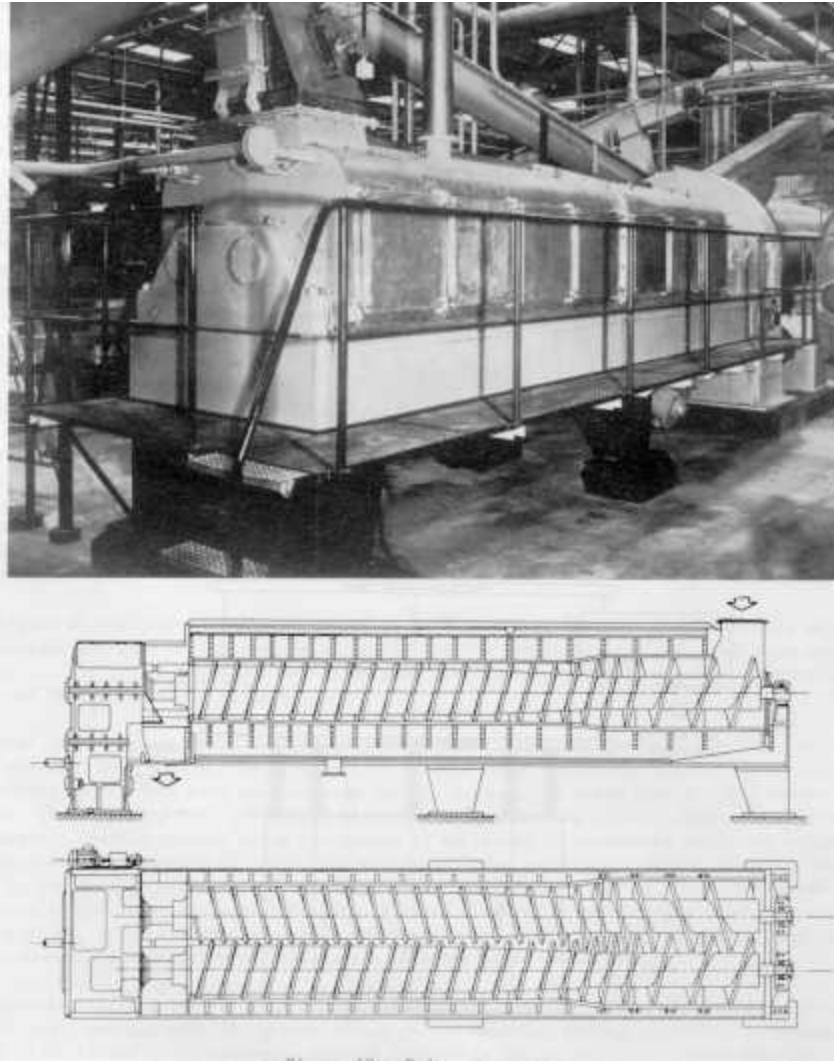

Figure 10 Twin screw press

The performance of the press may be regulated in two ways: one may adjust the level of cooked material in the hopper above the press, a high level resulting in higher pressure and consequently a more complete filling of the inlet screw flights; the other factor is the rate of revolution of the screws; increased speed means greater throughput and a shorter pressing time. How to adjust these two factors to obtain optimum performance is largely a matter of experience and skill.

Good performance of the press depends upon relatively tight fitting of the screw flights to the surrounding strainer plates. If the distance between the flight tops and the screens becomes too wide, for instance after long wear and tear, both the efficiency and the capacity will suffer; rebuilding and readjustment of the screw flights are then necessary. Another factor that needs continuous surveillance is the performance of the strainer plates. Regular inspection and cleaning is necessary to ensure that the holes are open and allow free escape of liquid. As pointed out earlier, temperature is a factor of great importance for the whole cooking and pressing operation. Basic information today indicates that moderate temperatures are preferable from the standpoint of release of oil and denaturation of protein. On the other side, high

temperatures reduce the viscosity of the oil and tend to facilitate the flow from the solid phase. With the equipment we just have described, we must again rely on experimental data to establish optimum conditions for a particular raw material.

Processing problems may be encountered under two entirely different conditions. One relates to completely fresh fish that tends to retain more oil and water than desirable. For the time being, there is no solution to this problem except by resorting to one of the two equally deplorable measures; either by reducing the speed of the press and thereby the capacity of the whole plant. Or by storing the fish for a day or two before processing. thus leading to deterioration of quality.

The other situation occurs with soft and autolyzed fish. As mentioned in the introduction to this section, the answer to this problem is to bleed off in the pre-strainer more liquid and fines to be handled by the decanters. Some processors will often resort to the use of coagulating agents like formaldehyde, which help to solidify the material and improve the performance of the press. This, practice, however, should be restricted as far as possible because formaldehyde reacts with the essential amino acid lysine, and thereby reduces the nutritional quality of the protein. Calcium chloride (CaCl_2) has also been used as a hardener, but this practice was abandoned because it raised the chloride content of the meal to unacceptable levels, particularly in cases where stickwater is incorporated and whole meal produced.

1.4 Centrifugation instead of pressing

To separate solids from liquid by centrifugation is a standard operation in many industries including the fishmeal and oil industry. With the development of centrifuges that can handle materials with high contents of solids and at high rates of throughput, it is now possible to use decanters instead of presses to separate the solids from the liquid in cooked fish. (For a detailed description of the equipment see Figure 11 and Section 3.1.5). The advantages are several. First, it presents a simplification of the process. Secondly, centrifugation is a better known and more controllable unit operation than pressing and filtration. Thirdly, centrifugation is a much quicker process than pressing and significantly reduces the heat load on the material, a factor of importance for the manufacture of special products. Perhaps the most important advantage is the ability of the centrifuge to process soft and very fluid material where the press would fail completely. Better hygiene and simpler procedures for washing operations are further features on the plus side.

On the negative side one should note that the centrifuge will discharge the solids with a higher moisture content than the press. This means increased fuel consumption for the drying operation. Furthermore, the centrifuge tends to produce more emulsions and fines, causing problems in the subsequent separation of oil, water and sludge in the liquid phase.

Plants with decanters instead of presses are in practical operation in many parts of the world, generally with small or medium rates of throughput, ranging from 12 to 300 t of raw material per 24 h.

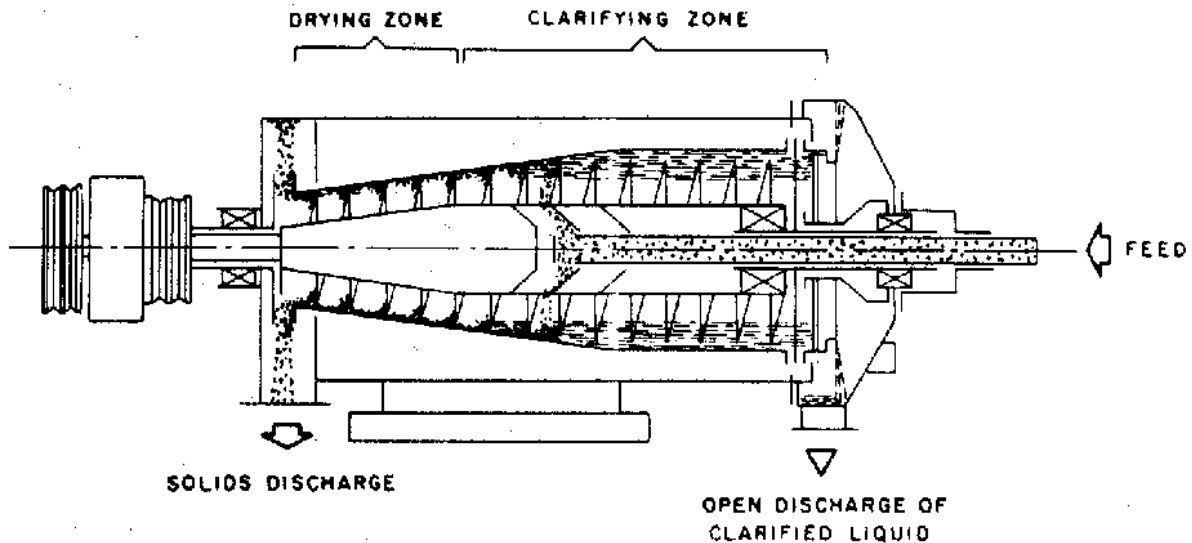

Figure 11 Decanter

Although the use of decanters for the separation of solids and liquid in cooked fish material for the time being appears relatively unimportant, centrifugation is an interesting area where we may expect new developments. Combinations of press, strainer and centrifuge in various ways also open interesting possibilities which should prove worthwhile investigating.

1.5 Separation of press liquor

The liquor coming from the press and the pre-strainer consists of water and varying amounts of oil and dry matter. The oil content is related to the proportion of oil in the fish. The content of dry matter, occurring both in dissolved and suspended (finely dispersed) forms, varies with the size and quality of the fish and with the extent of mechanical handling prior to processing.

The quantity of press liquor will also vary with the nature and quality of the raw material, and increases particularly with advancing autolysis of the fish. Under average conditions one may estimate the volume of press liquor at about 70% of the raw material while the remaining 30% makes up the presscake.

The separation of the three fractions of the press liquor, sludge, oil and water, is based on their different specific gravities. If press liquor is left for some time in a tank, it will settle out in three layers: sludge at the bottom, water in between and oil at the top. In the early days of fish oil production, this method of settling under the influence of gravity alone was standard procedure. It had many drawbacks such as poor yield, impure fractions and, above all, it was extremely slow. With centrifugation we get several thousand times greater forces at our disposal, and the separation process may now be accomplished in seconds when compared with the hours required for the settling method.

An important prerequisite for efficient separation is high temperature, implying that the press liquor should be reheated to 90°-95°C before entering the centrifuges. This applies to sludge removal as well as to separation of oil and water.

The suspended solids are first to be removed. This is done in a horizontal centrifuge, a so-called decanter or desludger, the principle of which is shown in Figure 11. It consists of a partly cylindrical and partly conical rotor drum (bowl) and, inside this, a screw conveyor of the same shape. The press liquor is fed into the rotor where, by centrifugal force, it is thrown toward the bowl's periphery. The denser solids are rapidly precipitated along the inside rotor surface. The screw conveyor rotates with the bowl, but at a rate some 30 to 50 rpm faster than the speed of rotation of the drum; the deposited solids are thus scraped off continuously. Before being discharged, they are lifted out of the liquid phase and pass through a drying or dewatering zone.

The performance of the decanter may be controlled in two ways. It is possible to adjust the thickness of the liquid layer (a thick layer represents a longer zone and allows more time for clarification of the liquid) and, associated with this, there will be a correspondingly shorter zone of sludge and less time for dewatering the solids. The reverse will, of course, be the case with a thin liquid layer. The other regulating parameter is the speed of the screw conveyor relative to that of the bowl. The higher the content of solids in the liquid the faster the conveyor should rotate in relation to the bowl in order to remove the precipitate. In addition to these parameters one may naturally influence performance by regulating the feed. Optimum conditions are dependent both on quantity and nature, specially particle size, of the solids in the liquid. Decanters are available in various sizes.

For smaller plants, the investment in a decanter may not be economically justified. In such cases a vibrating strainer, although less efficient, may be a cheaper but entirely satisfactory solution.

Separation of stickwater from oil takes place in vertical disc centrifuges, either of the nozzle type, which discharge the stickwater and remaining sludge continuously, or of the self cleaning type, which is often preferred. In the latter, the stickwater is continuously discharged, whereas the sludge is collected in the bowl and periodically ejected according to a timed programme which depends on the quantity and the nature of the sludge. The stickwater with a dry matter content of 6-9% is concentrated in evaporators. The sludge in most cases can be pumped to the presscake.

Figure 12 illustrates the principle of the self-cleaning disc centrifuge. The main component of the bowl is a stack of conical discs lying on top of each other at distances of 0.5 to 2 mm apart. The discs have a number of distribution holes to provide passages for the liquid from the bottom of the disc stack. The decanter liquid is fed from a control tube (1). The oil moves along the discs toward the centre and discharges through the holes in the nut (3). The stickwater moves toward the periphery and discharges behind the separating plate through the regulation ring (4). This is inter-changeable to adjust the separation. The sludge separates along the bowl periphery and is discharged through the bowl slot into the frame chute at regular intervals (2). Centrifuges are available with rates of throughput ranging from 500 to 25 000 litres/h.

1.6 Oil polishing

Oil polishing, carried out in special separators, is the final refining step done at the factory before the oil is pumped into storage. Polishing is facilitated by using hot water, which extracts impurities from the oil and thus ensures stability during storage.

The efficiency of separation depends upon both design and mode of operation of the centrifuges. The speed of separation depends upon the motility of the particles and upon the centrifugal force of the separator. Motility depends upon material properties, such as viscosity and specific gravity, which in turn depend upon temperature. Accordingly, good temperature control is required; the temperature of the feed should be maintained at about 95°C, but not less than 90°C. The centrifugal force is proportional to the angular velocity squared and to the radius of the centrifuge bowl, while the stress on the material of construction is proportional to the angular velocity squared and to the square of the radius. Centrifuges are designed to operate at high speeds and are, therefore, generally constructed with small radii. Centrifuges operating at about 5 000 rpm, yielding a centrifugal force of 5 000 x g (natural gravity), are generally used in the fishmeal industry.

1.7 Evaporation of stickwater

When decanters and separators have removed the major part of oil and suspended solids from the press liquid, we are left with the so-called stickwater. For all practical purposes, one may estimate the amount of stickwater at about 65% of the raw material. Besides water, stickwater will contain the following components:

<ul style="list-style-type: none">• dissolved protein	<ul style="list-style-type: none">• minerals
<ul style="list-style-type: none">• undissolved (suspended) protein	<ul style="list-style-type: none">• vitamins
<ul style="list-style-type: none">• residual oil	<ul style="list-style-type: none">• amines/ammonia

The content of residual oil will depend upon the efficiency of the separating process and should be as low as possible, certainly well below 1%. The other components, usually put together and called stickwater dry matter, amount to 5-6% for fresh fish, and correspond to nearly 20% of the yield of meal. After transportation and storage, specially of small fish caught during the feeding season and at high temperatures, the percentage of stickwater solids may rise to even higher values.

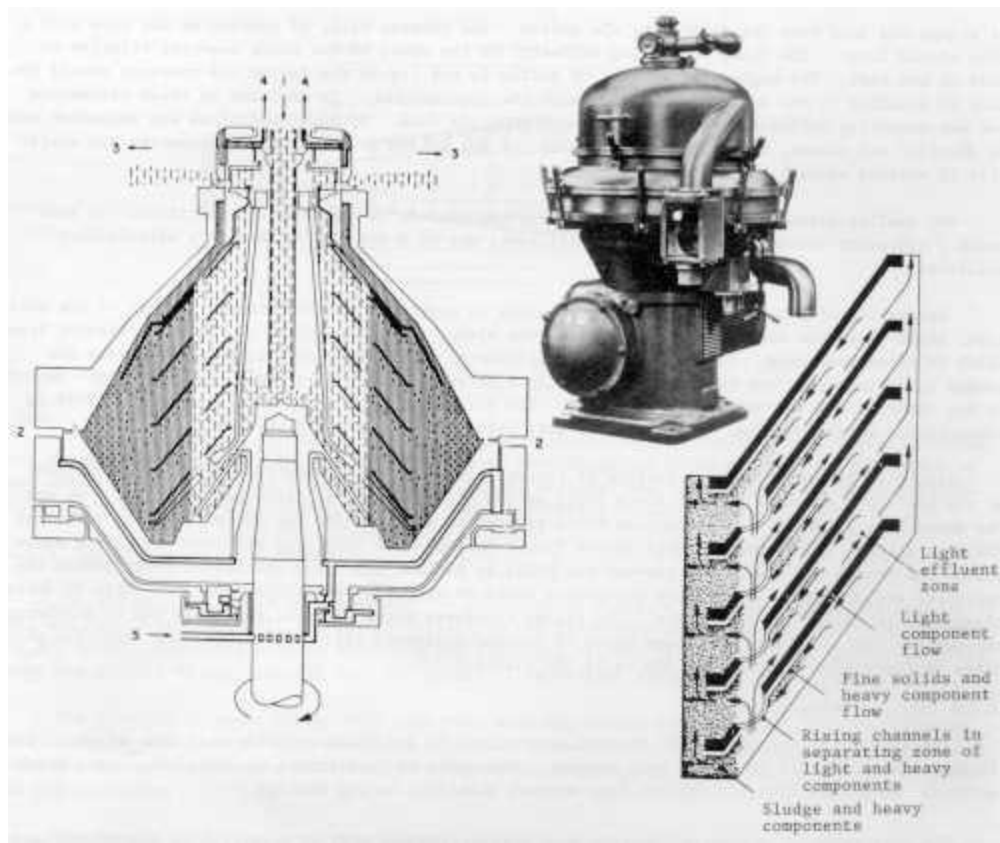

Figure 12 Self-cleaning disc centrifuge

These figures illustrate clearly the importance of recovery of the soluble dry matter in the stickwater.

To recover the stickwater solids, one has to remove large quantities of water by evaporation and subsequent drying. This requires heat, and the question of heat economy and fuel consumption becomes, therefore, of paramount importance. The usage of heat may be influenced in various ways.

At the planning stage, one should carefully consider what type of evaporating plant to select, and particularly evaluate to what extent it is economically feasible to make use of waste heat, for instance that represented by the vapors in the exhaust gases from the dryer. Furthermore, there is the question of the number of evaporation stages, increasing numbers resulting in significant reductions in steam requirement. Typical figures for steam consumption are 0.6 to 0.65 kg, 0.4 to 0.45 kg and 0.2 to 0.35 kg steam per kilogramme water evaporated in double, triple and quadruple effect evaporators, respectively. On the other hand, the costs of construction rise with increase in the number of evaporator units. Generally, large catches of fish and long periods of operation speak in favour of cutting variable costs by investing in a greater number of evaporation stages. Other factors to be considered are, of course, local prices of fuel, electric energy and capital. For general guidance, it may be mentioned that double effects are used for rates of throughput of 30 to 150 t, triple ones for 200 to 400 t and quadruple for 500 t and more of raw fish per 24 h. If waste heat evaporators can be integrated

into the system from the beginning, the picture will be changed significantly and reference is, therefore, made to Chapter 7.

Selection of the operating conditions will also greatly affect the heat economy of the whole factory. Because multiple effect evaporation is a more economical way of removing water than one stage drying, it is specially important to achieve a high concentration of dry matter in the final stickwater concentrate before it is discharged from the evaporating plant and conveyed to the dryers for drying together with the presscake. The factor which largely determines how far you may concentrate the stickwater without running into trouble is the viscosity which rises steeply during the last stage of concentration. As increasing temperatures tend to make the concentrated stickwater less viscous, one may take advantage of this fact by completing the evaporation in the unit with the highest temperature. Another factor that can contribute greatly to the viscosity of the concentrate is the content of suspended solids (sludge), and great care should therefore be taken to keep this as low as possible, both by preventive measures and by efficient removal in decanters or sieves.

Although evaporation at high temperatures offers certain advantages, there are quality considerations that pull in the opposite direction. Some of the vitamins and amino acids are particularly sensitive to heat, and heating for any length of time above 130 °C should be discouraged, as this may lead to considerable losses of vitamin B₁₂ and of the important amino acids, cystine, lysine and tryptophan. There are also other changes which take place under the influence of heat, such as degradation of the protein and evaporation of volatile components. Furthermore, there is the problem of discoloration. The significance of these changes should, of course, be carefully considered with special view to the marketing and end use of the products, before making the final decisions on equipment and operating conditions. Quality criteria will naturally centre around the nutritional value of the products but, with a view to a possible development toward products for human consumption, greater weight should be placed on sensory or organoleptic properties, like flavour and odour.

Figure 13 shows a quadruple effect plant for the evaporation of stickwater. This system works according to the I-II-III-IV mode of operation, that is, the stickwater flows in parallel with the flow of steam. It is fed continuously to stage I and progressively concentrated during the subsequent passage through stages II, III and IV. Live steam from the boiler plant is supplied to the pre-heater and to the heat exchanger of the first stage, while the vapour emanating from this stage is used for heating in the second. Vapour from the second stage is used in stage III, and so on to stage IV. Vapour from the last stage is normally condensed in a condensing tower, but it may also be used, for instance, to preheat raw material.

The conventional mode of operation is to feed dilute solution to the first stage operated above atmospheric pressure and to withdraw concentrate from the last, which is operated under reduced pressure. Some factories, however, prefer to feed dilute solution to the second stage and withdraw concentrate from the first. This subjects the concentrate to the highest available temperature in the system (generally above 100 °C), which has the following advantages: (1) reduction of viscosity of concentrate, (2) effective decomposition and removal of nitrogenous contaminants, for example nitrites and dimethyl nitrosamine, and oxides of sulphur if present, and (3) destruction of any pathogenic bacteria, including Salmonella, that might have infected the material in earlier stages. In some factories these effects are attained by treating the concentrated stickwater in separate heated pressure tanks.

During evaporation, solids are deposited on the hot surfaces impeding heat transfer and blocking the tubes. These deposits must be removed regularly, generally during shut-down periods (for example at weekends). Such removal necessitates chemical and mechanical treatments. Chemical treatment should be carried out when required, usually once a week. Mild steel evaporators may be cleaned with about 14% caustic soda solutions, recirculated at about 80°C for 5 h and left standing overnight. The apparatus is then emptied and thoroughly rinsed with water before the factory resumes normal operation. Mechanical scale removal in mild steel evaporators may be necessary several times a year. The weekly cleaning of stainless steel evaporators is usually done with stronger cleansing agents. Two hours' treatment with caustic soda will dissolve protein deposits, and a subsequent one hour's treatment with 5% nitric acid at 60°C will remove more firmly bound material. Mechanical cleaning of stainless steel evaporators should be avoided if possible but, if it should prove necessary, it should be carried out with great care to avoid scratches or other damage to the surface, which would result in loss of an important property of stainless steel, that is its smoothness. The smoother the surface the less firmly does the scale adhere to the surface. Monthly cleaning (caustic soda) on the steam side of the evaporators is also advisable. To prevent corrosion and facilitate cleaning, stainless steel tubes are recommended.

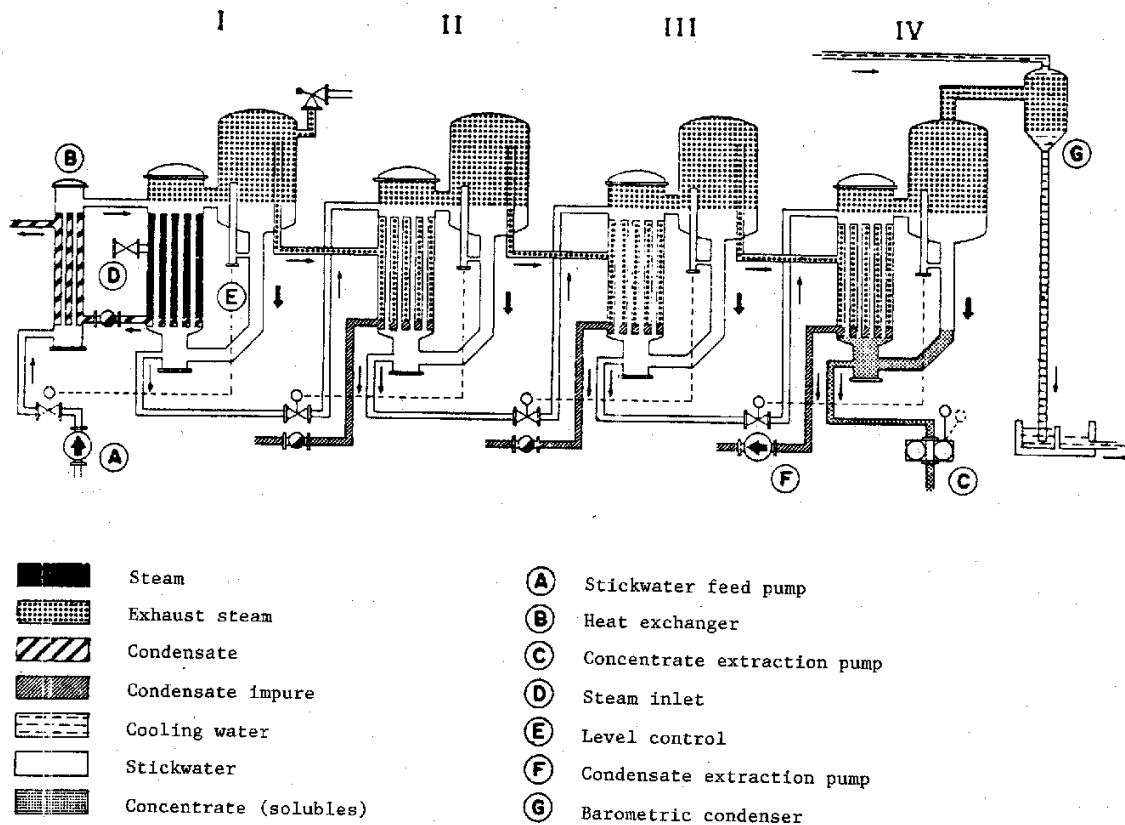

Figure 13 Quadruple effect stickwater evaporator

Oil separation from partly concentrated stickwater is practised by some manufacturers. The density of stickwater is higher in the concentrated than in the diluted state. This greater difference between the density of oil and concentrated stickwater produces an increase in the centrifugal potential and thus facilitates extra oil removal. Consequently, oil separation from the

concentrate may lead to slightly leaner "whole" fish meal and will also increase the yield of oil. Oil separation seems to be more efficient after the second evaporation step than after later effects because of the lower viscosity of the concentrate at this stage. The separated oil tends to be rather dark and of less value than oil separated before concentration. High contents of sulphur are particularly harmful because some sulphur-containing compounds act as catalyst poisons during the hydrogenation process of the edible fats industry. "Concentrate oil" should, therefore, preferably be stored and sold separately.

Stickwater concentrate may be sold separately under the name "fish solubles". Because of the character of the product, however, the market is limited and is usually located not too far from the place of production. The most common way of utilizing stickwater concentrate is to mix it with the presscake and to dry the mixture to so-called "whole meal". The dry matter content of the concentrate is determined by the viscosity/dry matter relationship for the actual raw material, and may vary between 30% and 50%.

The commonly used evaporators operate with vertical tubes partly filled with boiling liquid, gradually giving off water vapour while moving upward in the tubes and into the chamber, separating liquid and vapours. The volume of liquid is quite large and it takes, therefore, a long time before the desired concentration has been reached, and concentrate starts flowing to the dryers. This time lag between pressing and concentrating is particularly undesirable and causes problems in factories with the intermittent supplies of raw material. In such cases, the falling film evaporator becomes of special interest because it operates with a short holding time and small liquid volume. Here the stickwater enters at the top of the tubes, which are heated from the outside by steam or hot gases. On its way down, water evaporates and the liquid becomes more and more concentrated, and finally ends up at the bottom as concentrate. The falling film evaporator also offers advantages in connection with energy saving systems using vapour recompression. So far, it has found limited use in the fish-meal industry largely because it requires special skill and attention from the operator. Because of its many advantages, however, the falling film evaporator is definitely a new alternative to consider for future plants.

1.8 Drying

The purpose of the drying process is to convert the wet and unstable mixture of presscake, decanter sludge and concentration into a dry and stable fish meal. In practice, this means drying to a moisture content below 12%, which generally may be considered low enough to check microbial activity. This drying is done by heating the material to a temperature where the rate of evaporation of the water is considered satisfactory. Increasing the temperature will speed up the drying process. There are, however, certain critical limits to observe in order to avoid reduction of quality, especially of the protein.

With the equipment and conditions normally used in the fishmeal industry, the temperature of the drying material should not exceed 90°C in order not to impair nutritional value.

A prerequisite for optimum drying conditions is that the material should be divided into relatively small pieces or particles so as to facilitate the escape of water vapour from below the surface into the air. The presscake is, therefore, passed through a wet mill where it is disintegrated by fast moving hammer heads mounted on a rotor. The presscake is beaten against a screen in the bottom provided with sharp edged, square holes. Figure 14 shows an example of a wet mill.

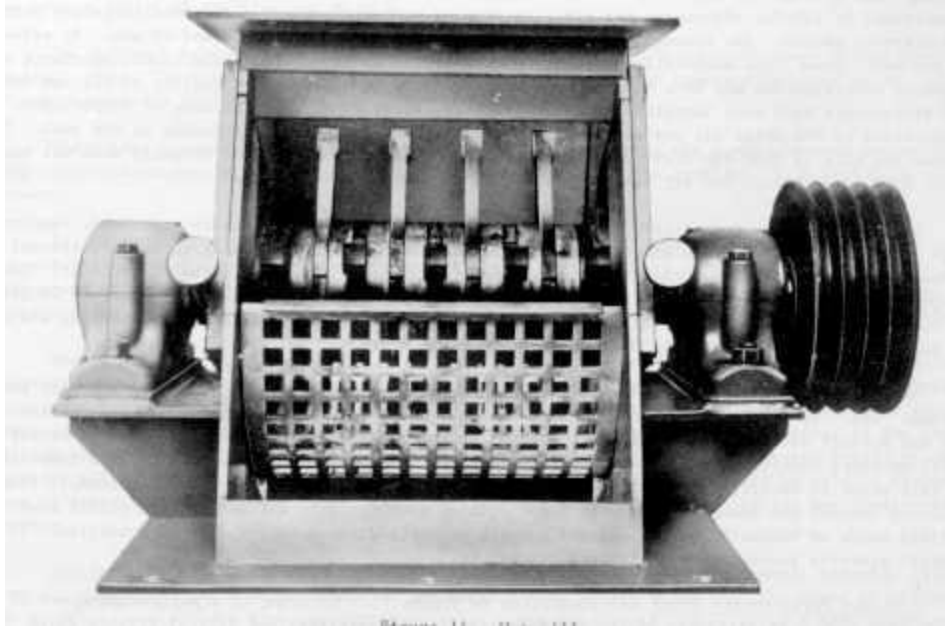

Figure 14 Wet mill

To avoid sticking and lump formation during one stage drying of presscake to which stickwater concentrate is added, thorough mixing is necessary. This may be achieved by heating the concentrate to a high temperature (about 100°C) before mixing. Such heating also serves to destroy bacteria, including *Salmonella*, if present. Mixing is generally performed in the screw conveyors, the concentrate preferably being added before disintegration of the presscake in the wet mill. In two stage drying the concentrate is added to the presscake between the dryers.

The type of dryer to be chosen will depend on several factors, i.e.:

- i. the nature of the material to be dried,
- ii. fuel economy,
- iii. plant layout,
- iv. plant capacity,
- v. odour considerations.

The two main principles of drying are direct heat drying and indirect steam drying.

The direct rotary dryer, also called "flame dryer" or "direct hot air dryer", is used in the production of some 75% of fish meal in world trade. Heat for vaporization is provided by a current of flue gases diluted with secondary air, in direct contact with the fish material being dried. The direct action of the drying medium is both the strength and the weakness of the system. It represents the most efficient mode of heat and mass transfer but, unless operated properly, it may constitute a source of contamination of the product. Flue gas contaminants may range from products of incomplete combustion, for example particles of soot, to oxides of sulphur and nitrogen which are capable of reacting with nutritional components (such as protein and oil) in the meal. Manufacturers should therefore avoid the use of the crudest types of fuel, which may contain up to 1% by weight, or more, of sulphur and nitrogen. The temperature of

combustion must be high enough to ensure complete fuel combustion; inlet air temperatures of 500° to 600°C are considered safe levels.

The direct rotary dryer is operated "in parallel" with respect to flow of air and fish material. Consequently, in addition to being the supplier of heat and the carrier of water vapour, the movement of the air also contributes to the transport of meal through the dryer. Accordingly, the air velocity must be adjusted so that the fish material is given sufficient dwell time in the dryer for proper drying. The drying time required, dependent upon process parameters and type of raw material, is established by careful adjustment for air flow coupled with measurement of fishmeal moisture during the start-up period. The average dwell time in the dryer ranges between 10 and 20 min. By adjustment of the heat input, the evaporative capacity of the dryer can be varied. This is of importance to fishmeal manufacturers who have to face large fluctuations in quantity and quality of the raw material. Air temperature is a most important control parameter, since it affects the rate of evaporation. The temperature of the inlet air may range within wide limits without apparent damage to the meal. The reason for this is that the fish itself gets cooled through evaporation and normally does not exceed about 80°C, even though the air temperature may be several hundred degrees.

Adding stickwater concentrate to ground presscake, now almost universally practised, requires high concentration and good mixing to avoid problems of wet material sticking to metal surfaces; but these may be overcome by returning an adequate portion of dried material to the dryer inlet. Two stage drying, that is two rotary dryers operated in series, is practised in many instances on grounds of fuel economy and easier control of moisture content, and in these instances the solubles are added to the partially dried presscake after the first drying stage.

Estimates of moisture content during drying are carried out manually, primarily and very roughly through "feel" of the fish meal to the hand, and by analysis. Fluctuations in moisture content of the end product are counteracted by manipulation of the hot air. Some factories employ indirect automatic moisture control based on continuous temperature measurement in the exit air. The temperature at this point is sensitive to variables in the process parameters of the system (for example flow, moisture content and homogeneity of the feed). Thus, when the exit air temperature drifts away from a fixed value an automatic device adjusts the oil burner and restores the desired condition. This control prevents gross variation in product quality.

A direct fired rotary dryer is illustrated in Figure 15. Rotating at a peripheral speed of about 1 m/s, the cylindrical compartment is equipped with horizontal and helical flights which provide cascading and good agitation of fish material, a large area of contact between fish and air and, accordingly, means for efficient dehydration. As stated, hot air is produced by mixing flue gases from oil gas or coal combustion with a stream of secondary air.

Because large seasonal catches of fish must be processed within relatively short periods of time, there has been a demand for large size rotary dryers in the industry capable of processing up to 1 000 t of raw material per day.

The indirect steam dryer works on the following principle: the mixture of presscake and stickwater concentrate is fed continuously into one end of the rotary apparatus, and is dried in direct contact with steam heated elements (tubes, discs, coils, etc.), emerging at the other end. A counter-current stream of air is blown through the dryer to facilitate removal of water vapour. The heat is transferred from the steam to the pulp through the heating surface, and rotary agitation of the pulp promotes the heat transfer.

The steam temperature (pressure) is limited by the dimensions and strength of materials of construction (discs, tubes or coils). A maximum steam temperature of 170°C corresponding to 6 atmospheres gauge pressure is most frequently used in steam dryers. Overall heat transfer is slower than in the direct dryer and a drying period of 30 min or longer is required. Figure 16 shows a rotary disc dryer. It consists of a steam heated stationary cylindrical jacket and a steam heated rotor equipped with steam heated double walled discs perpendicular to the rotor which provide good agitation and heat transfer to the fish meal. The evaporated water is removed by air drawn through the dryer by a centrifugal fan. There is an air dome on the top of the dryer to allow for the passage of air and water vapour. The entire drying process may be watched through inspection windows. The meal discharge is controlled by a gate valve at the discharge opening. These dryers normally use steam at a pressure of 6 kg/cm² and are designed to remove up to 2 700 kg water per hour, corresponding to about 300 t of raw fish per 24 h. One of the advantages of disc dryers is their ability to dry stickwater concentrate together with presscake without deposits forming on the heating surfaces.

Figure 17 illustrates the interior of a steam heated coil dryer. The main difference between this and the rotary disc dryer is the design of the rotating heating elements. The coils are mounted on a hollow shaft and supplied with steam at a pressure of about 7 kg/cm². These dryers are available with heating surface ranging between 20 and 400 m² and of handling materials corresponding to as much as 400 t of raw fish per 24 h.

The indirect tube dryer is a horizontal rotating cylinder with internal steam heated longitudinal tubes. To transfer heat from the tubes to the pulp and to remove evaporated water, air is drawn through the dryer.

The drying process in steam dryers is controlled by adjusting the steam pressure and by varying the rate of discharge of meal; the latter is done by adjusting the level of the material in the dryer.

In indirect dryers the fish meal is at no stage in contact with flue gases. The gentle transport of material through the stationary cylinder of a disc dryer appears to yield a product with a physical structure different from that of the rotary dryer. The particles are longer and less prone to spillage through grated cage floors and, consequently, the meal is more acceptable for mink feeding.

From a nutritional point of view, direct and indirect drying methods seem to yield products of equivalent value. The steam dryer has an important advantage in regard to air pollution. Owing to the small volume of effluent gases (30% or less of that of a direct heated rotary dryer of comparable capacity), odour abatement is much simpler. The great advantage of the direct dryer is the large drying capacity of each unit making for simpler machinery arrangement and cheaper installation for a given rate of throughput. With respect to heat economy, there is little to be said in favour of one or other type, when the efficiency of the steam dryer and that of the boiler are considered together.

Indirect hot air dryer have started to attract the interest of the fishmeal industry in recent years. They offer the same advantage as the steam dryers in the sense that the gases of combustion do not come into contact with the drying material. The hot air is generated in a heat exchanger where the gases from the combustion chamber move on one side of the heating surface and uncontaminated air on the other. After having transferred the heat to the current of clean air, the flue gases leave the system through the stack. With respect to the dryer itself, the performance

is very much the same as that of the direct fired rotary dryer, the main difference being that clean, hot air replaces the current of flue gases with its various contaminants.

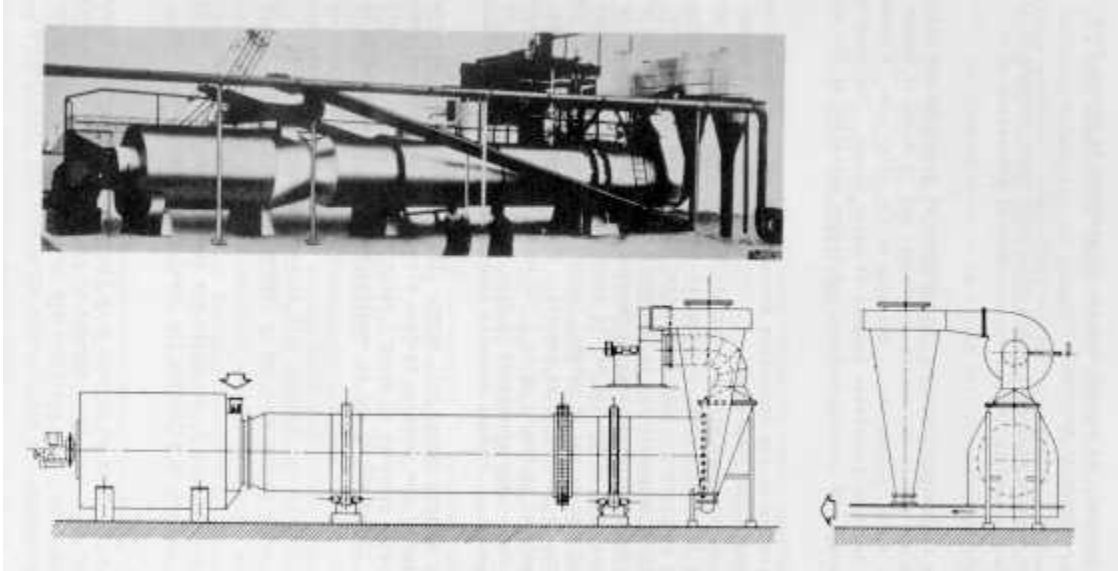

Figure 15 Direct fired rotary dryer

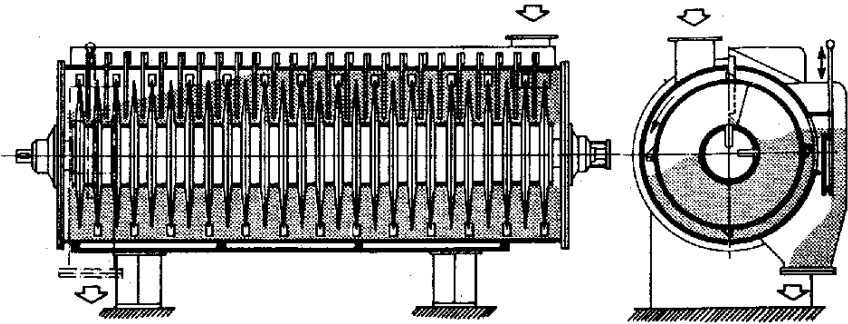

Figure 16 Rotary disc dryer

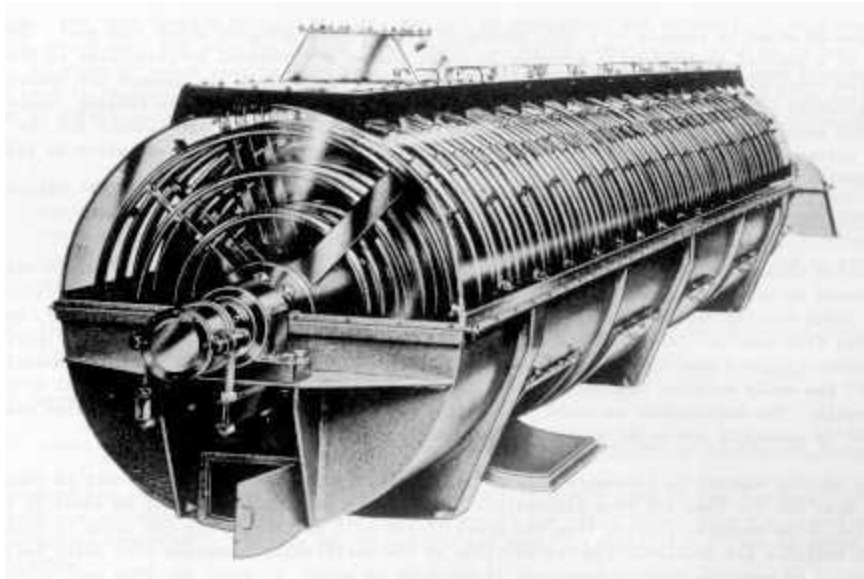

Figure 17 Steam heated coil dryer

2 Milling and Storage of Fish Meal

2.1 Milling

Before milling, the meal should pass another vibrating sieve and magnet to remove extraneous matter, like pieces of wood, cloth, fish hooks, and nails, which might still be present. The purpose of milling is to facilitate uniform incorporation in feeds. A properly milled meal has an attractive appearance and is readily mixed into feed rations which require homogeneous blending.

Different users require fish meal of different particle sizes. The ideal in milling is to produce small particles averaging around 40 mesh Tyler screen and of as even a size as possible. In practice, however, there is a great variation in particle size, ranging from 10 mesh to over 100 mesh.

Most purchasing specifications require the fish meal to pass through a 10 mesh screen, otherwise it is too coarse for uniform incorporation.

Production of excessive fines (particles below 150 mesh) should be avoided, for example by screening before milling and passing only the oversize particles through the mill. Large amounts of fines are undesirable for several reasons. They cause dusting when handled, sift through woven bags resulting in loss of weight and in pollution, cause compacting of bulk meal and tend to clog the nostrils of chickens eating the feed.

There are numerous types of dry mill on the market. In view of the need for high rates of throughput and ready access for cleaning, hammer mills have proved particularly suitable. The coarse meal is disintegrated by the impact of rapidly rotating hammers, pivoted on horizontal or vertical shafts. A grating is usually attached around the rotor which retains the meal until it is fine enough to pass through the perforations.

Figure 18 shows an example of a mill specially designed for grinding dried fish meal. The rotor consists of a central shaft to which a number of rotor plates are fastened perpendicular to the shaft. Between the rotor plates, hammers are held in position by bolts so that the hammers are removable. Special grinding plates are fixed inside the housing. At the lower part of the housing, there is a screen with round holes. By rotation of the rotor the material is hit by the hammers and the grinding plates and forced through the screens. The ground meal is cooled by air which is also used for transportation of the meal.

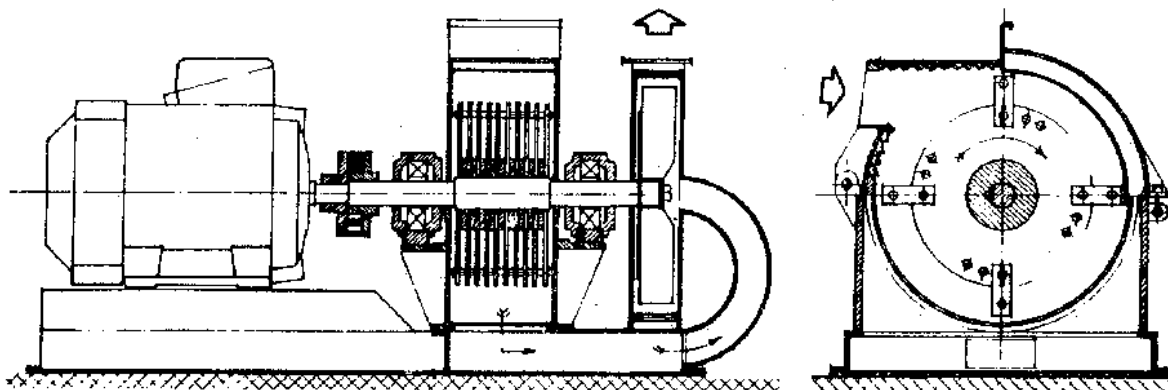

Figure 18 Grinding mill

2.2 Addition of antioxidant

Reactive fish meals are "stabilized" by means of antioxidant immediately after manufacture, and may be stored in bulk or shipped as soon as they are cooled. The amount of antioxidant required for avoiding undue heating depends on the degree of reactivity of the oil (lipid unsaturation), and varies with fish species. Considerable excesses of ethoxyquin are, however, added for safety. Thus, South African pilchard meal (iodine value about 180) is "stabilized" with 400 ppm of ethoxyquin though 200 ppm would suffice, and herring meal (iodine value about 120) by 700 ppm of BHT or 200 ppm of ethoxyquin. The antioxidant is added immediately after drying. Anchoveta meal (iodine value about 190) is generally protected by 400 to 750 ppm of ethoxyquin.

Very careful control is necessary because of the small amount of antioxidant that is added to the fish meal and the need for even dispersion. For this reason the antioxidant is added to the meal in the screw conveyor leading from the dryer to the mill so that mixing can occur en route. Automatic controls are available for the addition of the antioxidant, complete with alarm bells and other devices to warn the factory personnel if anything is amiss, to avoid any fish meal being bagged without having been adequately treated. For ethoxyquin dosage it is essential to install proper automatic control and all fish meal passing the doser after the sounding of the alarm must be diverted. until the correct dosage has been re-established, and passed through the dosing system again.

In some factories the antioxidant is mixed with a constant amount of stickwater concentrate and this solution is then added to the presscake in the screw conveyor to the dryer. The effectiveness of the antioxidant is similar, whether added before or after drying. It must be stressed that stabilized meal retains a small trace of reactivity and is not completely stable.

Nevertheless, the oil quality (energy value) is retained during prolonged storage; and, far more importantly, so is the protein quality of the meal, which otherwise could decrease through reaction with oxidized fish oil.

2.3 Weighing out fish meal into bags

Meal is frequently stored and transported in bags. The manner of weighing the finished meal varies and the degree of automation generally depends upon the processing capacity of the factory. At some fishmeal plants and particularly plants with a processing capacity of less than approximately 60 t of raw fish per 24 h, the bags are weighed and closed using a platform scale. More advanced and automatic methods are generally used in large plants. Stitchers for the bags range from portable sewing machines to large factory floor units. Self closing, valve bags for automatic bags for automatic filling and weighing machines are also used.

Bags: The bags usually hold 50 kg each, and may be open-ended and stitched, or with valves which are tucked in. Bag material ranges from hessian to multi-layer paper (with or without plastic lining), or sheet or woven plastic (low density polyethylene). The hessian bag, made from woven jute, is much used in tropical and sub-tropical countries. The relatively open fabric enables water vapour and heat to escape readily from the meal. The open fabric, however, has a number of disadvantages, such as:

- a. the rapid entry of oxygen from the atmosphere facilitates a high rate of oxidation of residual oil in fish meal not treated with antioxidant. Indeed, the associated heat of reaction may be high enough to cause spontaneous combustion unless the meal is cured (that is allowed to oxidize slowly in single bags or rows of bags) or is protected by means of antioxidant;
- b. the meal is open to rodent and insect infestation and is readily contaminated through bacterial and fungal attacks;
- c. seepage of meal causes loss of product and pollution;
- d. under humid conditions the fish meal absorbs much water and may go mouldy and lumpy.

The paper bag (multi-layer, lined with polyethylene) is widely used by the industry. It keeps out insects and microbes and retards penetration of oxygen and water vapour from the atmosphere. As a result serious temperature increase may be avoided and there is negligible uptake of water vapour during storage.

The (solid sheet) plastic bag offers exceptionally good protection. A large variety of plastic materials (low density polyethylene, PVC, etc.) is now available, and bags may be tailored to suit specific requirements (for example, short- or long-term storage, rough handling, etc.). One of the most important criteria for the quality of plastic packing material is its resistance to penetration of water vapour and oxygen (see Table 2).

Table 2 Passage of oxygen through paper and plastic bags

Material	Temperature (°C)	Area (cm ² x 104)	O ₂ passage NTP (ml /m ² day atm)
Polythene	27	1.196	1 510

Paper 6-ply	23	1.38	18 360
Paper 5-ply	22	1.28	53 200

FIRI Annual Report (1963)

Oxidation and spontaneous heating are reduced to minute proportions only in tucked-in valve bags. If the bags are stitched the stitching holes allow sufficient entry of air to sustain some heating until the meal is cured, especially during handling of the bags. On the other hand, reactive meal in valved bags remains uncured and, if not treated with antioxidant, may be a serious source of spontaneous combustion if bulked immediately after removal from the bags.

Drop testing has indicated that polyethylene bags of 0.25 mm are stronger than multilayer paper bags. Nevertheless, transport and handling frequently result in more serious puncturing damage to polyethylene than to multi-layer paper bags. Also, the filled polyethylene bag is less rigid which, with its relatively low coefficient of friction, tends to make stowage more difficult and may more easily result in slipping and displacement during transport.

Palletizing: Wooden pallets holding about 1.5 t (30 bags) are often used to facilitate handling and stacking of bags after manufacture. Pallets may be stacked three high with fork lift trucks, after the meal has cooled to room temperature.

2.4 Cooling

Whether the freshly prepared fish meal is stabilized with ethoxyquin or not, it must be cooled to room temperature before it is stored in bulk. Bags of stabilized fish meal are left standing for a few days in single or double rows, or on singly-spaced pallets. Unbagged fish meal should be cooled by an air current or continually turned till cool. This can be done either in properly designed silos as, for example, in Norway and Denmark, or by turning the heaps of fish meal by means of bulldozers or conveyors as, for example, in the USA. Unstabilized reactive fish meal should be "cured" for 28 days, that is regularly turned if unbagged, or in small units if bagged, before stacking in bulk. For the first few days the bags should be placed on the floor apart from each other, or in single rows, depending on the initial reactivity of the meal; thereafter they may be stacked in double rows for the remaining 28-day period. Handling and storage on the floor involves a certain risk of Salmonella contamination.

2.5 Pelletizing

Pelletized fish meal, mainly produced by large manufacturers, facilitates bulk storage and transport. The flow properties are improved and dusting is reduced. Pellets do not represent any essential space saving compared with bulk stored meal; nor are oxidation and spontaneous heating retarded by pelletizing. The bulk density of pellets is the same as that of fish meal (generally 600 to 700 kg/m³). During handling, however, some of the pellets break and the broken pieces and meal formed in this way occupy the spaces between the pellets and thus increase the bulk density. Pellet diameters vary between 8 mm and 12 mm. Pelleting machines of 120 hp are capable of turning out about 5 t of pellets or more per hour.

Figure 19 illustrates the principle of the pellet press: (a) is the press mould (matrix), (b) the press rollers, (c) the distributor, (d) the knife, and (e) the pellets. The rollers press the meal

through the holes of the matrix, and the knife cuts the pellets to the desired length. Usually, steam or hot stickwater concentrate is added to facilitate the formation of firm pellets. The pellets are usually made from hot meal emerging from the dryer and are cooled with fresh air in a cooling tower.

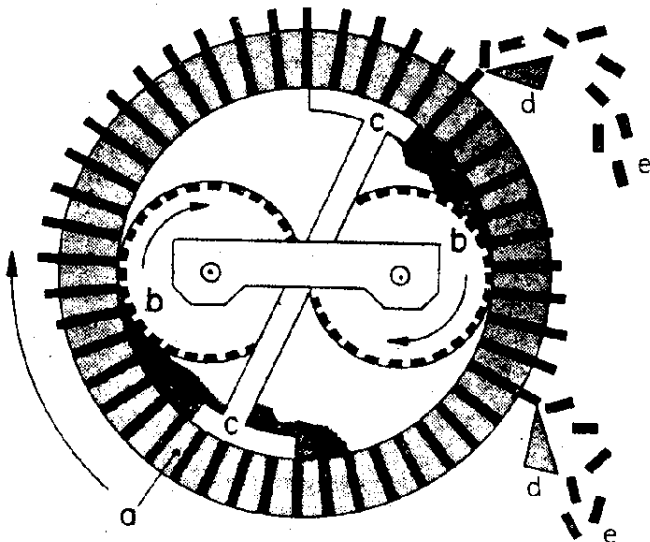

Figure 19 Pellet press

2.6 Storage

Storage methods for fish meal vary, depending upon many factors, including climatic conditions, production capacity, use of antioxidant and transport and marketing arrangements. Factories should have storage capacity for a reasonable buffer stock. In case of difficult marketing and shipping conditions, large storage capacities, for instance, sufficient to hold 30 days' production, may be required.

Fish meal must be protected from moisture and fishmeal stores must therefore be moisture proof. If necessary, the inner surface of the roof should be insulated or the stores provided with ceilings to avoid condensation and drip at night, with consequent localized mould growth and lumping in the fish meal. Only in arid regions may fish meal be stored out in the open. Fish meal must also be protected from undue self heating, whether it is treated with antioxidant or stored after curing. For this reason, bulk storage units should not exceed about 5 m in width.

Many different stacking arrangements for cooled bags are available from IAFMM. These arrangements are designed to limit the dimensions of the stacks, or to provide channels or "chimneys" through the stacks to carry away the small amount of residual heat generated. In this way, undue internal temperature rise is avoided and moisture migration from warm to cooler areas inhibited. Moisture migration can result in condensation, mould growth and lumping. Mould growth (as distinct from bacterial growth) may lead to spontaneous heating up to about 40°C at which temperature the moulds are destroyed; but at this elevated temperature spontaneous heating through oxidation of the oil may be accelerated, unless the fish meal is properly cured or stabilized with antioxidant.

Shipping stowage recommendations, also available from IAFMM, provide for athwartship twin columns of bags with 15 to 20 cm gaps between each tier, with cross dunnage.

Bulk storage: It is estimated that about half of the world's fish meal is stored in bulk in sheds and silos. Major manufacturers are taking an increasing interest in bulk storage because:

- a. all handling, from production to loading on transport vessels, becomes simpler, cheaper and results in a considerable saving in manpower used in maintenance, filling, weight control and stowage of bags;
- b. transport vessels and international receiving centres are being more and more geared to bulk handling, so that bulk storage in the factory is more compatible with modern overall handling systems.

In general, facilities for bulk storage are either of the open type (access of air through doors and other openings) or of the sealed type (space sealed off from the surroundings, as in special silos). The open type predominates in the fishmeal industry, and the ready availability of oxygen causes lipid oxidation of freshly made reactive meal not treated with antioxidant to proceed relatively rapidly. In order to dissipate the heat of reaction, the meal requires frequent aeration. This is particularly important during the initial storage stage when it is most reactive. A suitable practice of aeration involves conveying the meal from one storage space to another. If suitable antioxidant, however, is admixed with the meal, the latter is stabilized and considerably less aeration is required; indeed, only that which is necessary to cool the meal to room temperature. In open storage, special care should be given to pest and rodent control to prevent infection, for example by Salmonella.

The facilities in use for bulk storage of fish meal are the same as those employed in granaries, except for some modifications due to the "compacting" properties of the meal. The two most generally used systems are sheds, divided into several compartments, and silos.

Storage sheds may be of single or multistoried construction. Owing to the weight and the pressures exerted on the walls, such sheds are usually of single floor construction. Multistorage sheds should preferably be of concrete construction throughout, particularly the floors and outer walls.

Silos have found use in the fishmeal industry in recent years, not only because they offer good protection to meal during storage, but also because they increase flexibility in handling. This is perhaps the most important advantage of the silo over other types of storage facility.

Fish meal that is stored in specially designed silos may be kept in motion by continuously extracting it from the bottom and returning it to the top by means of automatic conveyor mechanisms. In this way, the meal is aerated for cooling and curing, and is also blended. It is also prevented from compacting and bridging. Generally, fish meal does not flow readily and tends to compact under pressure, especially at elevated temperature. The silos need special construction because of the relatively poor flow property of fish meal. Cylindrical silos are often preferred, but silos with square or rectangular cross-section are also satisfactory. The ease of discharge depends on the meal's physical properties and in particular on particle size distribution, especially fines content, moisture and fat contents, amount of solubles added, etc., and bridging is best prevented by assuring sufficient ventilation and circulation of meal during storage. The flow properties of fish meal can be improved by reducing the moisture content to 7% or by pelletizing.

The point of discharge at the bottom is the most critical part of the silo and is preferably constructed of steel. Depending on the cross-section of the silo, there may be several points of discharge.

The conical discharge section of cylindrical silos should have a slope at least 10° greater than the meal's angle of repose, which is of the order of 45° . Discharge chutes from corners of square silos are generally wedge-shaped, with three sides vertical and the fourth at an angle. A number of silos are normally arranged in one or more rows, which may take the form of a compact block. The multi-row arrangement is general for square silos since one silo will have walls in common with others, a saving in investment.

Blending silos constitute an integral part of the production and storage system. They are generally smaller than storage silos, and emphasis is placed on the efficiency and rate of their discharge and recirculation mechanisms to handle one to three days of peak fishmeal production. During blending, meals of various qualities are homogenized. This results in an overall quality increase because of:

- a. uniformity of the main constituents, protein, fat and water;
- b. more even grain size, which makes mixing of the meal into animal diets easier, and
- c. uniformity of colour, which improves the meal's market appeal.

Fish oil is stored in conventional tanks made from mild steel. The following design features are usually included:

- a. separation of residual water from the oil during storage necessitates water drainage at the tank bottom;
- b. in cold climates, the tanks must be equipped with steam-heated coils to keep the oil fluid during discharge;
- c. to facilitate good setting oil storage tanks are preferably insulated;
- d. to prevent contamination by sludge and water, unloading should be from a tube situated some way above the bottom of the tank.