

Digital Modulation

Change which part of the Carrier?

Carrier: $A \sin[\omega t + \varphi]$

- $A = \text{const}$
- $\omega = \text{const}$
- $\varphi = \text{const}$

◆ Amplitude modulation (AM)

- $A = A(t)$ – carries information
- $\omega = \text{const}$
- $\varphi = \text{const}$

◆ Frequency modulation (FM)

- $A = \text{const}$
- $\omega = \omega(t)$ – carries information
- $\varphi = \text{const}$

◆ Phase modulation (PM)

- $A = \text{const}$
- $\omega = \text{const}$
- $\varphi = \varphi(t)$ – carries information

Amplitude Shift Keying (ASK)

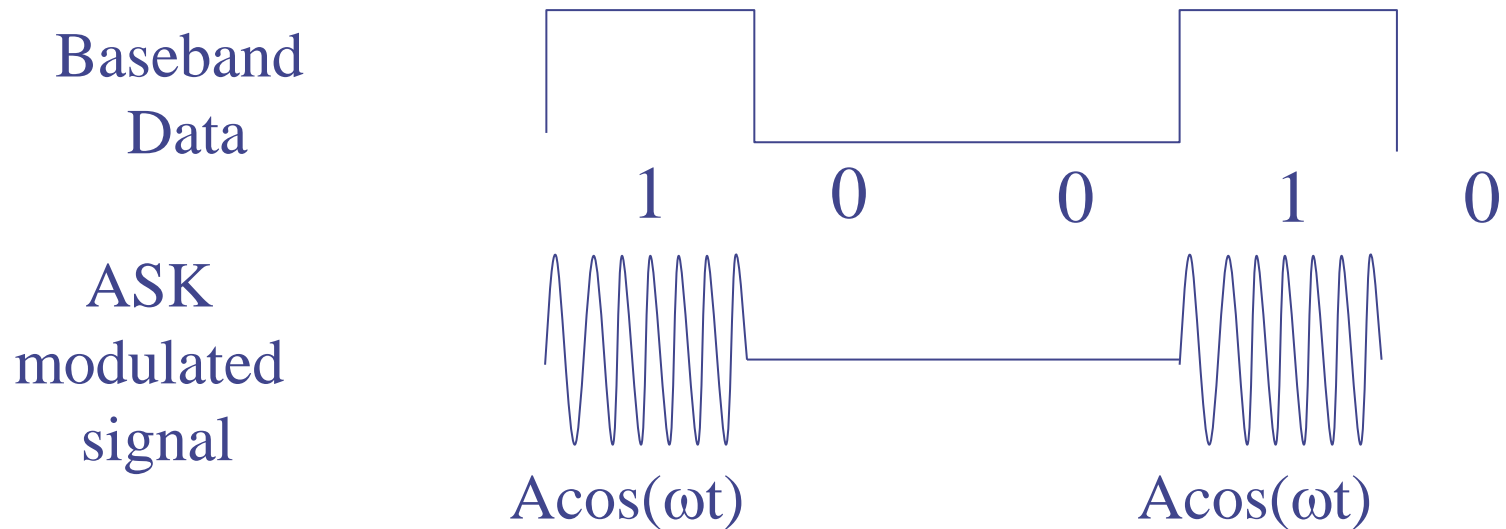

- ◆ Pulse shaping can be employed to remove spectral spreading
- ◆ ASK demonstrates poor performance, as it is heavily affected by noise, fading, and interference

Frequency Shift Keying (FSK)

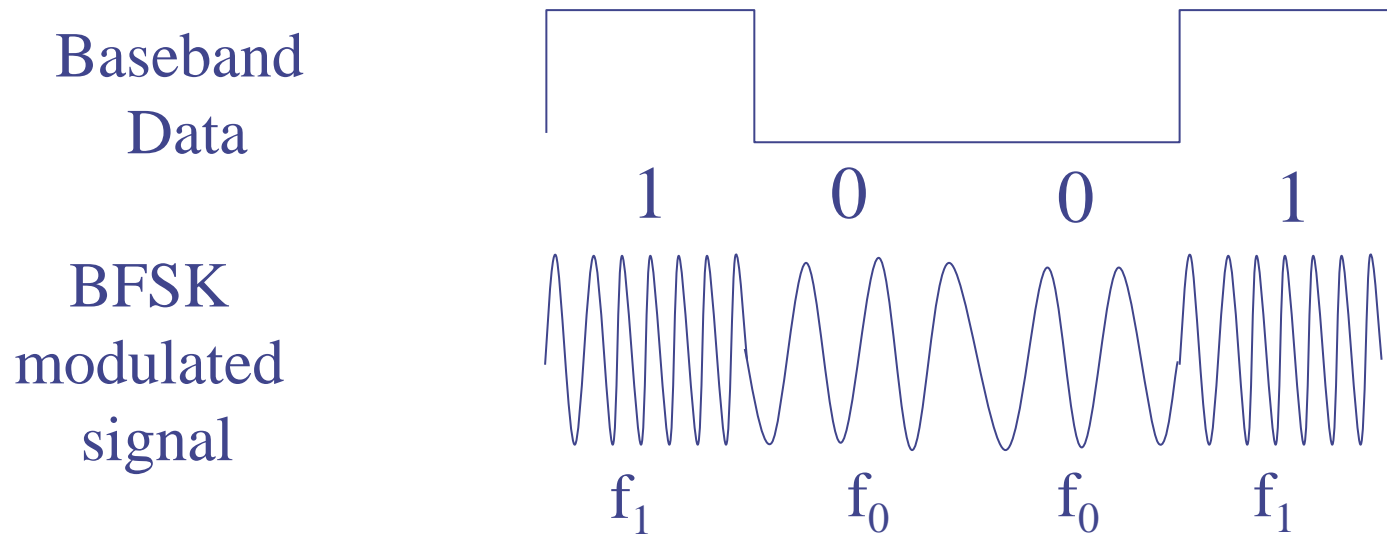

where $f_0 = A \cos(\omega_c - \Delta\omega)t$ and $f_1 = A \cos(\omega_c + \Delta\omega)t$

Example: The ITU-T V.21 modem standard uses FSK

FSK can be expanded to a M-ary scheme, employing multiple frequencies as different states

Phase Shift Keying (PSK)

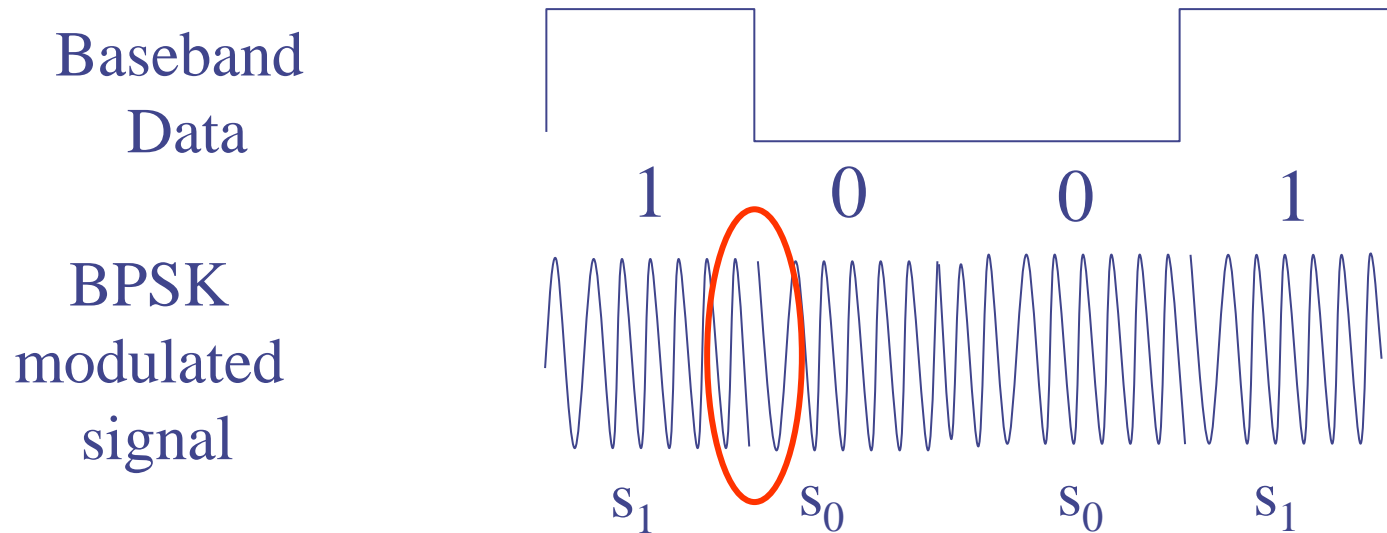

where $s_0 = -A\cos(\omega_c t)$ and $s_1 = A\cos(\omega_c t)$

Major drawback – rapid amplitude change between symbols due to phase discontinuity, which requires infinite bandwidth. Binary Phase Shift Keying (BPSK) demonstrates better performance than ASK and BFSK
BPSK can be expanded to a M-ary scheme, employing multiple phases and amplitudes as different states

Binary **Phase Shift Keying (BPSK)**

If the sinusoidal carrier has an amplitude A_c and energy per bit E_b

Then the transmitted BPSK signal is either:

$$S_{\text{BPSK}}(t) = \sqrt{\frac{2E_b}{T_b}} \cos(2\pi f_c t + \theta_c) \quad 0 \leq t \leq T_b \text{ (binary 1)}$$

$$\begin{aligned} S_{\text{BPSK}}(t) &= \sqrt{\frac{2E_b}{T_b}} \cos(2\pi f_c t + \pi + \theta_c) \\ &= -\sqrt{\frac{2E_b}{T_b}} \cos(2\pi f_c t + \theta_c) \quad 0 \leq t \leq T_b \text{ (binary 0)} \end{aligned}$$

Linear Modulation Techniques:

Digital modulation can be broadly classified as:

1. Linear (change Amplitude or phase)
2. Non linear modulation techniques (change frequency).

Linear Modulation Techniques:

- The **amplitude /phase** of the transmitted signal $s(t)$, varies linearly with the modulating digital signal, $m(t)$.
- These are **bandwidth efficient (because it doesn't change frequency)** and hence are very attractive for use in wireless communication systems where there is an increasing demand to accommodate more and more users within a limited spectrum.

Pros & Cons

- Linear Modulation schemes have very **good spectral efficiency**,
- However, they must be transmitted using **linear RF amplifiers** which have **poor power efficiency**.

Note

- ◆ “Phase modulation” can be regarded as “amplitude” modulation because it can really change “envelope”;
- ◆ Thus both of them belong to “linear modulation”!

Differential Modulation

- ◆ In the transmitter, each symbol is modulated relative to the previous symbol and modulating signal, for instance in BPSK $0 = \text{no change}$, $1 = +180^\circ$
- ◆ In the receiver, the current symbol is demodulated using the previous symbol as a reference. The previous symbol serves as an estimate of the channel. A no-change condition causes the modulated signal to remain at the same 0 or 1 state of the previous symbol.

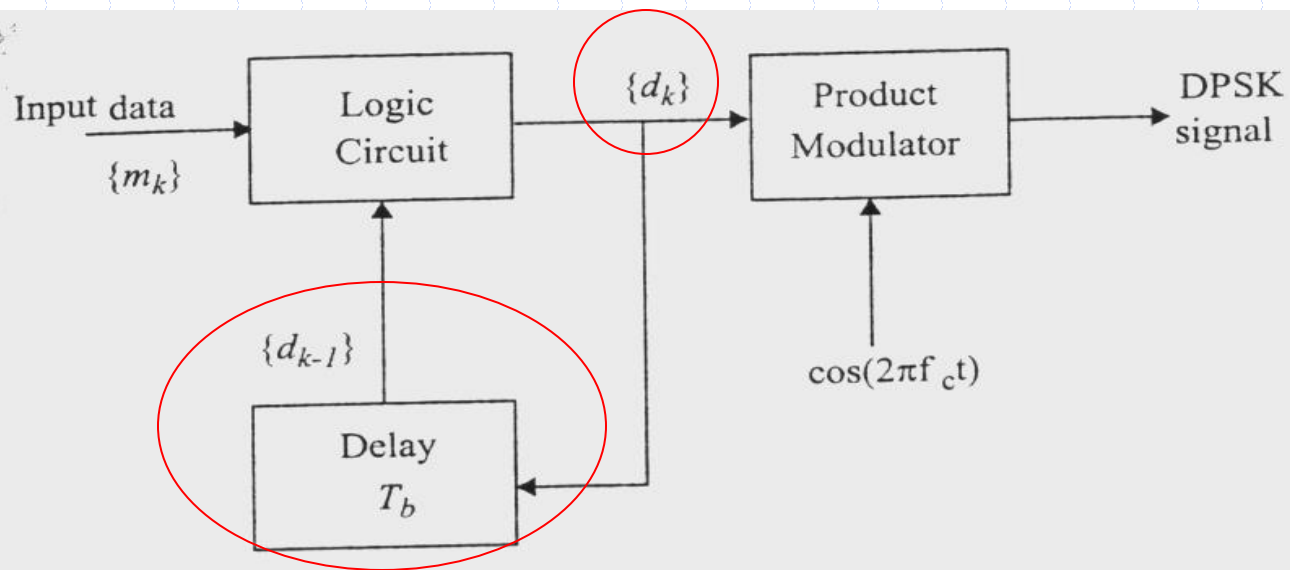

Figure 5.24
Block diagram of a DPSK transmitter.

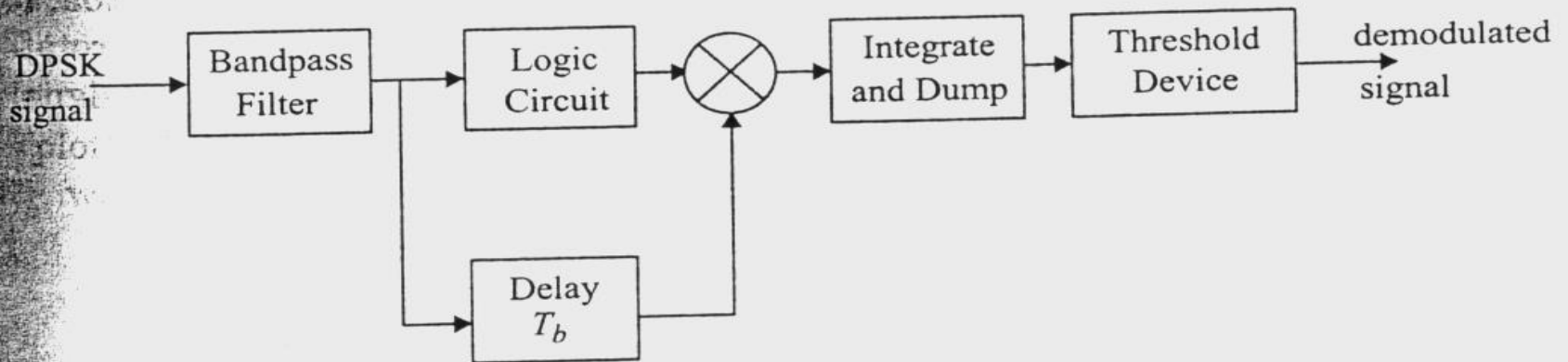

Figure 5.25
Block diagram of DPSK receiver.

Table 5.1 Illustration of the Differential Encoding Process

$\{m_k\}$		1	0	0	1	0	1	1	0
$\{d_{k-1}\}$		1	1	0	1	1	0	0	0
$\{d_k\}$	1	1	0	1	1	0	0	0	1

DPSK

Let $\{d_k\}$ denote the differentially encoded sequence with this added reference bit. We now introduce the following definitions in the generation of this sequence:

- If the incoming binary symbol b_k is **1**, leave the symbol d_k **unchanged** with respect to the previous bit.
- If the incoming binary symbol b_k is **0**, **change** the symbol d_k with respect to the previous bit.

DPSK

- to send symbol 0, we advance the phase of the current signal waveform by 180 degrees,
- to send symbol 1, we leave the phase of the current signal waveform unchanged.

Generation of DPSK:

- The differential encoding process at the transmitter input starts with an arbitrary first bit, serving as reference.

Differential Phase Shift Keying (DPSK):

- DPSK is a **non coherent** form of phase shift keying which avoids the need for a coherent reference signal at the receiver.

Advantage:

- Non coherent receivers are **easy and cheap to build**, hence widely used in wireless communications.
- DPSK eliminates the need for a coherent reference signal at the receiver by combining two basic operations at the transmitter:

Pulse Carrier

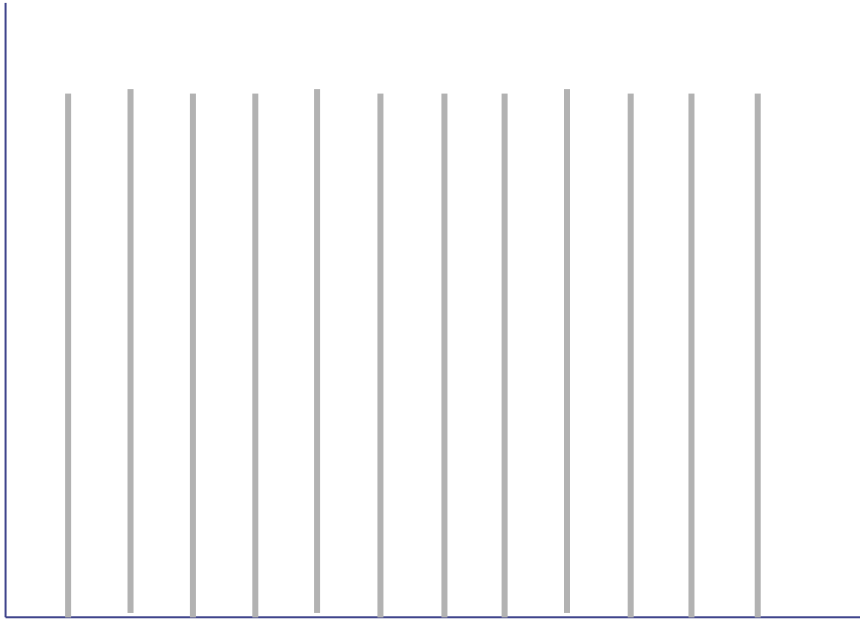

- ◆ Carrier:
A train of identical pulses regularly spaced in time

Pulse-Amplitude Modulation (PAM)

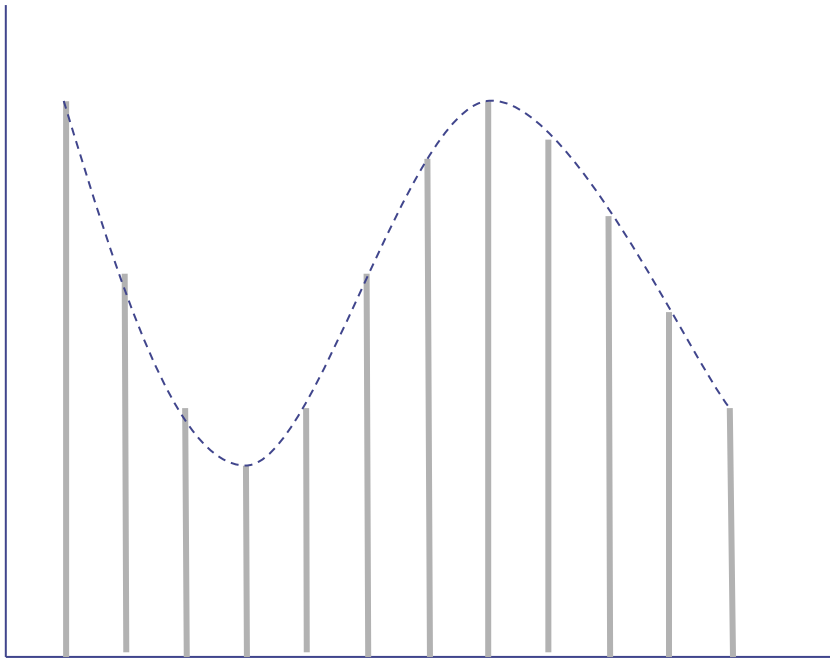

- ◆ Modulation in which the amplitude of pulses is varied in accordance with the modulating signal.
- ◆ Used e.g. in telephone switching equipment such as a private branch exchange (PBX)

Pulse-Duration Modulation (PDM)

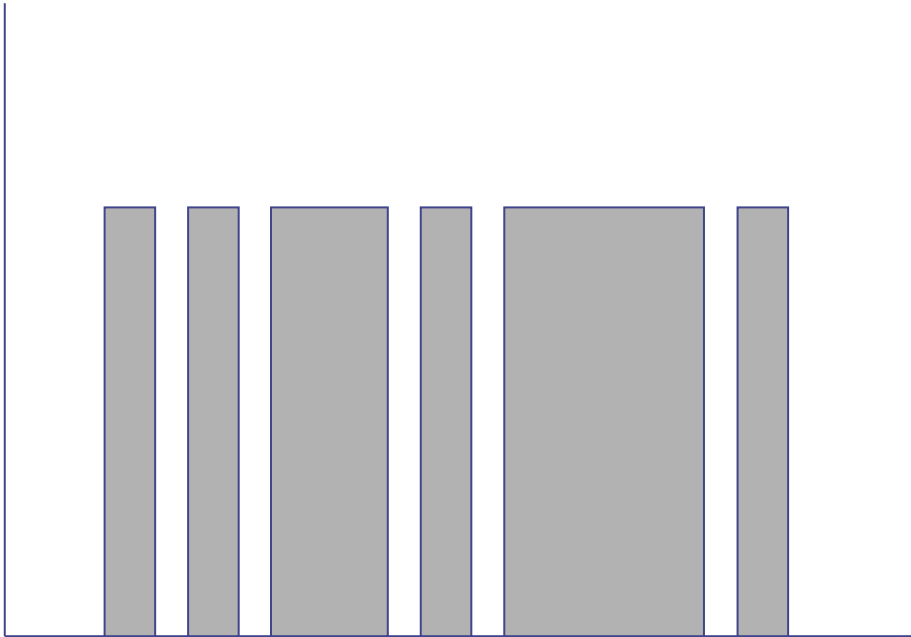

Used e.g. in telephone switching equipment such as a private branch exchange (PBX)

Modulation in which **the duration of pulses** is varied in accordance with the modulating signal.

Deprecated synonyms:
pulse-length modulation,
pulse-width modulation.

Demodulation & Detection

◆ Demodulation

- Is process of removing the carrier signal to obtain the original signal waveform

◆ Detection – extracts the symbols from the waveform

- Coherent detection
- Non-coherent detection

Coherent Detection

- ◆ An estimate of the channel phase and attenuation is recovered. It is then possible to reproduce the transmitted signal and demodulate.
- ◆ Requires a **replica carrier wave** of the same frequency and phase at the receiver.
- ◆ Also known as synchronous detection (I.e. carrier recovery)

Coherent Detection 2

◆ Carrier recovery methods include

- Pilot Tone (such as Transparent Tone in Band)
 - ◆ Less power in the information bearing signal, High peak-to-mean power ratio
- Carrier recovery from the information signal
 - ◆ E.g. Costas loop

◆ Applicable to

- Phase Shift Keying (PSK)
- Frequency Shift Keying (FSK)
- Amplitude Shift Keying (ASK)

Non-Coherent Detection

- ◆ Requires no reference wave; does not exploit phase reference information (envelope detection)
 - Differential Phase Shift Keying (DPSK)
 - Frequency Shift Keying (FSK)
 - Amplitude Shift Keying (ASK)
- Non coherent detection is less complex than coherent detection (easier to implement), but has worse performance.

QPSK

- ◆ Quadrature Phase Shift Keying (QPSK) can be interpreted as two independent BPSK systems (one on the I-channel and one on Q-channel), and thus the same performance but twice the bandwidth (spectrum) efficiency.

QPSK Constellation Diagram

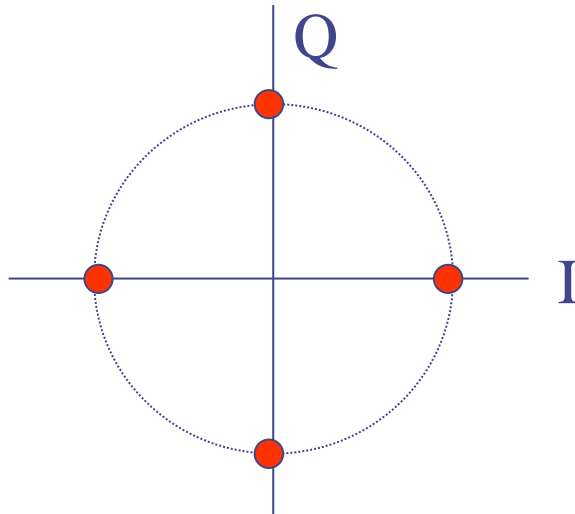

Carrier phases
 $\{0, \pi/2, \pi, 3\pi/2\}$

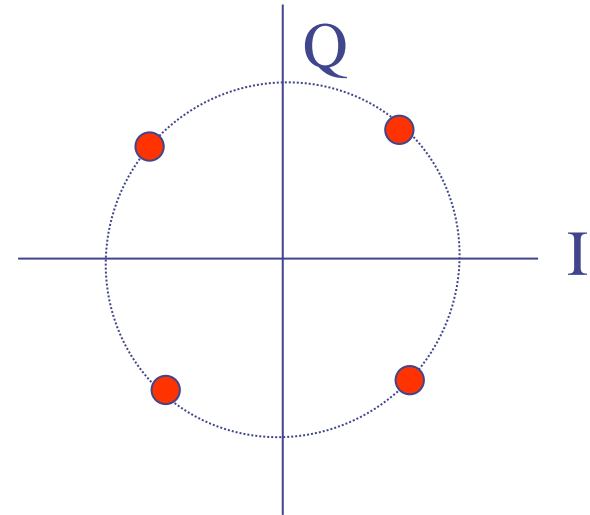

Carrier phases
 $\{\pi/4, 3\pi/4, 5\pi/4, 7\pi/4\}$

- ◆ Quadrature Phase Shift Keying has **twice the bandwidth efficiency of BPSK** since 2 bits are transmitted in a single modulation symbol

Types of QPSK

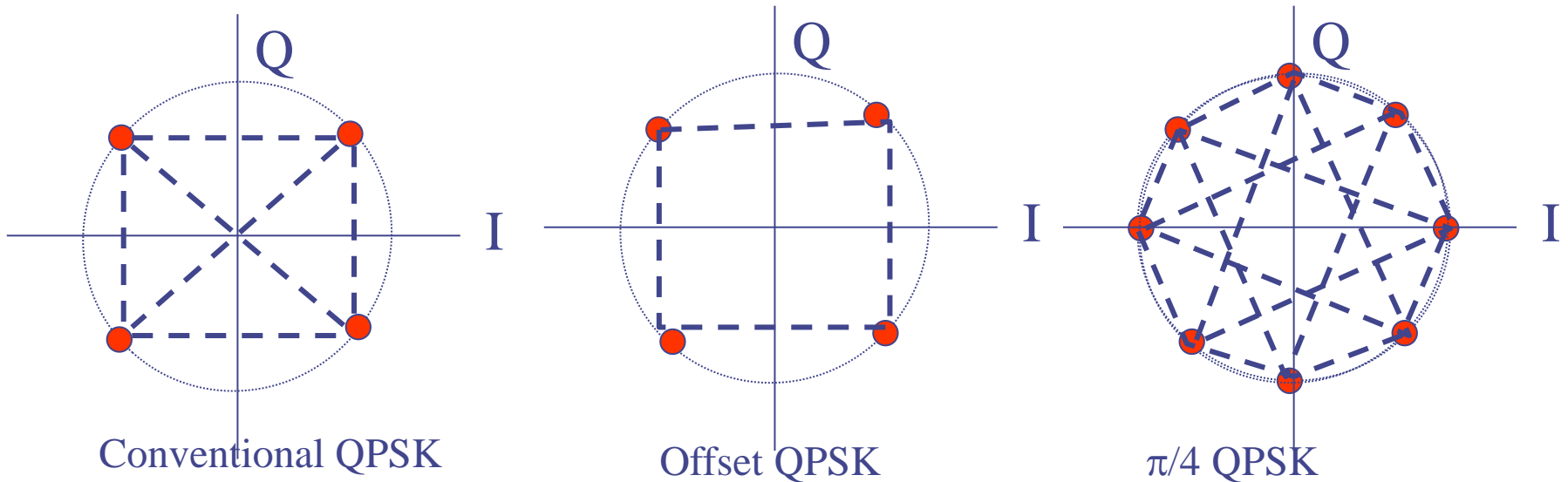

- ◆ **Conventional QPSK** has transitions **through zero** (i.e. 180° phase transition). Highly linear amplifiers required.
- ◆ **In Offset QPSK**, the phase transitions are limited to 90° , the transitions on the I and Q channels are staggered.
- ◆ **In $\pi/4$ QPSK** the set of constellation points are toggled each symbol, so transitions through zero cannot occur. This scheme produces **the lowest envelope variations**.
- ◆ **All QPSK schemes** require linear power amplifiers

Quadrature Phase Shift Keying (QPSK):

- Also a type of linear modulation scheme
- Quadrature Phase Shift Keying (QPSK) has twice the bandwidth efficiency of BPSK, since **2 bits are transmitted in a single modulation symbol**.
- The phase of the carrier takes on 1 of 4 equally spaced values, $0, \pi/2, \pi,$ and $3\pi/2,$ where each value of phase corresponds to a unique pair of message bits.
- The QPSK signal for this set of symbol states may be

$$S_{\text{QPSK}}(t) = \sqrt{\frac{2E_s}{T_s}} \cos \left[2\pi f_c t + (i-1) \frac{\pi}{2} \right] \quad 0 \leq t \leq T_s \quad i = 1, 2, 3, 4.$$

QPSK

$$S_{\text{QPSK}} = \{ \sqrt{E_s} \cos \left[(i-1) \frac{\pi}{2} \right] \phi_1(t) - \sqrt{E_s} \sin \left[(i-1) \frac{\pi}{2} \right] \phi_2(t) \} \quad i = 1, 2, 3, 4$$

- The striking result is that the bit error probability of QPSK is identical to BPSK, but twice as much data can be sent in the same bandwidth. **Thus, when compared to BPSK, QPSK provides twice the spectral efficiency with exactly the same energy efficiency.**
- Similar to BPSK, QPSK can also be differentially encoded to allow non-coherent detection.

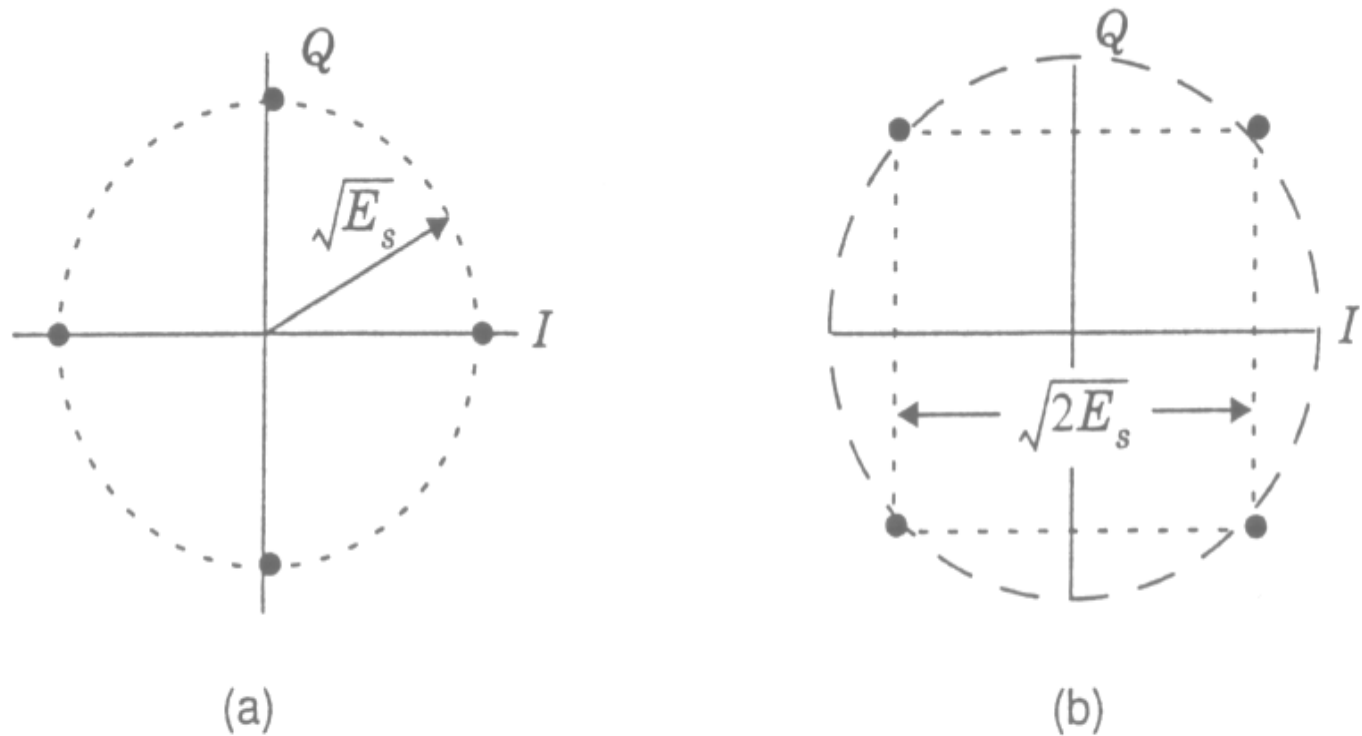
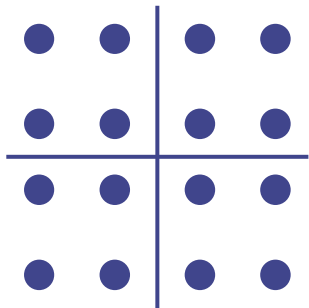

Figure 5.26

(a) QPSK constellation where the carrier phases are $0, \pi/2, \pi, 3\pi/2$.

(b) QPSK constellation where the carrier phases are $\pi/4, 3\pi/4, 5\pi/4, 7\pi/4$.

Multi-level (M-ary) Phase and Amplitude Modulation



16 QAM

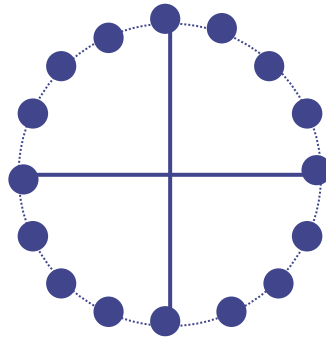

16 PSK

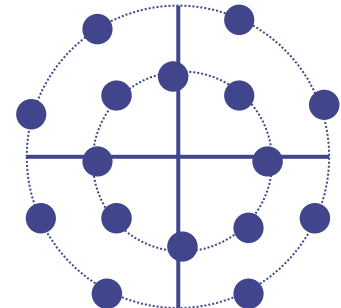

16 APSK

- ◆ **Amplitude and phase shift keying** can be combined to transmit several bits per symbol.
 - Often referred to as *linear* as they require linear amplification.
 - More bandwidth-efficient, but more susceptible to noise.
- ◆ For $M=4$, **16QAM has the largest distance between points**, but requires **very linear amplification**. **16PSK** has less stringent linearity requirements, but has **less spacing between constellation points**, and is therefore more affected by noise.

Distortions

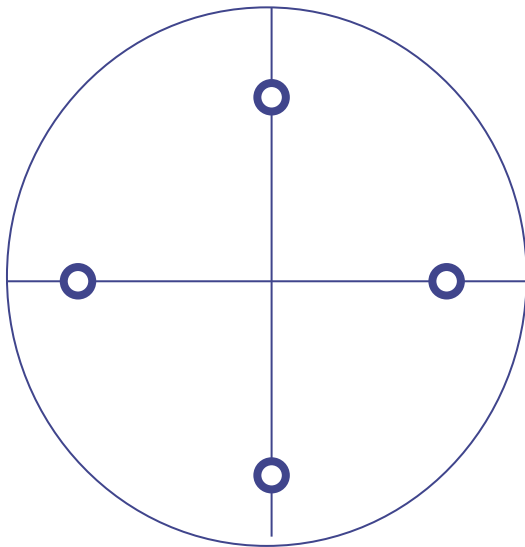

Perfect channel

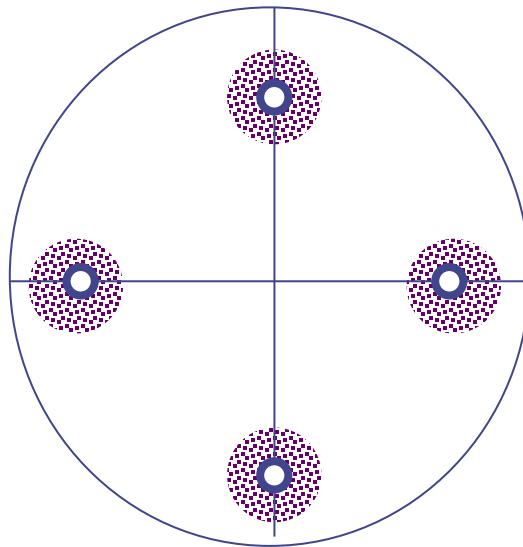

White noise

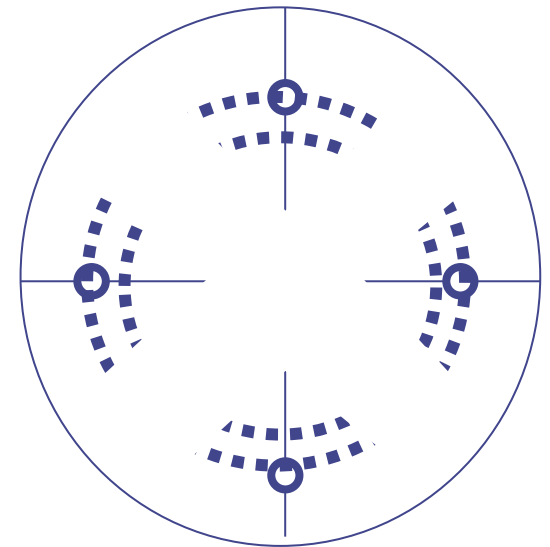

Phase jitter

Bandwidth Efficiency

$$\frac{f_b}{W} = \log_2 \left(1 + \frac{E_b f_b}{\eta W} \right)$$

f_b = capacity (bits per second)

W = bandwidth of the modulating baseband signal (Hz)

E_b = energy per bit

η = noise power density (watts/Hz)

Thus

$E_b f_b$ = total signal power

ηW = total noise power

$\frac{f_b}{W}$ = bandwidth use efficiency

= bits per second per Hz

Comparison of Modulation Types

Modulation Format	Bandwidth efficiency C/B	Log ₂ (C/B)	Error-free Eb/N ₀
16 PSK	4	2	18dB
16 QAM	4	2	15dB
8 PSK	3	1.6	14.5dB
4 PSK	2	1	10dB
4 QAM	2	1	10dB
BFSK	1	0	13dB
BPSK	1	0	10.5dB

Spectral Efficiencies - Examples

◆ GSM Europe Digital Cellular

- Data Rate = 270kb/s; Bandwidth = 200kHz
- Bandwidth efficiency = $270/200 = 1.35$ bits/sec/Hz

◆ IS-95 North American Digital Cellular

- Data Rate = 48kb/s; Bandwidth = 30kHz
- Bandwidth efficiency = $48/30 = 1.6$ bits/sec/Hz

BFSK Transmitter

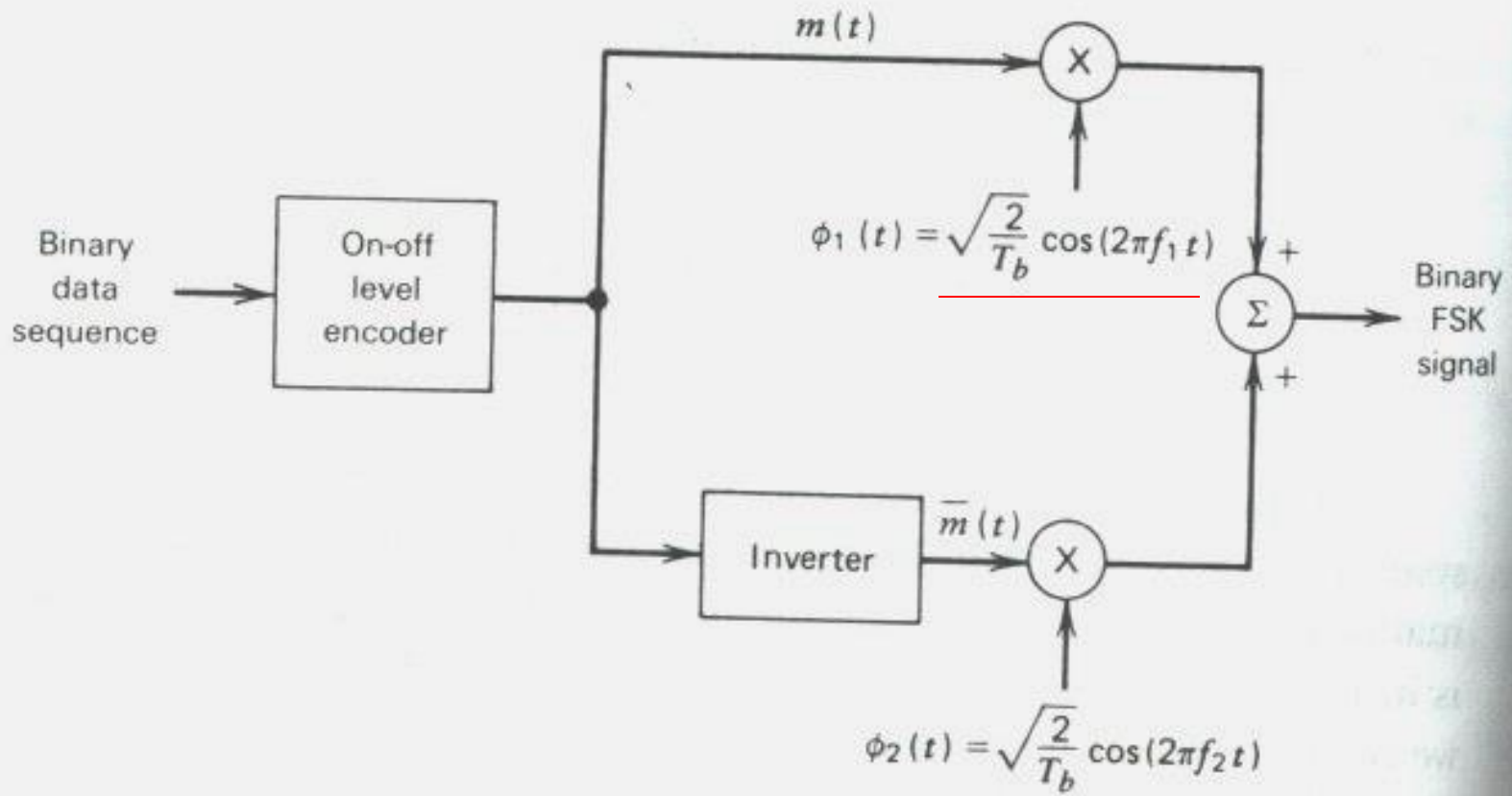

Coherent Detection Of BFSK

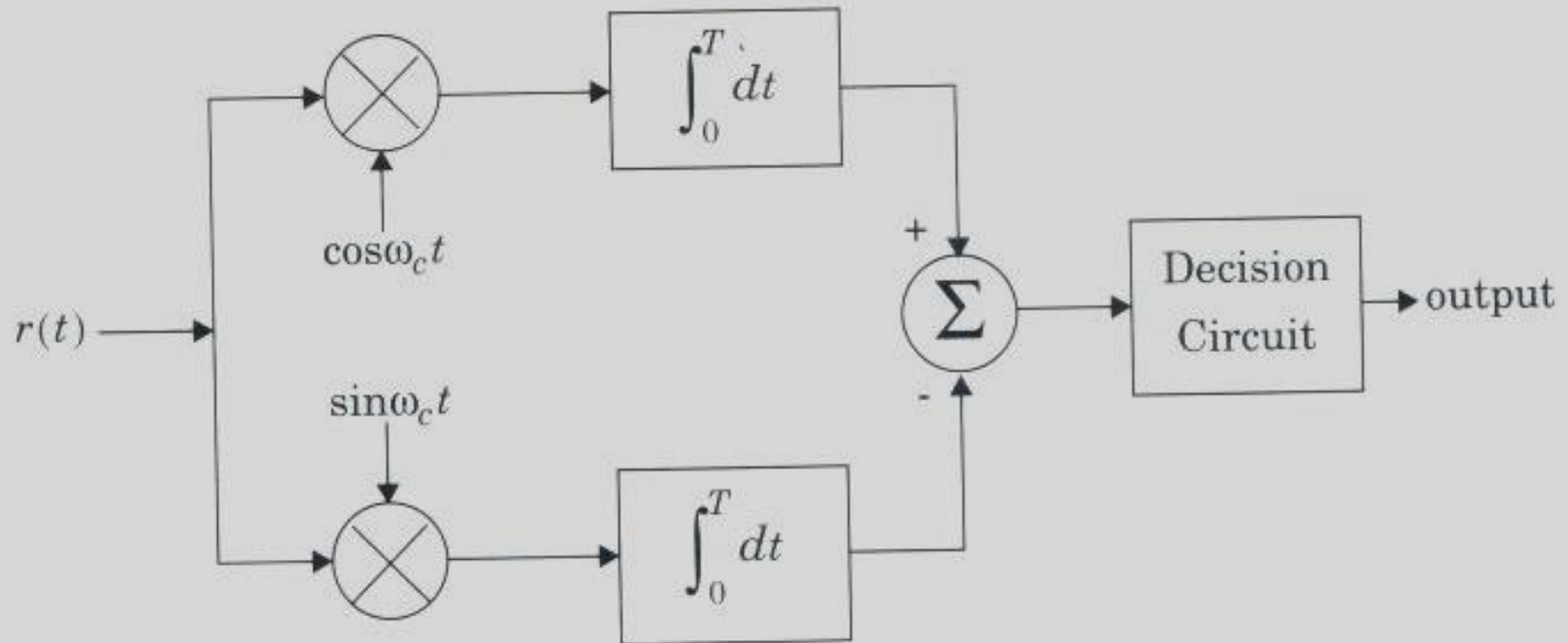

FSK Spectrum

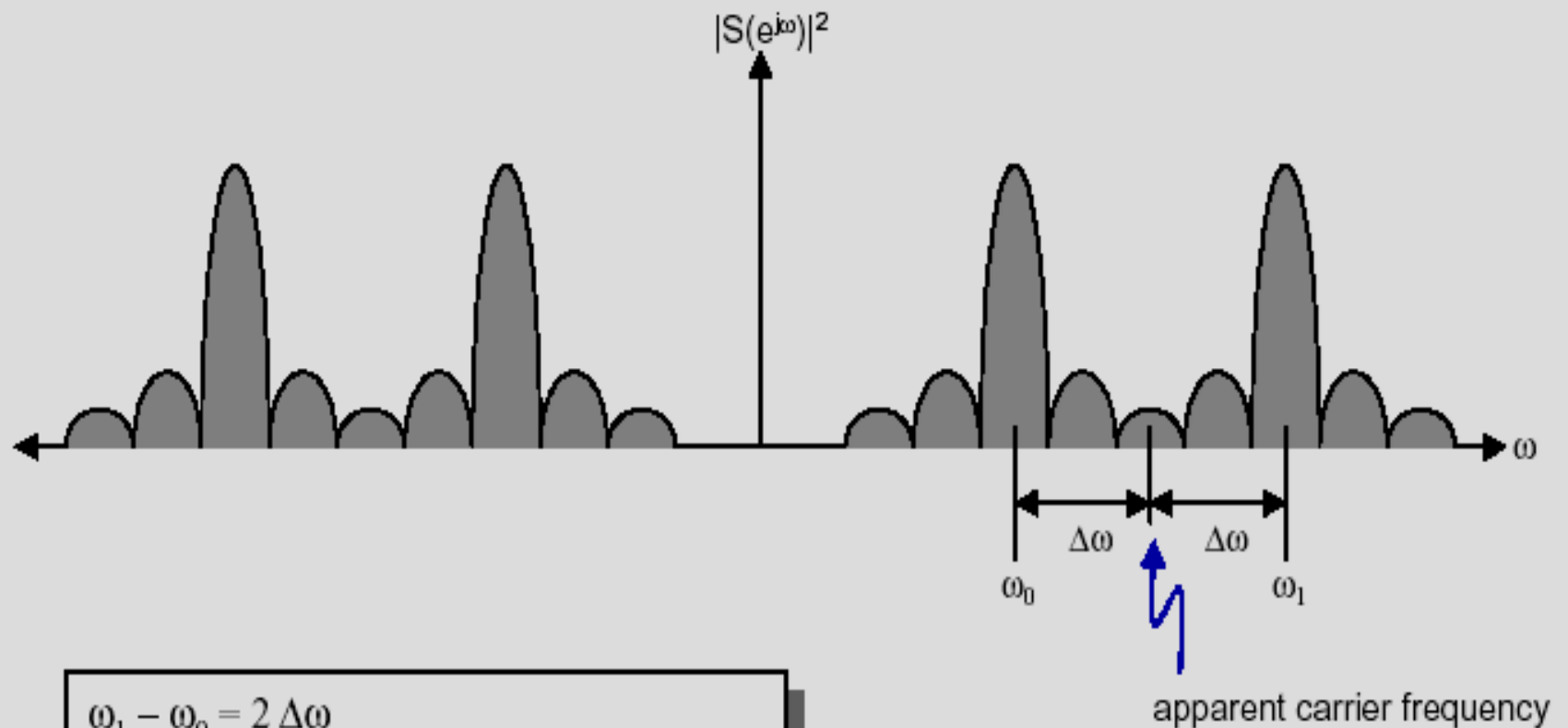

Minimum Shift Keying (MSK)

MSK is a continuous **phase-frequency** shift keying;

Why MSK?

-- Exploitation of **Phase** Information **besides frequency**.

Representation of a MSK signal

$$s(t) = s_1\phi_1(t) + s_2\phi_2(t) \quad 0 \leq t \leq T_b$$

the appropriate form for the orthonormal basis functions $\phi_1(t)$ and $\phi_2(t)$ is as follows:

$$\phi_1(t) = \sqrt{\frac{2}{T_b}} \cos\left(\frac{\pi}{2T_b} t\right) \cos(2\pi f_c t) \quad -T_b \leq t \leq T_b \quad (7.59)$$

and

$$\phi_2(t) = \sqrt{\frac{2}{T_b}} \sin\left(\frac{\pi}{2T_b} t\right) \sin(2\pi f_c t) \quad 0 \leq t \leq 2T_b \quad (7.60)$$

Input binary sequence

1 1 0 1 0 0 0

time scale



(a)

$\theta(kT_b)$
Polarity of s_1

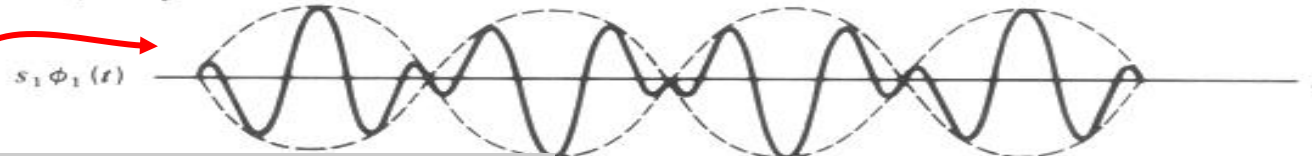

(b)

$$s(t) = s_1 \phi_1(t) + s_2 \phi_2(t) \quad 0 \leq t \leq T_b$$

$\theta(kT_b)$
Polarity of s_2

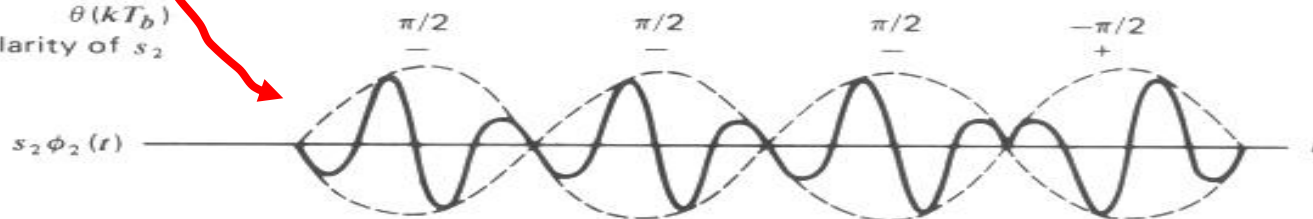

(c)

$s(t)$

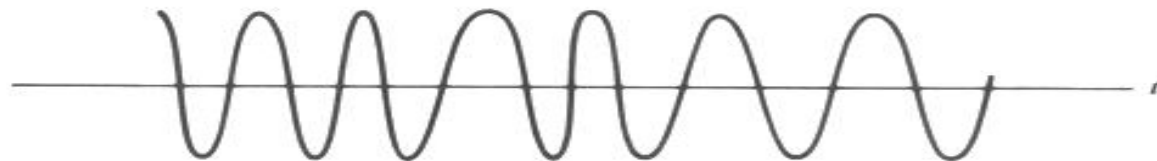

(d)

Figure 7.13 Sequence and waveforms for MSK signal. (a) Input binary sequence. (b) Scaled time function $s_1\phi_1(t)$. (c) Scaled time function $s_2\phi_2(t)$. (d) MSK signal $s(t)$ obtained by adding $s_1\phi_1(t)$ and $s_2\phi_2(t)$ on a bit-by-bit basis.

MSK Transmitter

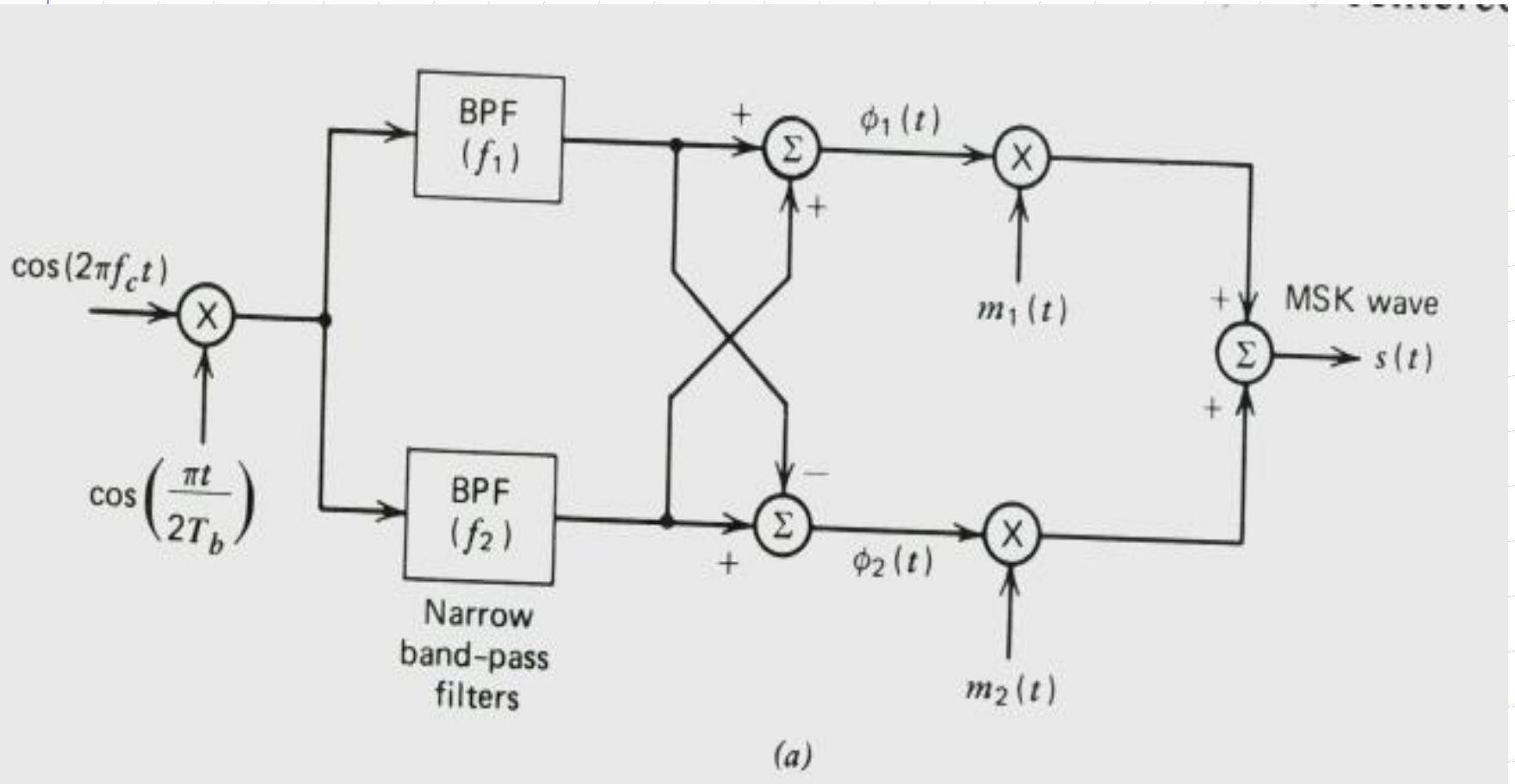

MSK Receiver

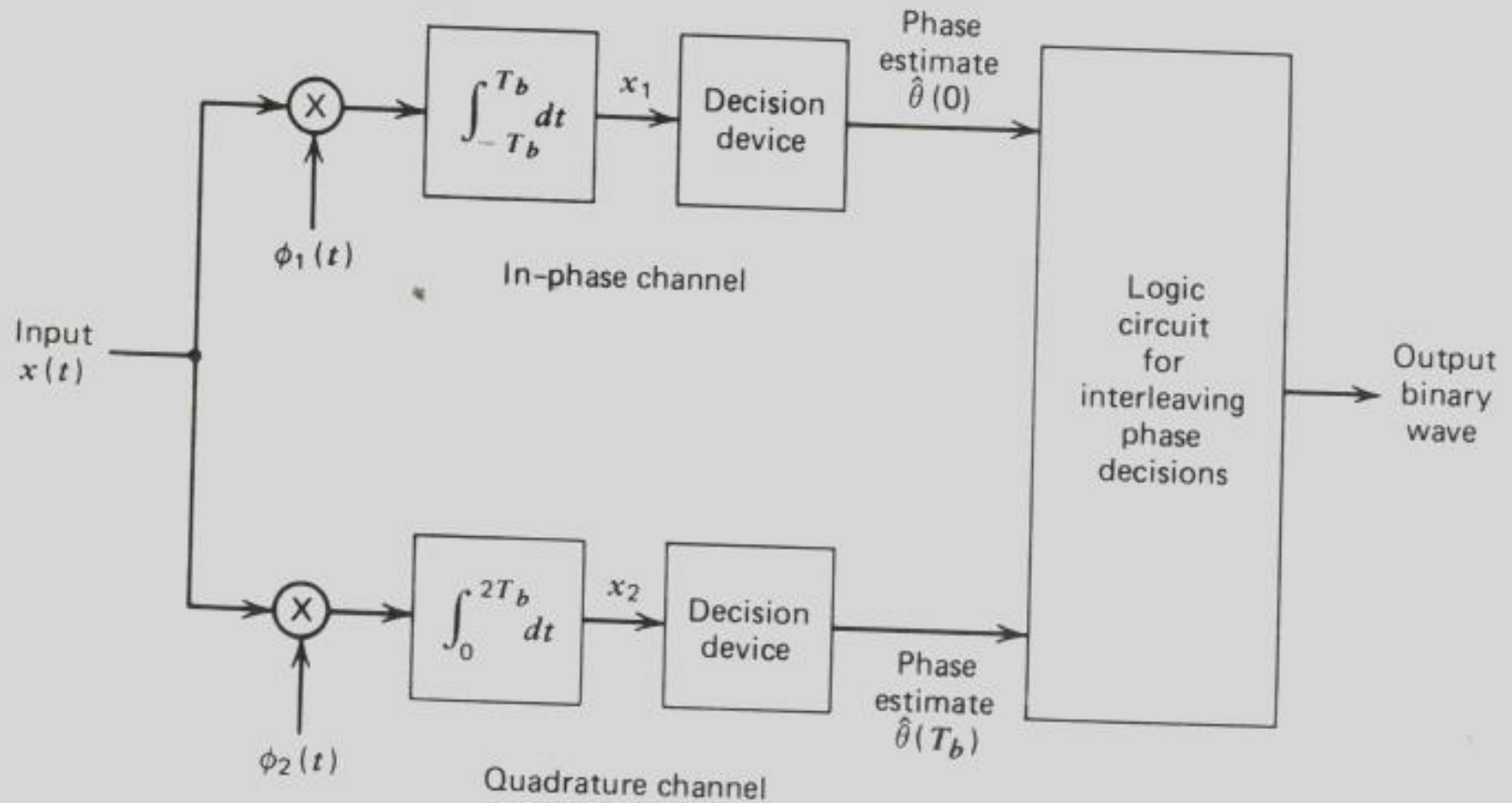



M-ary

Combined Linear and nonlinear (Constant Envelope)
Modulation Techniques

Topics :

- ◆ What is M-ary modulation?
- ◆ Various M-ary modulation Techniques:
 - M-ary Phase Shift Keying (MPSK)
 - M-ary Quadrature Amplitude Modulation (QAM)
 - M-ary Frequency Shift Keying (MFSK)

⑩ Definition:

In this modulation Technique the digital data is sent by varying both the **envelope and phase(or frequency) of an RF carrier**.

These modulation techniques map base band data into **four or more possible RF carrier signals**. Hence, these modulation techniques are called **M-ary modulation**.

M-ary signaling scheme:

- In this signaling scheme 2 or more bits are grouped together to form a symbol.
- One of the M possible signals $s_1(t), s_2(t), s_3(t), \dots, s_M(t)$ is transmitted during each symbol period of duration T_s .
- The number of possible signals = $M = 2^n$, where n is an integer.

The symbol values of M for a given value of n:

n	$M = 2^n$	Symbol
1	2	0, 1
2	4	00, 01, 10, 11
3	8	000, 001, 010, 011, ...
4	16	0000, 0001, 0010, 0011,
....

- Depending on the variation of amplitude, phase or frequency of the carrier, the modulation scheme is called as M-ary ASK, M-ary PSK and M-ary FSK.

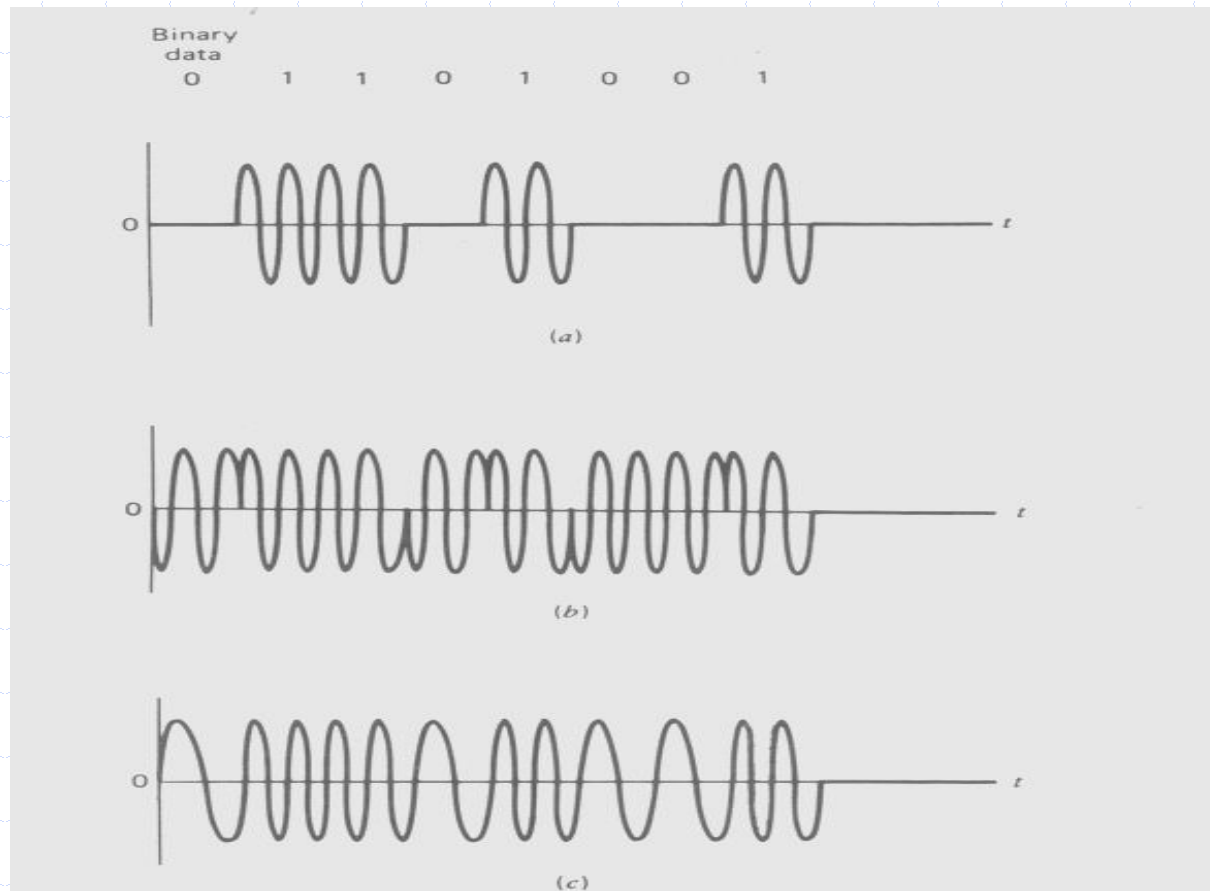

Fig: waveforms of (a) ASK (b) PSK (c)FSK

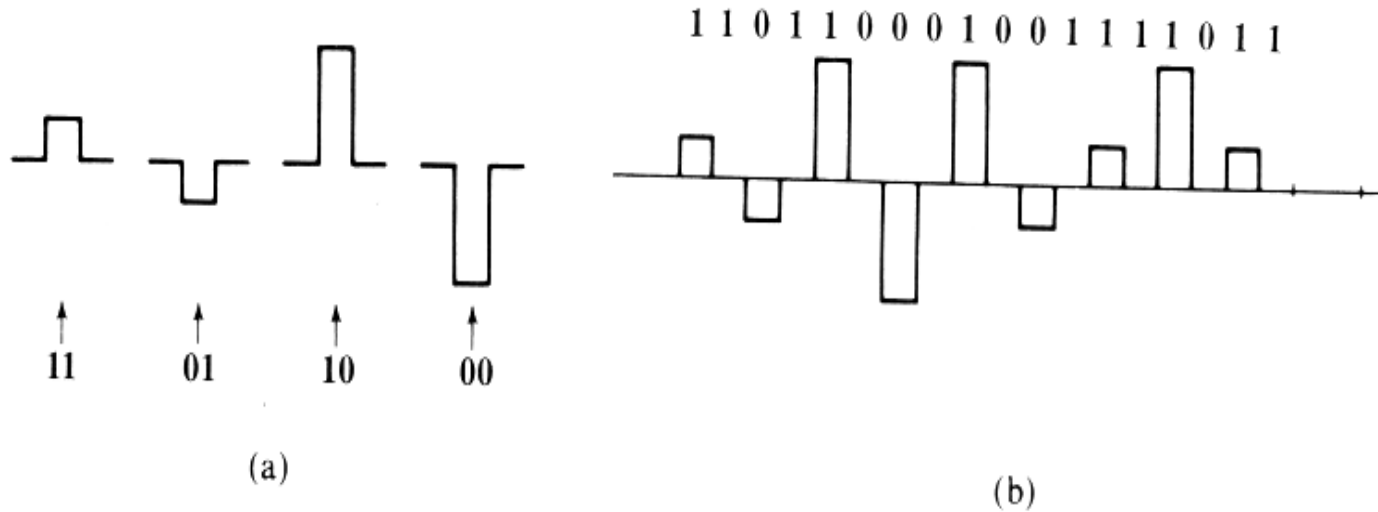

Fig: 4-ary Multiamplitude signal

M-ary Phase Shift Keying(MPSK)

- ◆ In M-ary PSK, the carrier phase takes on one of the M possible values, namely $\theta_i = 2 * (i - 1)\pi / M$ where $i = 1, 2, 3, \dots, M$.

The modulated waveform can be expressed as

$$S_i(t) = \sqrt{\frac{2E_s}{T_s}} \cos\left(2\pi f_c t + \frac{2\pi}{M}(i-1)\right), 0 \leq t \leq T_s \quad i = 1, 2, \dots, M$$

where E_s is energy per symbol = $(\log_2 M) E_b$

T_s is symbol period = $(\log_2 M) T_b$.

The above equation in the Quadrature form is

$$S_i(t) = \sqrt{\frac{2E_s}{T_s}} \cos \left[(i-1) \frac{2\pi}{M} \right] \cos(2\pi f_c t) \quad i = 1, 2, \dots, M$$
$$- \sqrt{\frac{2E_s}{T_s}} \sin \left[(i-1) \frac{2\pi}{M} \right] \sin(2\pi f_c t)$$

By choosing orthogonal basis signals

$$\phi_1(t) = \sqrt{\frac{2}{T_s}} \cos(2\pi f_c t),$$

$$\phi_2(t) = \sqrt{\frac{2}{T_s}} \sin(2\pi f_c t)$$

defined over the interval $0 \leq t \leq T_s$

◆ M-ary signal set can be expressed as

$$S_{\text{M-PSK}}(t) = \{ \sqrt{E_s} \cos \left[(i-1) \frac{\pi}{2} \right] \phi_1(t) - \sqrt{E_s} \sin \left[(i-1) \frac{\pi}{2} \right] \phi_2(t) \}$$
$$i = 1, 2, \dots, M$$

- ⑩ Since there are only two basis signals, the constellation of M-ary PSK is two dimensional.
- ⑩ The M-ary message points are equally spaced on a circle of radius $\sqrt{E_s}$, centered at the origin.
- ⑩ The constellation diagram of an 8-ary PSK signal set is shown in fig.

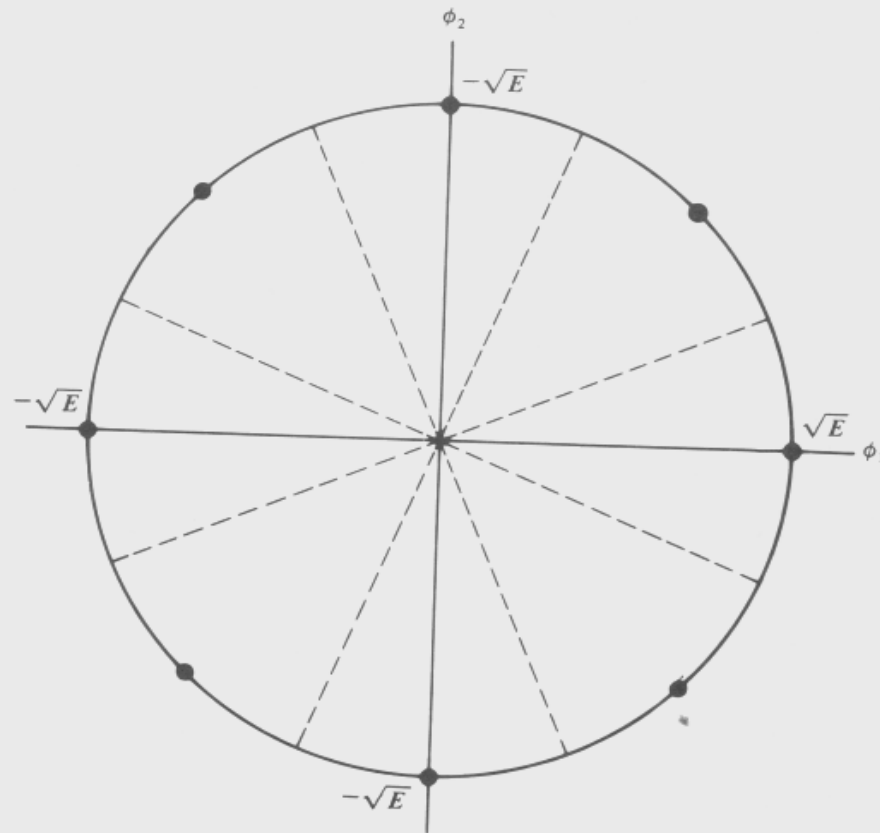

Fig: Constellation diagram of an M-ary PSK system($m=8$)

Derivation of symbol error probability:

Decision Rule:

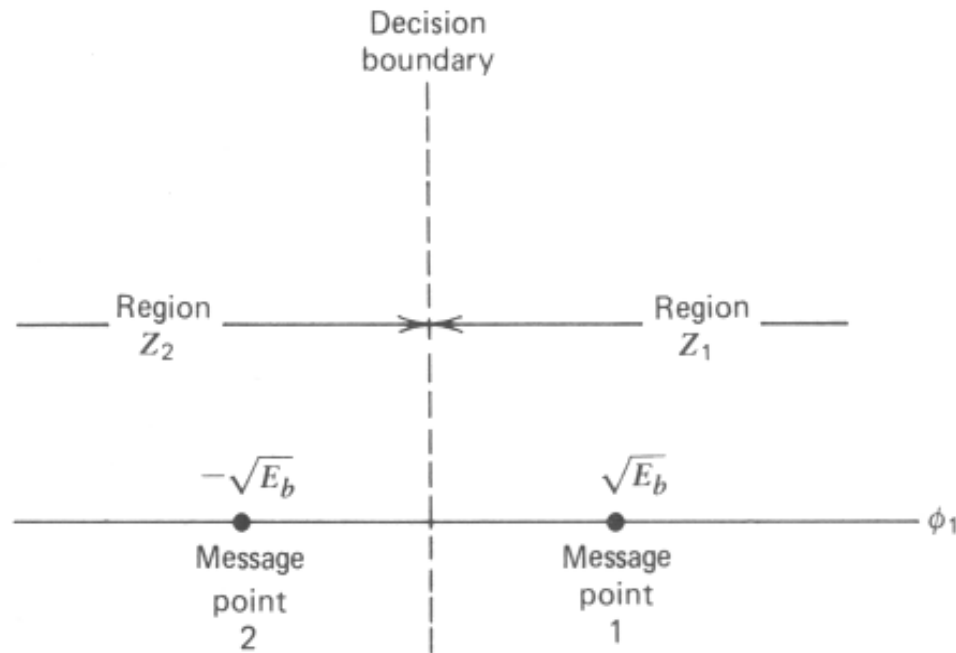

Fig: Constellation diagram for $M=2$ (Binary PSK)

- ◆ If a symbol $(0,0,0)$ is transmitted, it is clear that if an error occurs, the transmitted signal is most likely to be mistaken for $(0,0,1)$ and $(1,1,1)$ and the signal being mistaken for $(1,1,0)$ is remote.
- ◆ The decision pertaining to $(0,0,0)$ is bounded by $\theta = -\pi/8$ (below $\phi_1(t)$ - axis) to $\theta = +\pi/8$ (above $\phi_2(t)$ - axis)
- ⑩ The probability of correct reception is...

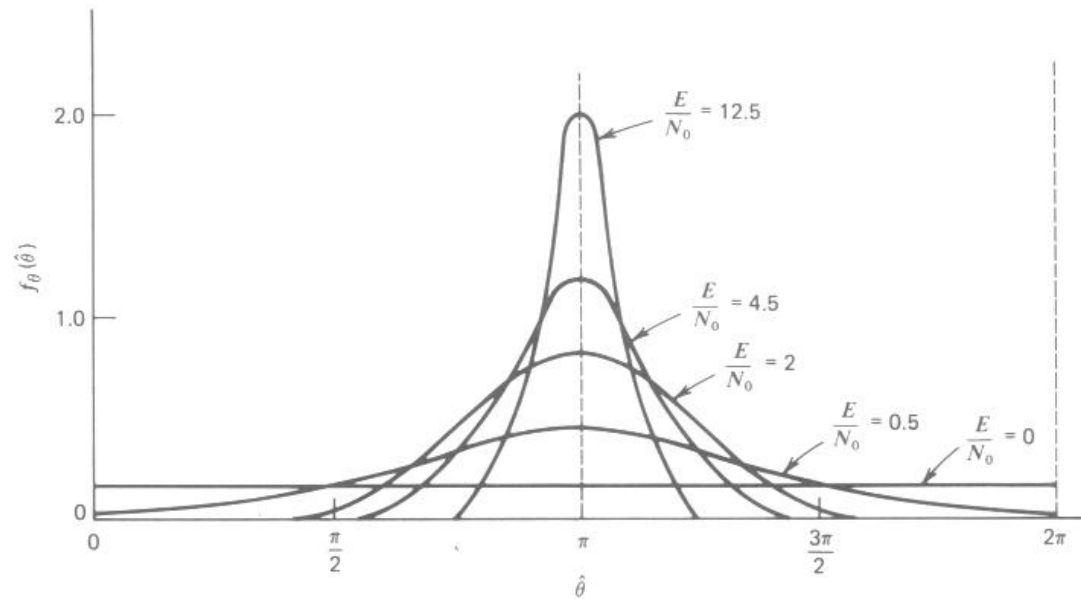

Fig: Probability density function of Phase θ .

- ◆ The average symbol error probability of an coherent M-ary PSK system in AWGN channel is given by

$$P_e \leq 2Q\left(\sqrt{\frac{2E_b \log_2 M}{N_0}} \sin\left(\frac{\pi}{M}\right)\right)$$

- ◆ Similarly, The symbol error Probability of a differential M-ary PSK system in AWGN channel is given by

$$P_e \approx 2Q\left(\sqrt{\frac{4E_s}{N_0}} \sin\left(\frac{\pi}{2M}\right)\right)$$

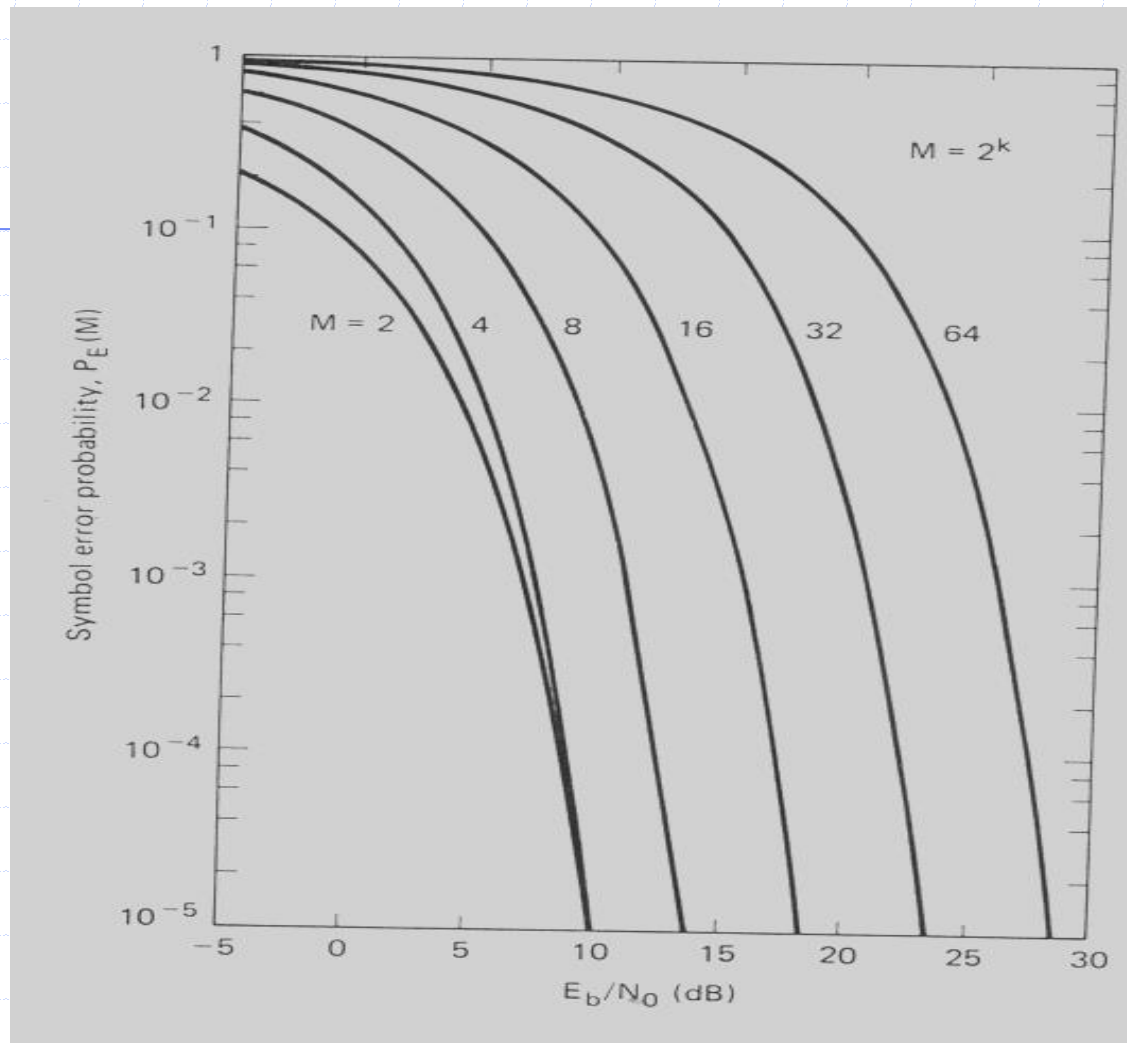

Fig: The performance of symbol error probability for -different values of M

◆ Power Efficiency and Bandwidth :

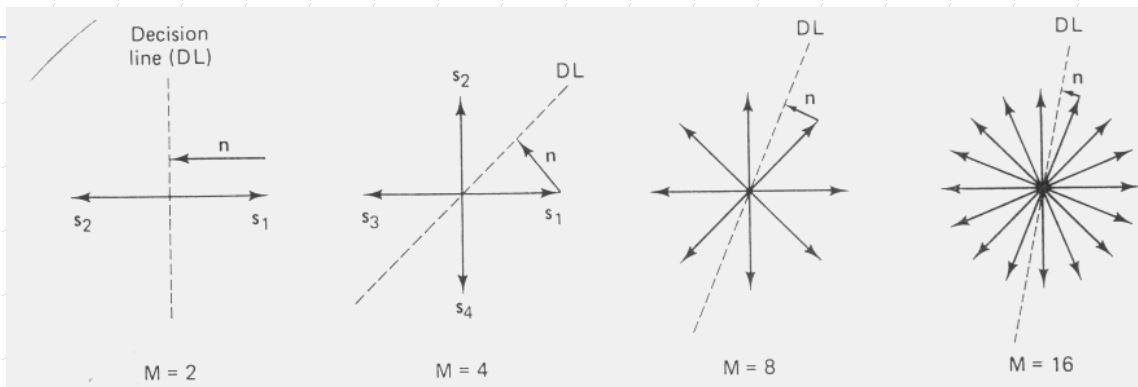

Fig: MPSK signal sets for M=2,4,8,16

Table 5.4 Bandwidth and Power Efficiency of M-ary PSK Signals

M	2	4	8	16	32	64
$\eta_B = R_b/B^*$	0.5	1	1.5	2	2.5	3
E_b/N_0 for BER= 10^{-6}	10.5	10.5	14	18.5	23.4	28.5

* B : First null bandwidth of M-ary PSK signals

Power efficiency:

- ⑩ Increasing M implies that the constellation is more densely packed, and hence the power efficiency (noise tolerance) is increased.

Bandwidth Efficiency:

- ◆ The first null bandwidth of M -ary PSK signals decrease as M increases while R_b is held constant.
- ◆ Therefore, as the value of M increases, the bandwidth efficiency also increases.

M-ary Quadrature Amplitude Modulation (QAM)

- ◆ It's a Hybrid modulation
- ◆ As we allow the amplitude to also vary with the phase, a new modulation scheme called quadrature amplitude modulation (QAM) is obtained.
- ◆ The constellation diagram of 16-ary QAM consists of a square lattice of signal points.

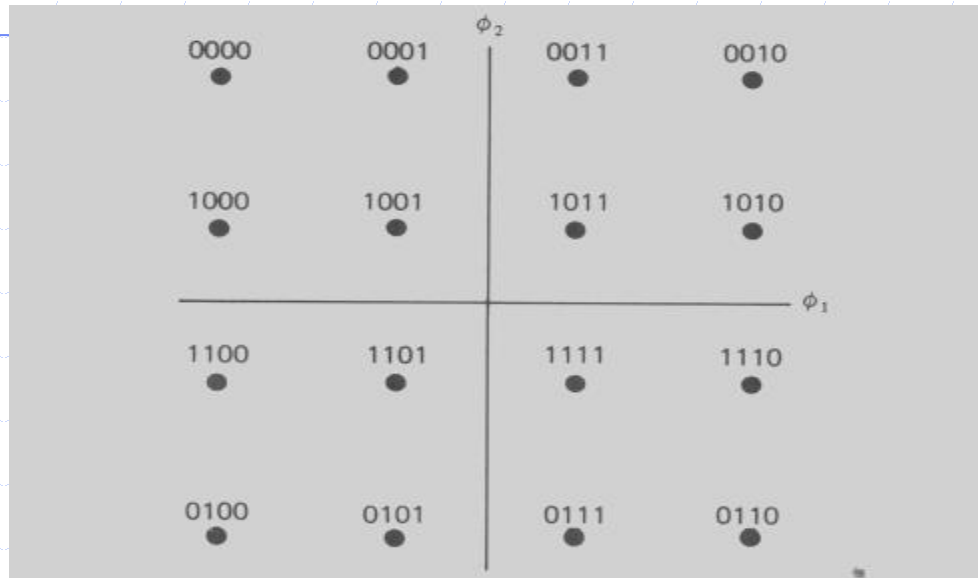

Fig: signal Constellation of M-ary QAM for M=16

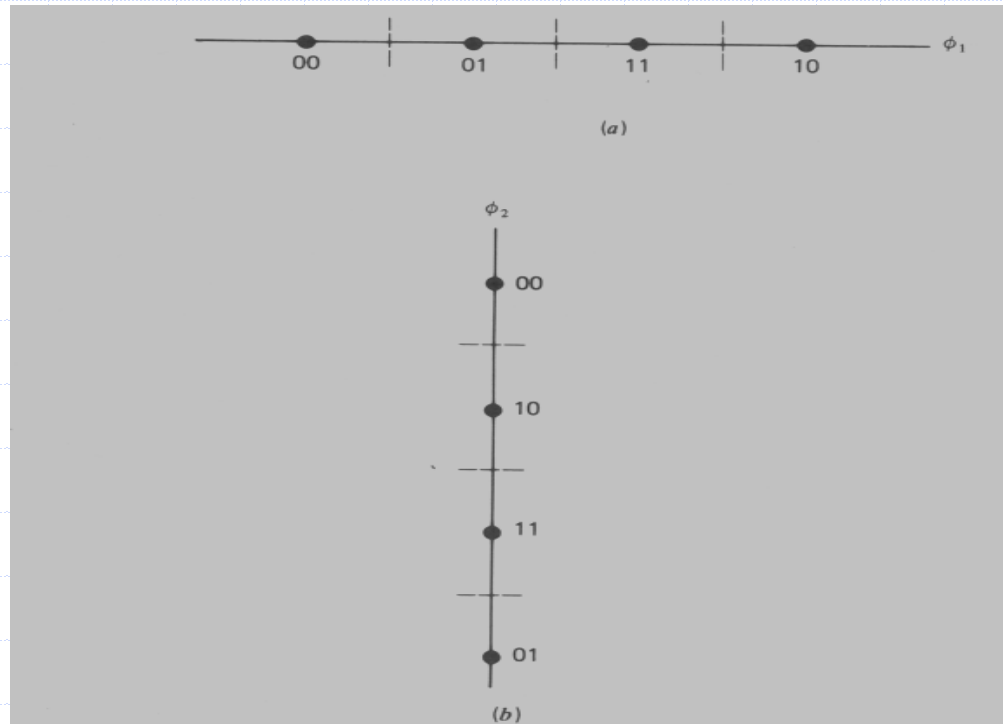

Fig: Decomposition of signal Constellation of M-ary QAM

The general form of an M-ary QAM signal can be defined as

$$S_i(t) = \sqrt{\frac{2E_{min}}{T_s}} a_i \cos(2\pi f_c t) + \sqrt{\frac{2E_{min}}{T_s}} b_i \sin(2\pi f_c t)$$
$$0 \leq t \leq T \quad i = 1, 2, \dots, M$$

where

E_{min} is the energy of the signal with the lowest amplitude
and

a_i and b_i are a pair of independent integers chosen according to the location of the particular signal point.

- ⑩ In M-ary QAM energy per symbol and also distance between possible symbol states is not a constant.

- ◆ It reasons that particular values of $S_i(t)$ will be detected with higher probability than others.

- ◆ The signal $S_i(t)$ may be expanded in terms of a pair of basis functions defined as

$$\phi_1(t) = \sqrt{\frac{2}{T_s}} \cos(2\pi f_c t) \quad 0 \leq t \leq T_s$$

$$\phi_2(t) = \sqrt{\frac{2}{T_s}} \sin(2\pi f_c t) \quad 0 \leq t \leq T_s$$

- ◆ The coordinates of the i th message point are $a_i \sqrt{E_{\text{min}}}$ and $b_i \sqrt{E_{\text{min}}}$ where (a_i, b_i) is an element of the L by L matrix given by

$$\{a_i, b_i\} = \begin{bmatrix} (-L+1, L-1) & (-L+3, L-1) & \dots & (L-1, L-1) \\ (-L+1, L-3) & (-L+3, L-3) & \dots & (L-1, L-3) \\ \vdots & \vdots & \ddots & \vdots \\ (-L+1, -L+1) & (-L+3, -L+1) & \dots & (L-1, -L+1) \end{bmatrix}$$

Where $L = \sqrt{M}$.

- ◆ For the example M=16- QAM the L by L matrix is

$$\{a_i, b_i\} = \begin{bmatrix} (-3, 3) & (-1, 3) & (1, 3) & (3, 3) \\ (-3, 1) & (-1, 1) & (1, 1) & (3, 1) \\ (-3, -1) & (-1, -1) & (1, -1) & (3, -1) \\ (-3, -3) & (-1, -3) & (1, -3) & (3, -3) \end{bmatrix}$$

Derivation of symbol error probability:

- ◆ The average probability of error in an AWGN channel is given by

$$P_e \cong 4 \left(1 - \frac{1}{\sqrt{M}} \right) Q \left(\sqrt{\frac{2E_{min}}{N_0}} \right)$$

- ◆ In terms of average signal energy, E_{avg}

$$P_e \approx 4 \left(1 - \frac{1}{\sqrt{M}} \right) Q \left(\sqrt{\frac{3E_{\text{av}}}{(M-1)N_0}} \right)$$

Power Efficiency and Bandwidth :

- ◆ Power efficiency of **QAM** is superior to M-ary PSK.
- ◆ Bandwidth efficiency of QAM is identical to M-ary PSK.

Table 5.5 Bandwidth and Power Efficiency of QAM [Zie92]

M	4	16	64	256	1024	4096
η_B	1	2	3	4	5	6
E_b/N_0 for BER= 10^{-6}	10.5	15	18.5	24	28	33.5

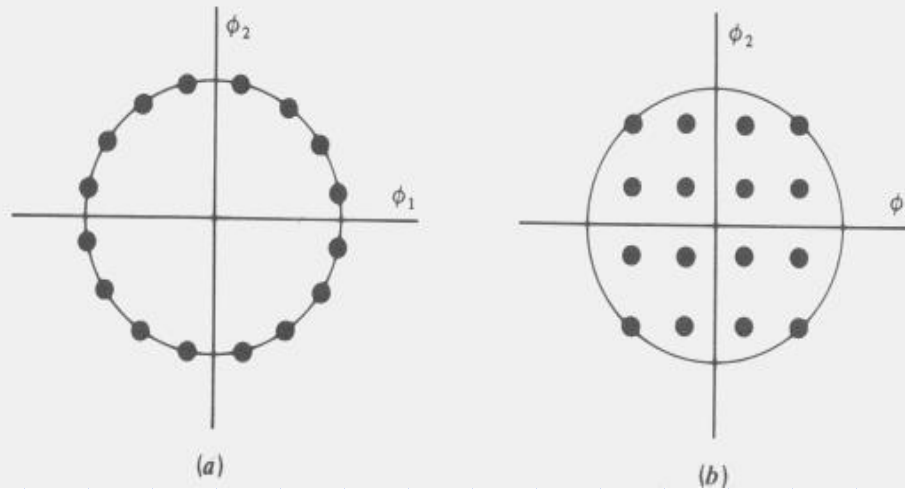

Fig: signal constellation of M-ary QPSK and M-ary QAM(M=16)

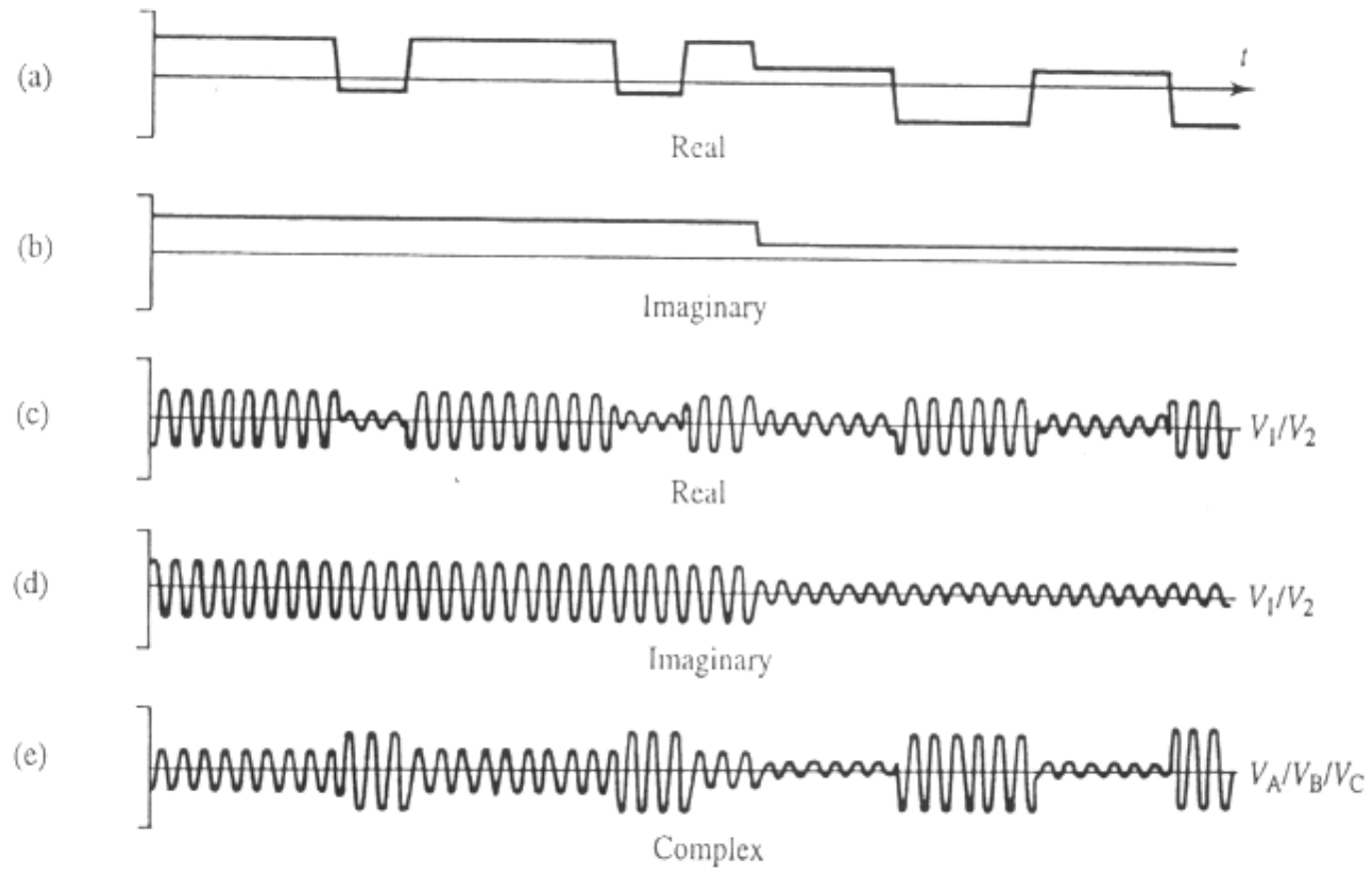

Fig: QAM for $M = 16$

M-ary Frequency Shift Keying(MFSK)

- ◆ In M-ary FSK modulation the transmitted signals are defined by:

$$S_i(t) = \sqrt{\frac{2E_s}{T_s}} \cos \left[\frac{\pi}{T_s} (n_c + i)t \right] \quad 0 \leq t \leq T_s \quad i = 1, 2, \dots, M$$

where $f_c = n_c/2T_s$, for some fixed integer n .

The M transmitted signals are of equal energy and equal duration, and the signal frequencies are separated by $1/2T_s$ Hertz, making the signals orthogonal to one another.

- ◆ The average probability of error based on the union bound is given by

$$P_e \leq (M-1) Q\left(\sqrt{\frac{\bar{E}_b \log_2 M}{N_0}}\right)$$

- ◆ Using only the leading terms of the binomial expansion:

$$P_e = \sum_{k=1}^{M-1} \left(\frac{(-1)^{k+1}}{k+1} \right) \binom{M-1}{k} \exp\left(\frac{-kE_s}{(k+1)N_0}\right)$$

Power Efficiency and Bandwidth :

Bandwidth:

Table 5.6 Bandwidth and Power Efficiency of Coherent M-ary FSK [Zie92]

M	2	4	8	16	32	64
η_B	0.4	0.57	0.55	0.42	0.29	0.18
E_b/N_o for BER= 10^{-6}	13.5	10.8	9.3	8.2	7.5	6.9

⑩ The channel bandwidth of a M-ary FSK signal is :

$$B = \frac{R_b (M + 3)}{2 \log_2 M}$$

- ◆ The channel bandwidth of a noncoherent MFSK is :

$$B = \frac{R_b M}{2 \log_2 M}$$

- ◆ This implies that the bandwidth efficiency of an M-ary FSK signal decreases with increasing M. Therefore, unlike M-PSK signals, M-FSK signals are bandwidth inefficient.