

Chemistry 4631

Instrumental Analysis

Lecture 22

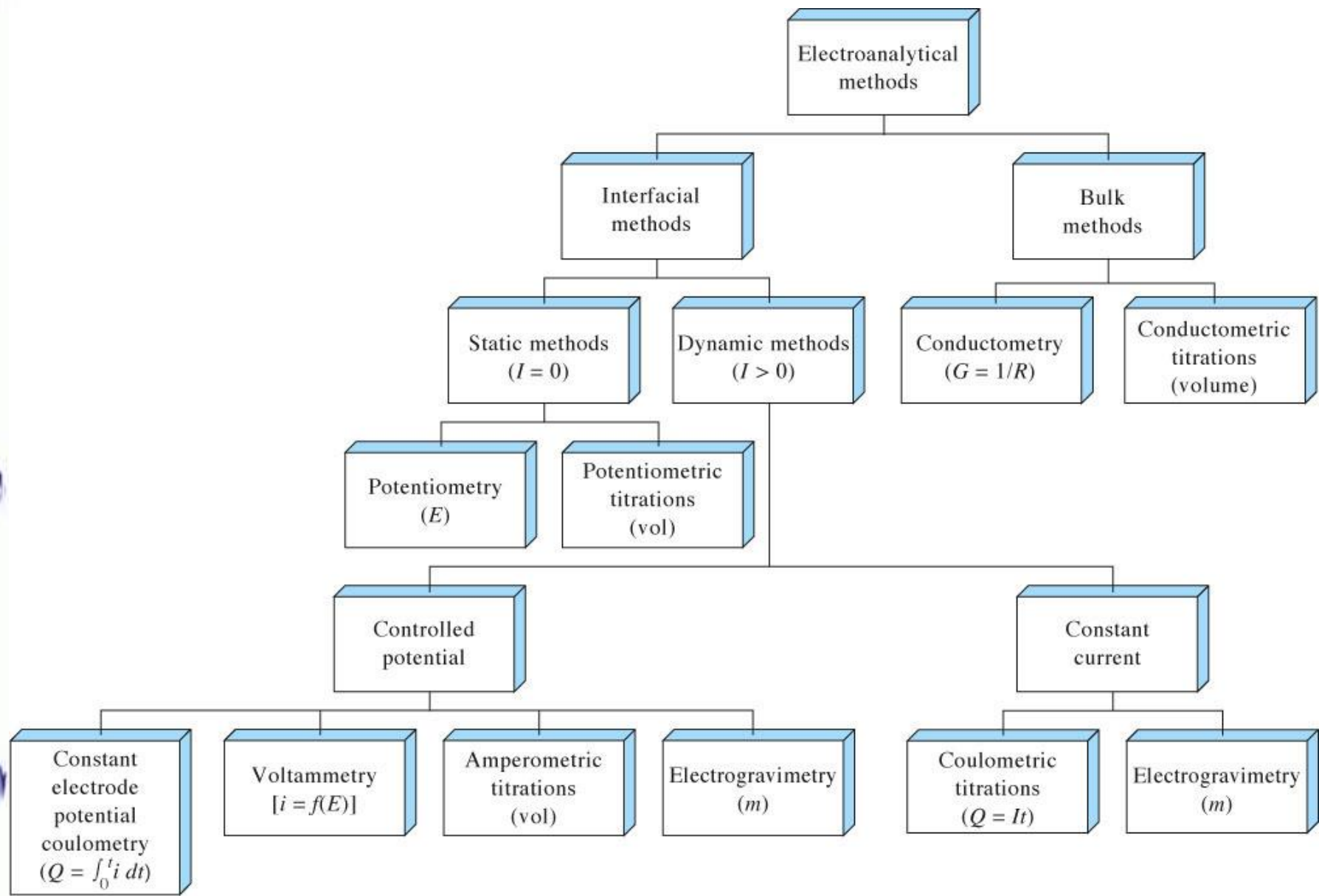

© 2007 Thomson Higher Education

Potentiometry

Measures potential under very low currents.

The cell is 2 half cells. Consist of a reference electrode, indicator electrode, and potential measuring device.

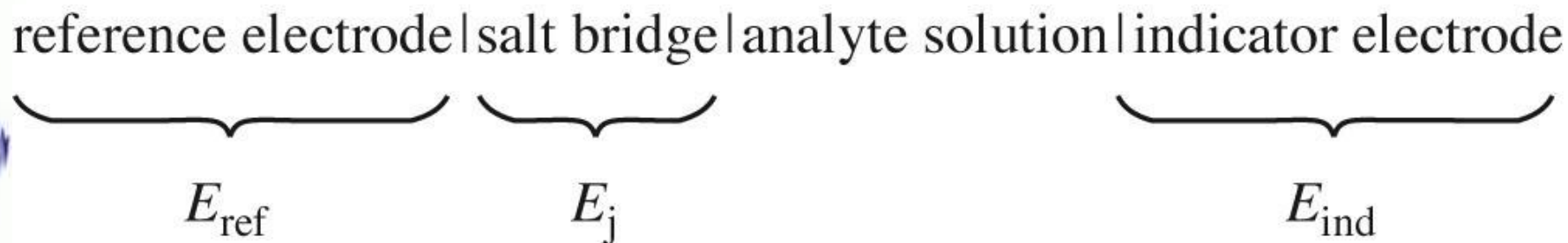

Potentiometry

Reference electrodes

An electrode with a known constant half-potential and insensitive to composition of the solution.

Ideal reference

- **Reversible and obeys Nernst Law**
- **Exhibits stable potential over time**
- **Returns to original potential in presence of small currents**
- **Not sensitive to temperature changes**

Potentiometry

TABLE 23-1 Potentials of Reference Electrodes in Aqueous Solutions

Temperature, °C	Electrode Potential vs. SHE, V				
	0.1 M ^c Calomel ^a	3.5 M ^c Calomel ^b	Saturated ^c Calomel ^a	3.5 M ^{b,c} Ag-AgCl	Saturated ^{b,c} Ag-AgCl
10	—	0.256	—	0.215	0.214
12	0.3362	—	0.2528	—	—
15	0.3362	0.254	0.2511	0.212	0.209
20	0.3359	0.252	0.2479	0.208	0.204
25	0.3356	0.250	0.2444	0.205	0.199
30	0.3351	0.248	0.2411	0.201	0.194
35	0.3344	0.246	0.2376	0.197	0.189
38	0.3338	—	0.2355	—	0.184
40	—	0.244	—	0.193	—

© 2007 Thomson Higher Education

Potentiometry

Reference Electrodes

Calomel Electrodes (SCE)

Consist of Hg in contact with solution of calomel and KCl.

Hg | Hg₂Cl₂ (saturated), KCl (xM) ||

KCl usually 0.1, 1 M, and 4.6 ← saturated SCE

SCE most commonly used reference electrode

Advantage -- easy to prepare

Disadvantage -- sensitive to temperature changes

$E^0_{SCE} = 0.244V$ at 25°C

Electrode reaction: $Hg_2Cl_2 (s) + 2e^- \rightleftharpoons 2Hg (l) + 2Cl^-(aq)$

Calomel Electrode

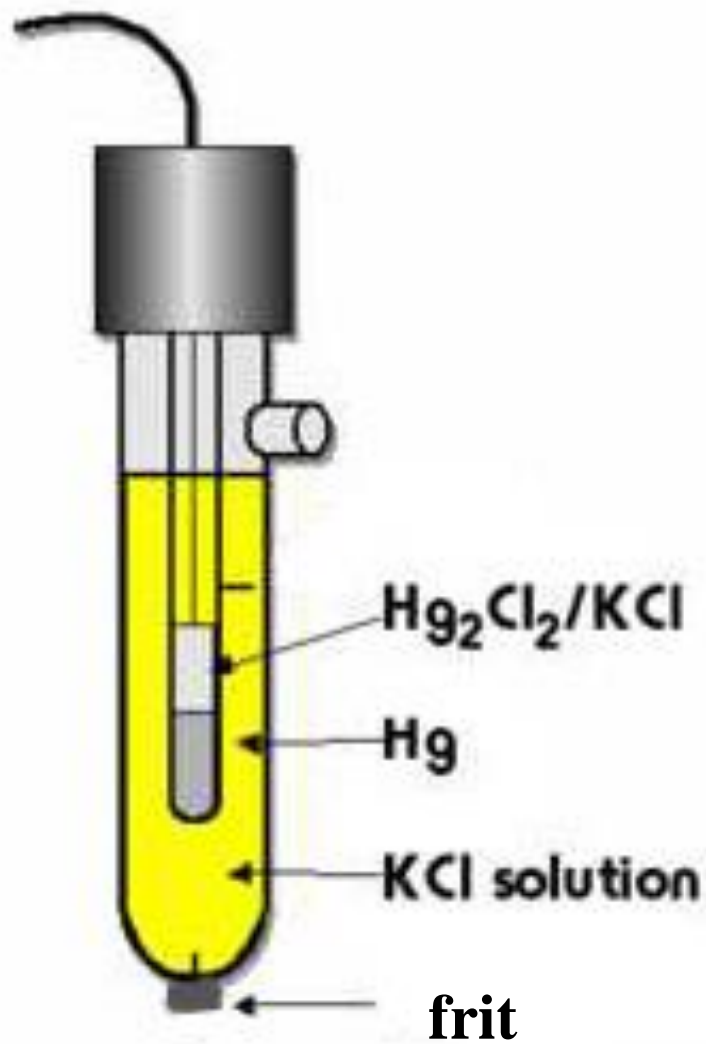

Potentiometry

Reference Electrodes

Ag/AgCl Electrodes

Ag wire in solution of KCl and AgCl

Ag | AgCl (saturated), KCl (saturated) ||



$$E^0_{\text{Ag/AgCl}} = 0.199\text{V at } 25^\circ\text{C}$$

Ag/AgCl Electrodes

saturated AgCl/KCl

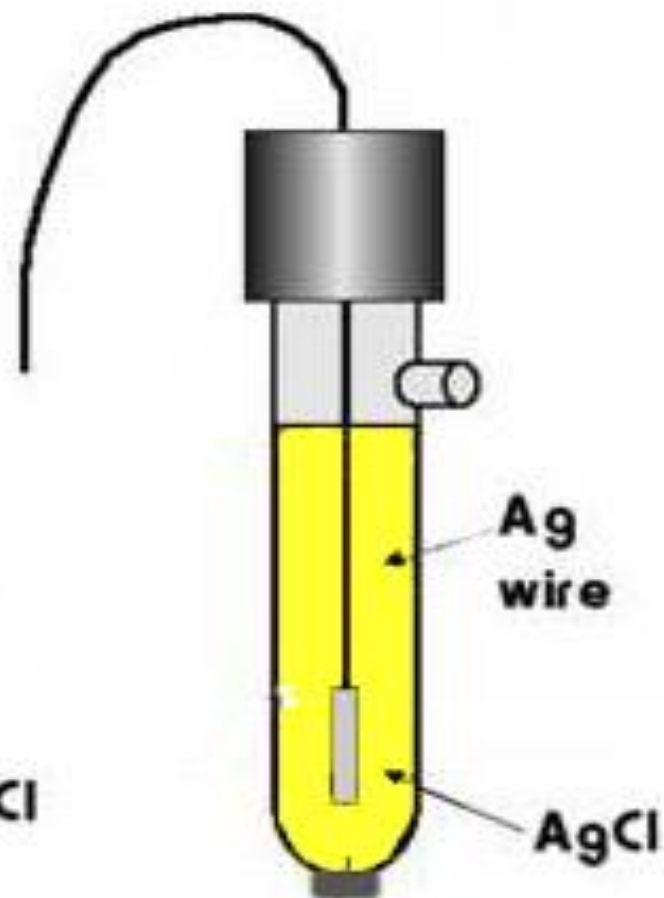

Potentiometry

Indicator Electrodes

An electrode system having a potential that varies in a known way with variations in the concentration of an analyte.

$$E_{\text{cell}} = E_{\text{ind}} - E_{\text{ref}} + E_j$$

Ideal Indicator Electrode

- **Responds quickly to concentration change of an analyte.**
- **Gives reproducible results.**

Potentiometry

Indicator Electrodes

Three type of indicator electrodes

- **Metallic**
- **Membrane**
- **Ion-selective**

Potentiometry

Indicator Electrodes

Metallic Indicator Electrodes

Electrode of the first kind

Pure metal electrode in direct equilibrium with its cation in solution.

i.e. Cu/Cu^{2+} or Ag/Ag^{+}



Potentiometry

Indicator Electrodes

Metallic Indicator Electrodes

Electrode of the first kind

Pure metal electrode in direct equilibrium with its cation in solution.

$$E_{ind} = E^{\circ}_{X^{n+}} - \frac{0.0592}{n} \log \frac{1}{a_{X^{n+}}} = E^{\circ}_{X^{n+}} + \frac{0.0592}{n} \log a_{X^{n+}}$$

$$E_{ind} = E^{\circ}_{X^{n+}} - \frac{0.0592}{n} pX$$

Potentiometry

Indicator Electrodes

Metallic Indicator Electrodes

Electrode of the first kind

Disadvantages

- not very selective, may respond to several cations
- metal may dissolve in acids
- metal may oxidized

Ag/Ag^+ , Hg/Hg^+ -- used in neutral solutions

Cu/Cu^{2+} , Zn/Zn^{2+} , Cd/Cd^{2+} , Bi/Bi^{3+} , Tl/Tl^{2+} , Pb/Pb^{2+} --
must be used in deaerated solutions

Potentiometry

Indicator Electrodes

Metallic Indicator Electrodes

Electrode of the second kind

Metal in contact with an anion that form precipitates or complexes with cations.

i.e. Ag/AgCl



Potentiometry

Indicator Electrodes

Metallic Indicator Electrodes

Electrode of the second kind

Metal in contact with an anion that form precipitates or complexes with cations.



$$E_{ind} = E^0_{AgCl} - 0.0592 \log a_{Cl^-} = E^0_{AgCl} + 0.0592 \log pCl$$

Potentiometry

Indicator Electrodes

Metallic Indicator Electrodes

Electrode of the third kind

Metal in contact with solution that responds to a different cation.

i.e. Hg electrode to measure pCa

Potentiometry

Indicator Electrodes

Metallic Indicator Electrodes

Redox system

Pt, Pd, Au or C in contact with redox system.

i.e. Pt in $\text{Ce}^{\text{III}}/\text{Ce}^{\text{IV}}$

$$E_{ind} = E^{\circ}_{\text{Ce(IV)}} - 0.0592 \log \frac{a_{\text{Ce}^{+3}}}{a_{\text{Ce}^{+4}}}$$

Potentiometry

Membrane Indicator Electrodes

Membrane Electrodes also called ion selective electrodes (ISEs) or pIon electrodes

TABLE 23-2 Types of Ion-Selective Membrane Electrodes

- | |
|--|
| <p>A. Crystalline Membrane Electrodes</p> <ol style="list-style-type: none">1. Single crystal
Example: LaF_3 for F^-2. Polycrystalline or mixed crystal
Example: Ag_2S for S^{2-} and Ag^+ <p>B. Noncrystalline Membrane Electrodes</p> <ol style="list-style-type: none">1. Glass
Examples: silicate glasses for Na^+ and H^+2. Liquid
Examples: liquid ion exchangers for Ca^{2+} and neutral carriers for K^+3. Immobilized liquid in a rigid polymer
Examples: PVC matrix for Ca^{2+} and NO_3^- |
|--|

Potentiometry

Indicator Electrodes

Membrane Electrodes

Properties

- **Minimal Solubility** – solubility in analyte solutions approaches zero
- **Electrical Conductivity** – must be small usually in the form of migration of singly charged ions within the membrane
- **Selective Reactivity** – must selectively bind with analyte ion by ion-exchange, crystallization, or complexation

Potentiometry

Indicator Electrodes

Membrane Electrodes

pION electrodes

i.e. pH Electrode -- glass electrode

No electrons transported across membrane

Membrane allows certain ion to cross while excluding others.

Potentiometry

Indicator Electrodes

Membrane Electrodes

pH Electrode -- glass electrode

Responds to changes in pH

Consist of

- a sensing electrode
- reference electrode (half-cell system)

Nowdays use a combination electrode

- a sensing electrode with a built in reference.

Potentiometry

pH Electrode

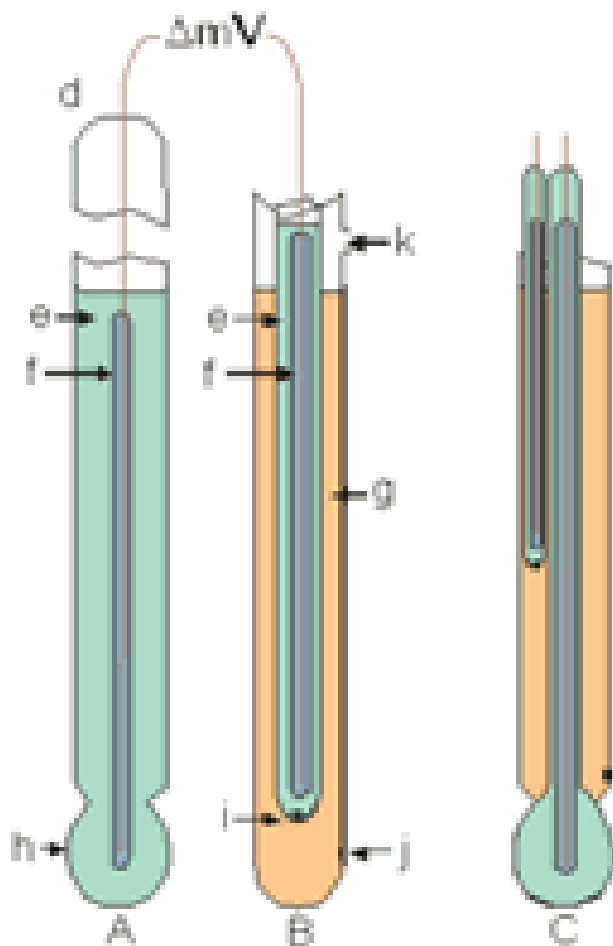

- A - pH sensor
- B - reference half cell
- C - combination pH electrode (A+B)
- D- seal
- E- internal filling solution
- F- internal reference electrode
- G- external filling solution
- H- pH sensitive glass membrane
- I- internal liquid junction
- J- external liquid junction
- K- fill hole

Potentiometry

Indicator Electrodes

Membrane Electrodes

pH Electrode -- glass electrode

The sensing electrode measures pH across the thin glass membrane

- **0.03 to 1.00 mm thick**
- **consist of 22% Na_2O , 6% CaO , 72% SiO_2**
- **or 10% Li_2O , 10% CaO , and 80% SiO_2 (for Na^+ error)**

Potentiometry

Indicator Electrodes

Membrane Electrodes

pH Electrode -- glass electrode

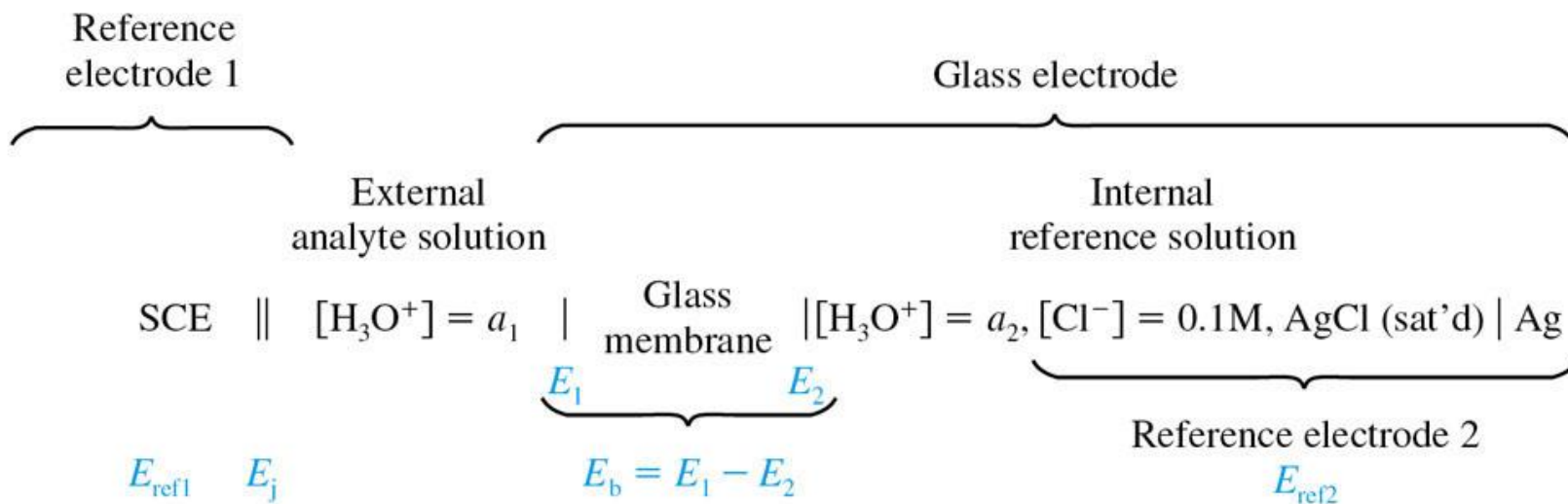

Potentiometry

Indicator Electrodes

Membrane Electrodes

pH Electrode -- glass electrode

pH measurement occurs by an ion-exchange reaction:

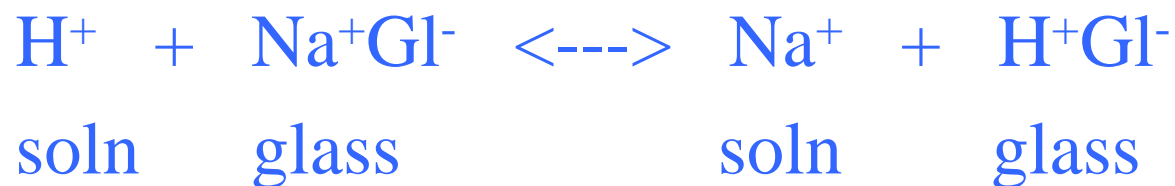

Potentiometry

pH Electrode -- glass electrode

Membrane electrodes

H_3O^+ partially populates both the inner and outer SiO_2 surfaces.

The concentration difference results in a potential across the glass membrane.

A special glass is used:
22% Na_2O , 6% CaO , 72% SiO_2

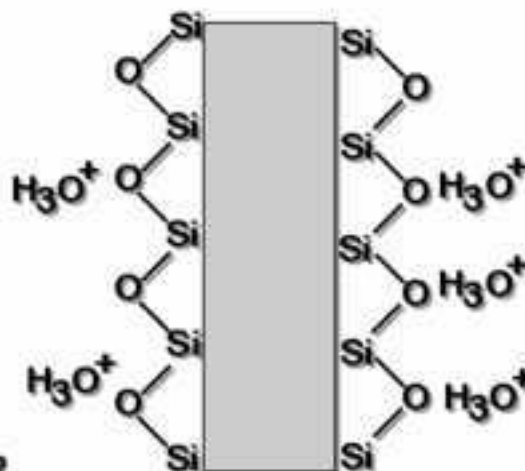

Potentiometry

Indicator Electrodes

Membrane Electrodes

Membrane electrodes can also be used to measure other ions.

1st type that were used: Na^+ , Ca^{2+} , and Cl^-

(Na^+ selective glass electrode made up of 11% Na_2O , 18% Al_2O_3 , 71% SiO_2)

Potentiometry

Indicator Electrodes

Membrane Electrodes

Instead of glass the membrane may be a polymer saturated with a liquid ion exchanger (with ion-exchange capabilities).

Ion selective electrodes - ISE's

Potentiometry

Indicator Electrodes

Membrane Electrodes

Many ISE's (and pH electrodes) are membrane-based devices which separate the sample from the inside of the electrode. On the inside is a filling solution containing the ion of interest at a constant activity.

Potentiometry

Ca ion selective electrode example

Liquid membrane electrodes

Ca²⁺ electrode

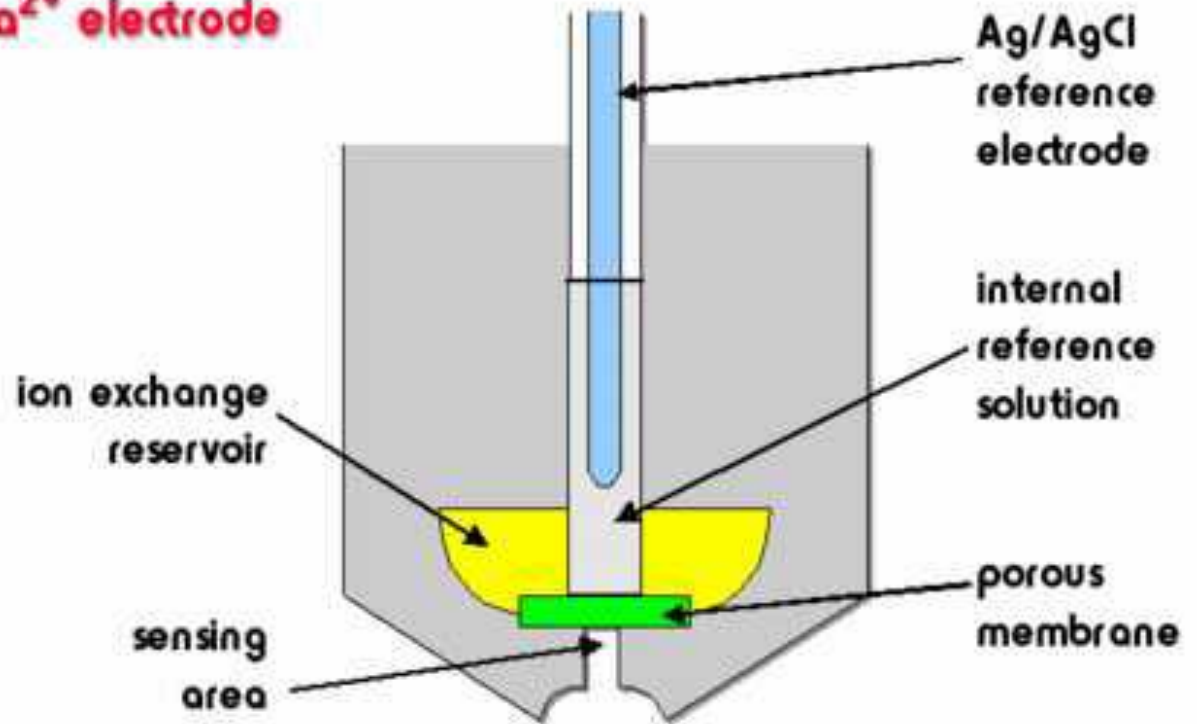

Potentiometry

Ca ion selective electrode example

Liquid membrane electrodes

The reservoir forces exchanger into the membrane.
The exchanger forms complexes with the species of interest.

The results in a concentration difference and a resulting ΔV that we can measure.

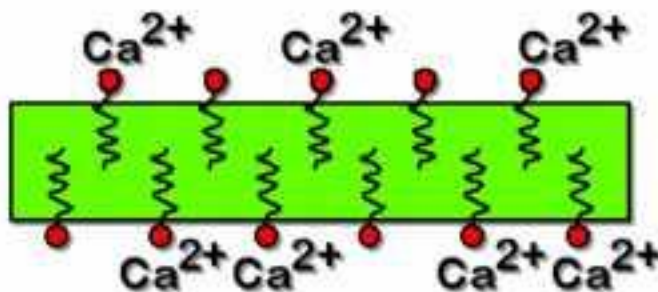

Potentiometry

Indicator Electrodes

Membrane Electrodes

A gradient is established across the membrane when the electrode is immersed in a solution.

$$\Delta G = -RT \ln(a_{\text{sample}}/a_{\text{int.soln.}}) \quad R = 8.134 \text{ J/K mol}$$

Potential produced:

$$E = -\Delta G/nF = (RT/nF) \ln(a_{\text{sample}}/a_{\text{int.soln.}})$$

Potentiometry

Indicator Electrodes

Membrane Electrodes

Potential produced:

$$E = -\Delta G/nF = (RT/nF) \ln(a_{\text{sample}}/a_{\text{int.soln.}})$$

This potential is monitored relative to a reference electrode.

E_{ref} - constant (fixed)

$a_{\text{int. soln.}}$ - constant

Potentiometry

Indicator Electrodes

Membrane Electrodes

$$E = K + (2.303RT/Z_i F) \log a_i \quad \text{where,}$$

Z_i - ionic charge

a_i - ionic activity

K - constant

Potentiometry

Indicator Electrodes

Membrane Electrodes

E is proportional to $\log a_i$

- so a **59.1 mV** change corresponds to a **10 fold change** in **a** (for monoatomic ions)
- **a_i - unity for dilute solutions**
- to relate E to [] need to use standardization curves.

Potentiometry

TABLE 23-4 Characteristics of Liquid-Membrane Electrodes

Analyte Ion	Concentration Range, M [†]	Major Interferences [‡]
NH ₄ ⁺	10 ⁰ to 5 × 10 ⁻⁷	<1 H ⁺ , 5 × 10 ⁻¹ Li ⁺ , 8 × 10 ⁻² Na ⁺ , 6 × 10 ⁻⁴ K ⁺ , 5 × 10 ⁻² Cs ⁺ , >1 Mg ²⁺ , >1 Ca ²⁺ , >1 Sr ²⁺ , >0.5 Sr ²⁺ , 1 × 10 ⁻² Zn ²⁺
Cd ²⁺	10 ⁰ to 5 × 10 ⁻⁷	Hg ²⁺ and Ag ⁺ (poisons electrode at >10 ⁻⁷ M), Fe ³⁺ (at >0.1[Cd ²⁺]), Pb ²⁺ (at >[Cd ²⁺]), Cu ²⁺ (possible)
Ca ²⁺	10 ⁰ to 5 × 10 ⁻⁷	10 ⁻⁵ Pb ²⁺ ; 4 × 10 ⁻³ Hg ²⁺ , H ⁺ , 6 × 10 ⁻³ Sr ²⁺ ; 2 × 10 ⁻² Fe ²⁺ ; 4 × 10 ⁻² Cu ²⁺ ; 5 × 10 ⁻² Ni ²⁺ ; 0.2 NH ₃ ; 0.2 Na ⁺ ; 0.3 Tris ⁺ ; 0.3 Li ⁺ ; 0.4 K ⁺ ; 0.7 Ba ²⁺ ; 1.0 Zn ²⁺ ; 1.0 Mg ²⁺
Cl ⁻	10 ⁰ to 5 × 10 ⁻⁶	Maximum allowable ratio of interferent to [Cl ⁻]: OH ⁻ 80, Br ⁻ 3 × 10 ⁻³ , I ⁻ 5 × 10 ⁻⁷ , S ²⁻ 10 ⁻⁶ , CN ⁻ 2 × 10 ⁻⁷ , NH ₃ 0.12, S ₂ O ₃ ²⁻ 0.01
BF ₄ ⁻	10 ⁰ to 7 × 10 ⁻⁶	5 × 10 ⁻⁷ ClO ₄ ⁻ ; 5 × 10 ⁻⁶ I ⁻ ; 5 × 10 ⁻⁵ ClO ₃ ⁻ ; 5 × 10 ⁻⁴ CN ⁻ ; 10 ⁻³ Br ⁻ ; 10 ⁻³ NO ₂ ⁻ ; 5 × 10 ⁻³ NO ₃ ⁻ ; 3 × 10 ⁻³ HCO ₃ ⁻ ; 5 × 10 ⁻² Cl ⁻ ; 8 × 10 ⁻² H ₂ PO ₄ ⁻ ; HPO ₄ ²⁻ ; PO ₄ ³⁻ ; 0.2 OAc ⁻ ; 0.6 F ⁻ ; 1.0 SO ₄ ²⁻
NO ₃ ⁻	10 ⁰ to 7 × 10 ⁻⁶	10 ⁻⁷ ClO ₄ ⁻ ; 5 × 10 ⁻⁶ I ⁻ ; 5 × 10 ⁻⁵ ClO ₃ ⁻ ; 10 ⁻⁴ CN ⁻ ; 7 × 10 ⁻⁴ Br ⁻ ; 10 ⁻³ HS ⁻ ; 10 ⁻² HCO ₃ ⁻ ; 2 × 10 ⁻² CO ₃ ²⁻ ; 3 × 10 ⁻² Cl ⁻ ; 5 × 10 ⁻² H ₂ PO ₄ ⁻ ; HPO ₄ ²⁻ ; PO ₄ ³⁻ ; 0.2 OAc ⁻ ; 0.6 F ⁻ ; 1.0 SO ₄ ²⁻
NO ₂ ⁻	1.4 × 10 ⁻⁶ to 3.6 × 10 ⁻⁶	7 × 10 ⁻¹ salicylate, 2 × 10 ⁻³ I ⁻ , 10 ⁻¹ Br ⁻ , 3 × 10 ⁻¹ ClO ₃ ⁻ , 2 × 10 ⁻¹ acetate, 2 × 10 ⁻¹ HCO ₃ ⁻ , 2 × 10 ⁻¹ NO ₃ ⁻ , 2 × 10 ⁻¹ SO ₄ ²⁻ , 1 × 10 ⁻¹ Cl ⁻ , 1 × 10 ⁻¹ ClO ₄ ⁻ , 1 × 10 ⁻¹ F ⁻
ClO ₄ ⁻	10 ⁰ to 7 × 10 ⁻⁶	2 × 10 ⁻³ I ⁻ ; 2 × 10 ⁻² ClO ₃ ⁻ ; 4 × 10 ⁻² CN ⁻ , Br ⁻ ; 5 × 10 ⁻² NO ₂ ⁻ , NO ₃ ⁻ ; 2 HCO ₃ ⁻ , CO ₃ ²⁻ ; Cl ⁻ , H ₂ PO ₄ ⁻ , HPO ₄ ²⁻ , PO ₄ ³⁻ , OAc ⁻ , F ⁻ , SO ₄ ²⁻
K ⁺	10 ⁰ to 1 × 10 ⁻⁶	3 × 10 ⁻⁴ Cs ⁺ ; 6 × 10 ⁻³ NH ₄ ⁺ , Tl ⁺ ; 10 ⁻² H ⁺ ; 1.0 Ag ⁺ , Tris ⁺ ; 2.0 Li ⁺ , Na ⁺
Water hardness (Ca ²⁺ + Mg ²⁺)	10 ⁻³ to 6 × 10 ⁻⁶	3 × 10 ⁻⁵ Cu ²⁺ , Zn ²⁺ ; 10 ⁻⁴ Ni ²⁺ ; 4 × 10 ⁻⁴ Sr ²⁺ ; 6 × 10 ⁻⁵ Fe ²⁺ ; 6 × 10 ⁻⁴ Ba ²⁺ ; 3 × 10 ⁻² Na ⁺ ; 0.1 K ⁺

All electrodes are the plastic-membrane type.

Potentiometry

Indicator Electrodes

Solid State Electrodes

Eventually membrane electrodes (ISE's) lead to solid-state electrodes

TABLE 23-3 Characteristics of Solid-State Crystalline Electrodes

Analyte Ion	Concentration Range, M	Major Interferences
Br ⁻	10 ⁰ to 5 × 10 ⁻⁶	CN ⁻ , I ⁻ , S ²⁻
Cd ²⁺	10 ⁻¹ to 1 × 10 ⁻⁷	Fe ²⁺ , Pb ²⁺ , Hg ²⁺ , Ag ⁺ , Cu ²⁺
Cl ⁻	10 ⁰ to 5 × 10 ⁻⁵	CN ⁻ , I ⁻ , Br ⁻ , S ²⁻ , OH ⁻ , NH ₃
Cu ²⁺	10 ⁻¹ to 1 × 10 ⁻⁸	Hg ²⁺ , Ag ⁺ , Cd ²⁺
CN ⁻	10 ⁻² to 1 × 10 ⁻⁶	S ²⁻ , I ⁻
F ⁻	Sat'd to 1 × 10 ⁻⁶	OH ⁻
I ⁻	10 ⁰ to 5 × 10 ⁻⁸	CN ⁻
Pb ²⁺	10 ⁻¹ to 1 × 10 ⁻⁶	Hg ²⁺ , Ag ⁺ , Cu ²⁺
Ag ⁺ /S ²⁻	Ag ⁺ : 10 ⁰ to 1 × 10 ⁻⁷ S ²⁻ : 10 ⁰ to 1 × 10 ⁻⁷	Hg ²⁺
SCN ⁻	10 ⁰ to 5 × 10 ⁻⁶	I ⁻ , Br ⁻ , CN ⁻ , S ²⁻

Potentiometry

Indicator Electrodes

Solid State Electrodes

Crystal electrodes

Example - fluoride ion-selective electrode

Consist of :

- LaF_3 crystal
- Internal electrolyte solution (0.1 M NaF and 0.1 M KCl)
- Ag/AgCl wire



Potentiometry

Indicator Electrodes

Solid State Electrodes

Crystal electrodes

Example - fluoride ion-selective electrode

LaF_3 crystal is doped with EuF_2 to provide vacancies (holes) of a fluoride ion site.

Nerstian response is obtained down to 10^{-6}M

$$E = K - 0.0591 \log a_{\text{F}^-}$$

Interference (OH^-) - has a similar size and charge, so the pH range for the electrode is only 0 to 8.5

Potentiometry

Indicator Electrodes

Solid State Electrodes

ISFET - ion selective field effect transistor

- Coat a transistor with a chemically sensitive material
- Analyte in contact with material and reference electrode
- Change in analyte concentration give a change in electrochemical potential

Advantages - rugged, small, inert, rapid response

Disadvantage – must have a reference electrode

Potentiometry

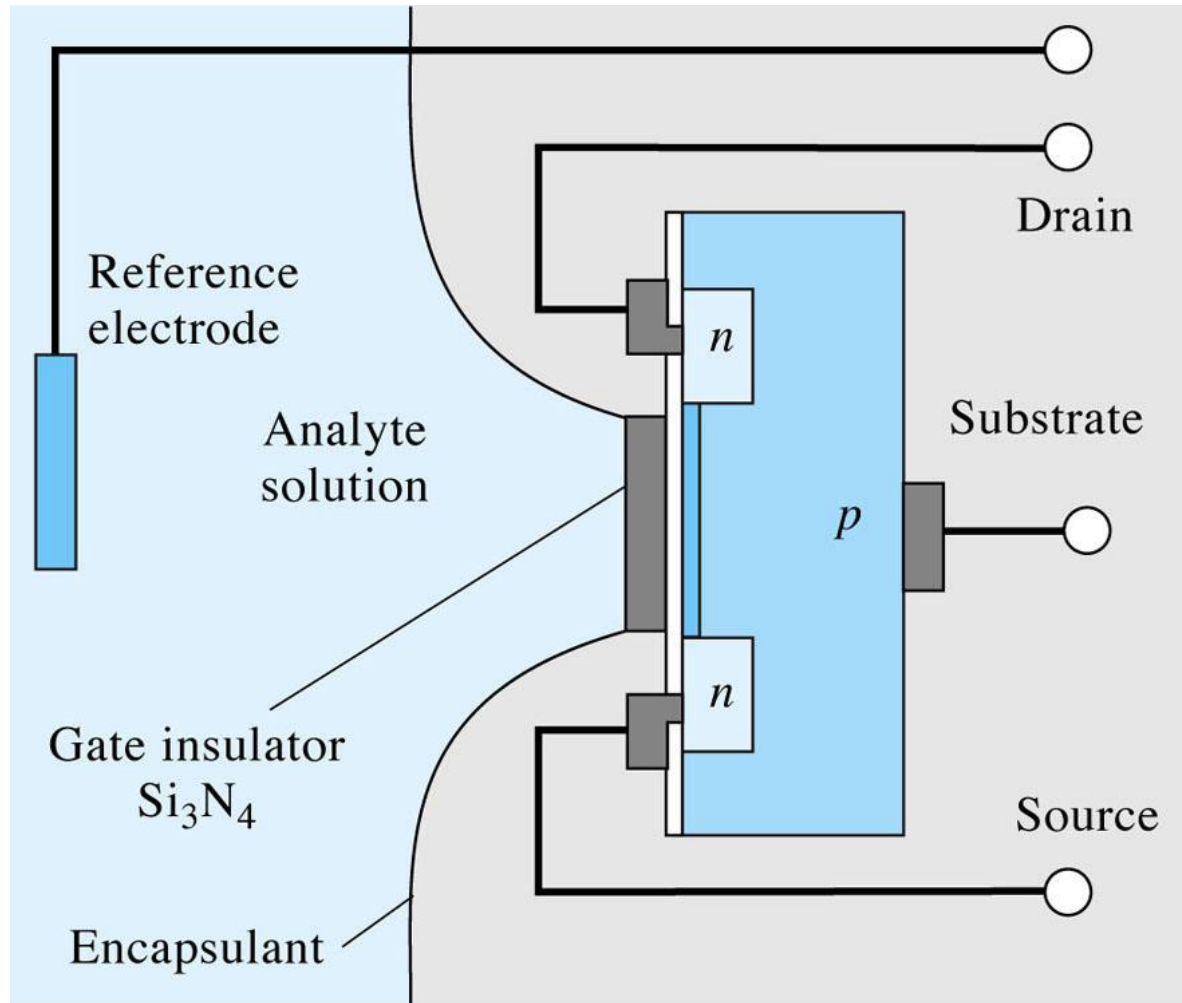

© 2007 Thomson Higher Education

Assignment

- Read Chapter 22
- HW12 Chapter 22: 1, 5, 7, 9, and 11
- HW12 Due 3/10/21

- Read Chapter 23
- HW13 Chapter 23: 2, 4, 7, 8, and 11
- HW13 Chapter 23 Due 3/17/21

