

FLUORIMETRY

CONTENTS

Principle

Factors effecting fluorescence intensity

Instrumentation

Applications

Conclusion

References.



FLUORESCENCE

- It is a phenomenon of emission of radiation when the molecules are excited by radiation at certain wavelength.



❖ **FLUORIMETRY:-** It is measurement of fluorescence intensity at a particular wavelength with the help of a filter fluorimeter or a spectrofluorimeter.

- ❑ **PRINCIPLE:-** Molecule contains σ electrons, π electrons and non bonding (n) electron.
- The electrons may be present in bonding molecular orbital. It is called as highest occupied molecular orbital (HOMO). It has least energy and more stable.
- When the molecules absorb radiant energy from a light source, the bonding electrons may be promoted to anti bonding molecular orbital (LUMO). It has more energy and hence less stable.

- The process of promotion of electrons from HOMO to LUMO with absorption of energy is called as excitation.
- **Singlet state**:- a state in which all the electrons in a molecule are paired $\downarrow\uparrow$
- **Doublet state**:- a state in which unpaired electrons is present \downarrow or \uparrow
- **Triplet state**:- a state in which unpaired electrons of same spin present $\uparrow\uparrow$
- **Singlet excited state**:- a state in which electrons are unpaired but of opposite spin like $\uparrow\downarrow$ (un paired and opposite spin)



- When light of appropriate wavelength is absorbed by a molecule the electrons are promoted from singlet ground state to singlet excited state. once the molecule is in this excited state relaxation can occur via several process. For ex by emission of radiation . The process can be the following

- 1) Collisional deactivation
- 2) Fluorescence
- 3) Phosphorescence.



Jablonski Energy Diagram

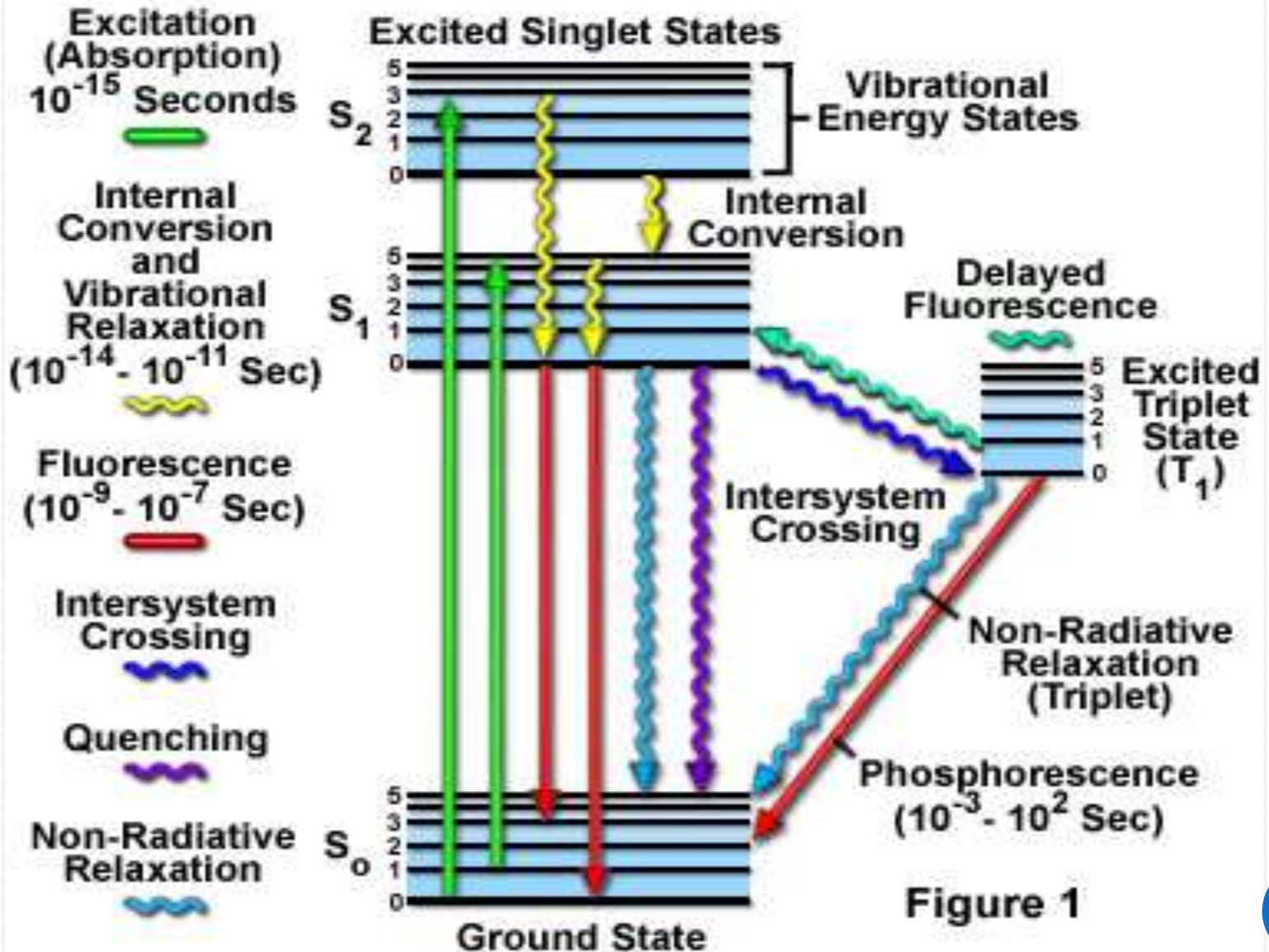

Figure 1

FIGURE 1

- **Collisional de activation** :- In which entire energy lost due to collision de activation and no radiation emitted.
- **Fluorescence**:-excited singlet state is highly unstable. Relaxation of electrons from excited singlet to singlet ground state with emission of light.
- **Phosphorescence**:-At favorable condition like low temperature and absence of oxygen there is transition from excited singlet state to triplet state which is called as inner system crossing. The emission of radiation when electrons undergo transition from **triplet state to singlet ground state** is called as phosphorescence.



➤ **Factors effecting fluorescence intensity:-**

1. Concentration
2. Quantum yield of fluorescence
3. Intensity of incident light
4. Adsorption
5. Oxygen
6. Ph
7. Temperature & viscosity
8. Photodecomposition
9. Quenchers
10. Scatter



Concentration:-

Fluorescence intensity is proportional to concentration of substance only when the absorbance is less than 0.02

$$A = \log I_0 \setminus I_t \text{ or } A = abc$$

I_0 = intensity of incident light

a = absorptivity of constant

b = Pathlength

c = concentration



➤ **QUANTUM YIELD OF FLUORESCENCE:-**
 (ϕ)

**(ϕ) =NUMBER OF PHOTONS EMITTED **
NUMBER OF PHOTONS ABSORBEDS

It Is Always Less Than 1.0. Since Some Energy Is Lost By **Radiation** less Pathways (Collisional, Intersystem Crossing, Vibrational Relaxation)



➤ **INTENSITY OF INCIDENT LIGHT:-**

Increase In The Intensity Of Incident Light On The Sample Fluorescence Intensity Also Increases.

➤ **ADSORPTION:-**

Adsorption Of Sample Solution In The Container May Leads To A Serious Problem.

➤ **OXYGEN:-**

Oxidation of fluorescent species to a non fluorescent species, quenches fluorescent substance.

➤ **Ph:-**

Alteration of ph of a solution will have significant effect on fluorescence

For ex Aniline in alkali medium gives **visible** fluorescence but in **acidic condition** gives fluorescence in visible region.



➤ **Temperature and viscosity:-**

- Temperature Increases Can Increase the collisional de activation, and reduce fluorescent intensity.
- If viscosity of solution is **more** the frequency of collisions are **reduced** and increase in fluorescent intensity.

➤ **Photochemical decomposition :-**

- Absorption of intense radiation leads to **photochemical decomposition** of a fluorescent substance to less fluorescent or non fluorescent substance.



➤ **Quenchers:-**

○ Quenching is the **reduction of fluorescence intensity** by the presence of substance in the sample other than the fluorescent analyte.

○ Quenching is following types:-

❖ **INNER FLUORESCENT EFFECT**

❖ **CONCENTRATION QUENCHING/SELF QUENCHING**

❖ **COLLISIONAL QUENCHING**

❖ **STATIC QUENCHING**



- ***INNER FLUORESCENT EFFECT:-*** Absorption Of Incident (uv) Light Or Emitted (fluorescent) Light By **Primary And Secondary Filters** Leads To Decrease In Fluorescence intensity.
- ***SELF QUENCHING:-***At Low Concentration **Linearity Is Observed**, At High Concentration Of The Same Substance Increase In Fluorescent Intensity Is Observed. This phenomena is called self quenching.



- ***COLLISIONAL QUENCHING:-*** Collisions between the fluorescent substance and halide ions leads to reduction in fluorescence intensity.
- ***STATIC QUENCHING:-*** This occurs because of complex formation between the fluorescent molecule and other molecules.
- Ex: caffeine reduces fluorescence of riboflavin.



- **SCATTER:-** Scatter is mainly due to colloidal particles in solution. Scattering of incident light after passing through the sample leads to **decrease** in fluorescence intensity.



INSTRUMENTATION



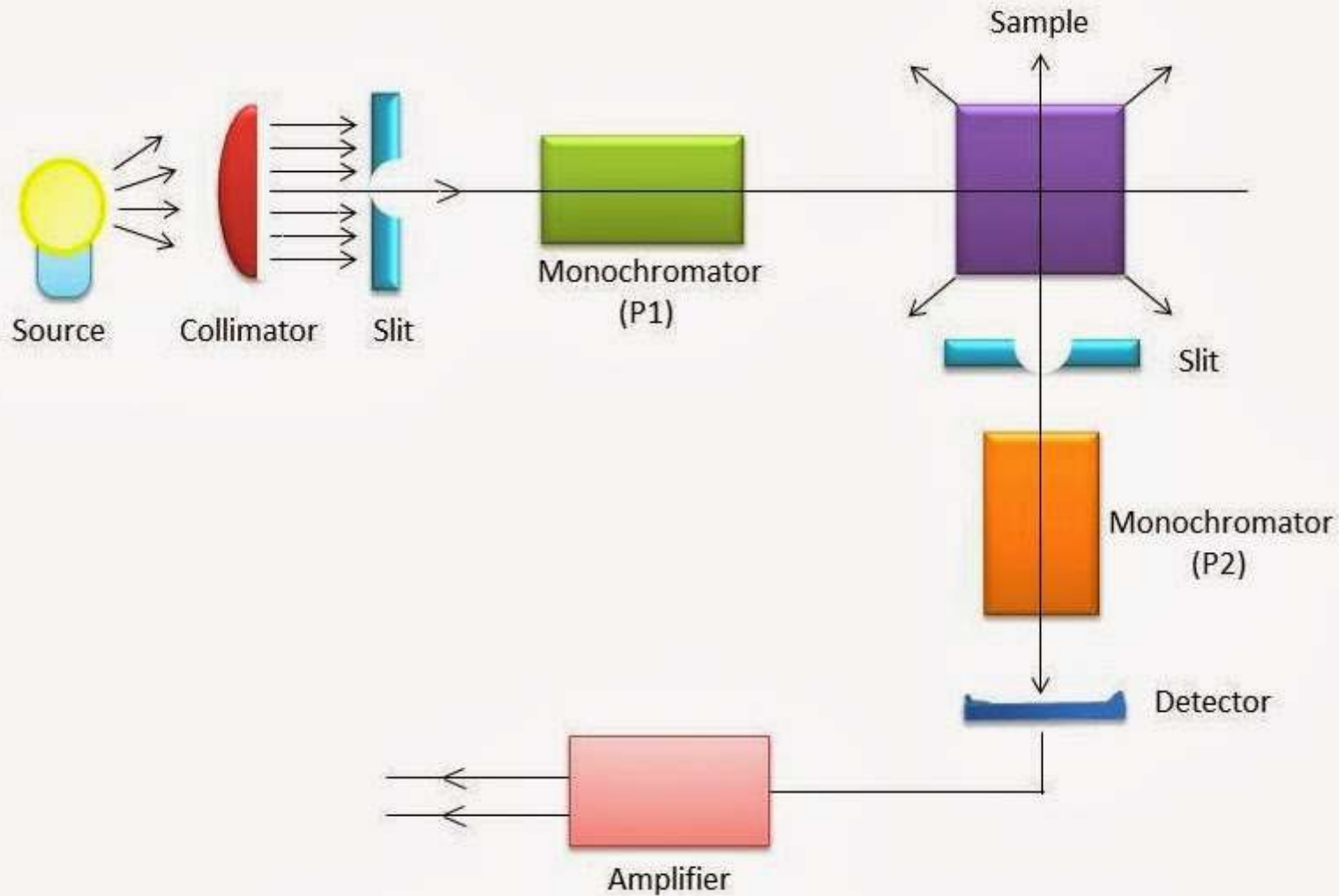

Representative Diagram of a Spectrofluorimeter for 90° Illumination

Namrata Heda

FIGURE 2

INSTRUMENTATION

SOURCE OF LIGHT

FILTERS AND MONOCHROMATORS

SAMPLE CELLS

DETECTORS



❖ 1)SOURCE OF LIGHT:-

- *mercury vapour lamp*: Mercury vapour at high pressure give intense lines on continuous background above 350nm.low pressure mercury vapour gives an additional line at 254nm.it is used in **filter fluorimeter**.



FIGURE 3



- ***xenon arc lamp***: It give more intense radiation than mercury vapour lamp. it is used in spectrofluorimeter.

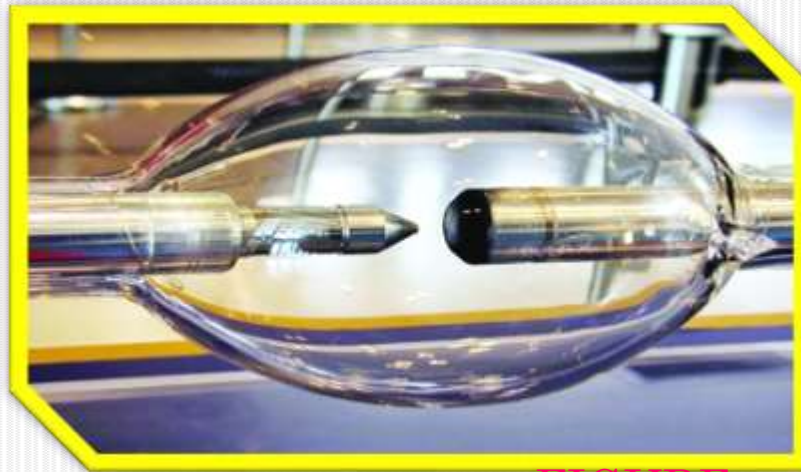

FIGURE 4

- ***tungsten lamp***:- If excitation has to be done in **visible region** this can be used. It is used in low cost instruments.



FIGURE 5



❖ 2) FILTERS AND MONOCHROMATORS:-

- **Filters:** these are nothing but optical filters works on the principle of **absorption of unwanted light** and transmitting the required wavelength of light. In inexpensive instruments fluorimeter primary filter and secondary filter are present.

Primary filter:-absorbs **visible** radiation

- and transmit UV radiation.

Secondary filter:-absorbs **UV radiation** and transmit visible radiation.



FIGURE 6

- **Monochromators:** they convert **polychromatic light into monochromatic light**. They can isolate a specific range of wavelength or a particular wavelength of radiation from a source.
- Excitation monochromators:- provides suitable radiation for excitation of molecule .
- Emission monochromators:- isolate only the radiation emitted by the fluorescent molecules.

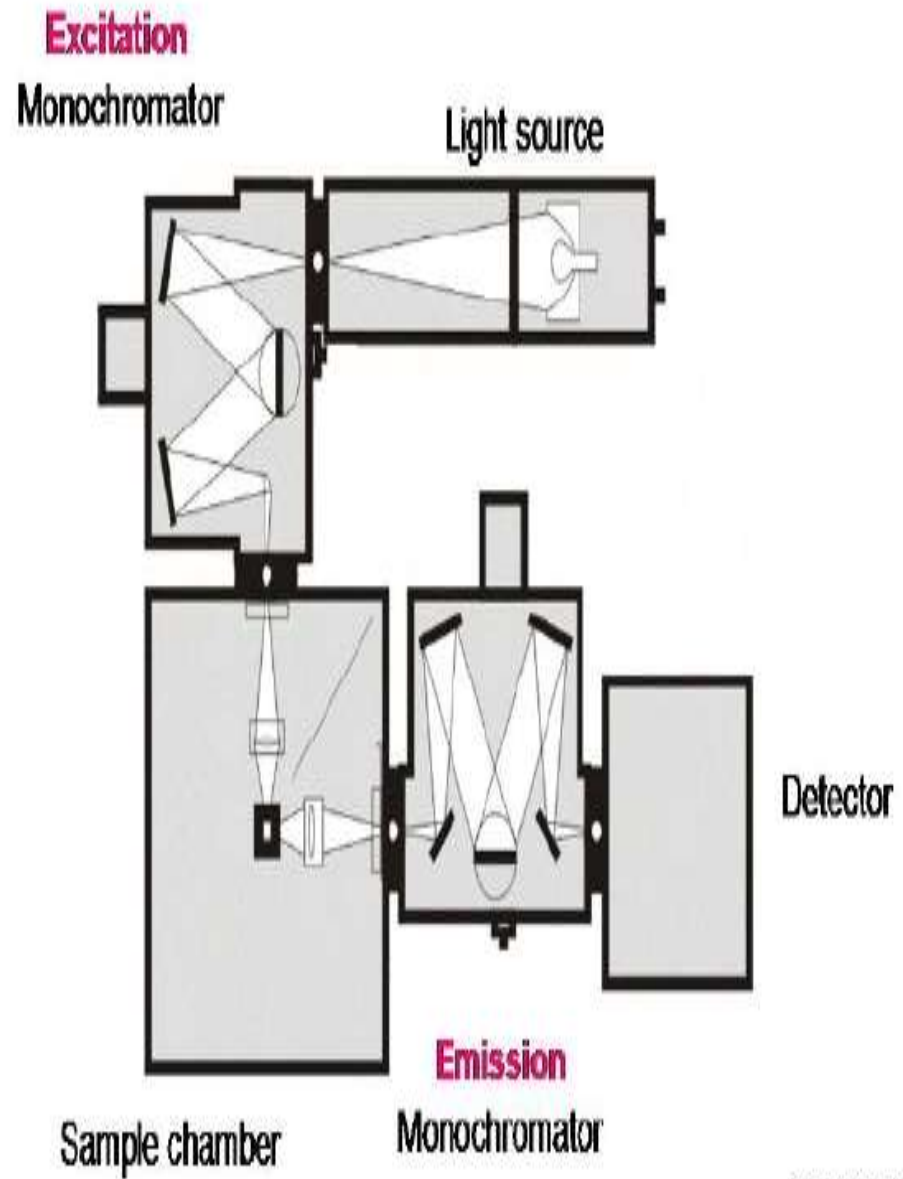

FIGURE 7

- ❖ **3) Sample cells:** These are meant for holding liquid samples. These are made up of quartz and can have various shapes ex: **cylindrical** or **rectangular** etc.



FIGURE 8

- ❖ **4) Detectors:** Photometric detectors are used they are
 - ✓ Barrier layer cell/Photo voltaic cells
 - ✓ Photomultiplier cells



○ 1. Barrier layer /photovoltaic cell:

- it is employed in inexpensive instruments. For ex: Filter Fluorimeter.
- It consists of a copper plate coated with a thin layer of cuprous oxide (Cu_2O). A semi transparent film of silver is laid on this plate to provide good contact.
- When external light falls on the oxide layer, the electrons emitted from the oxide layer move into the copper plate.
- Then oxide layer becomes positive (+) and copper plate becomes negative (-)



- Hence an Emf develops between the **oxide layer** and **copper plate** and behaves like a voltaic cell. So it is called photovoltaic cell..
- A **galvanometer** is connected externally between **silver film and copper plate** and the deflection in the galvanometer shows the **current flow** through it.
- **The amount of current is found to be proportional to the intensity of incident light**



BARRIER LAYER CELL

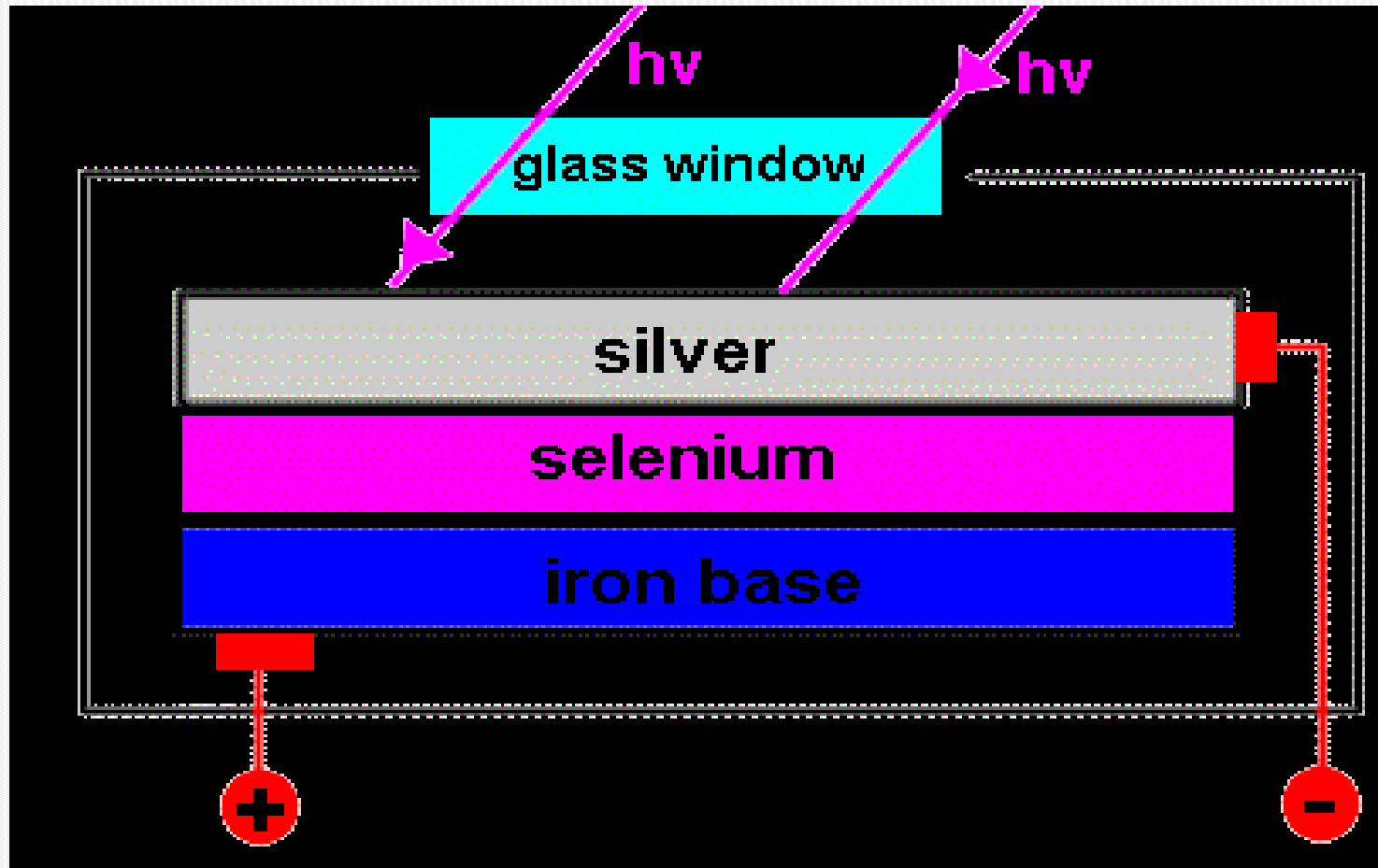

FIGURE 9

○ 2. Photomultiplier tubes:

- These are incorporated in expensive instruments like spectrofluorimeter. Its sensitivity is high due to measuring weak intensity of light.
- The principle employed in this detector is that, “multiplication of photoelectrons by secondary emission of electrons.”
- This is achieved by using a photo cathode and a series of anodes (Dyanodes). Up to 10 dyanodes are used. Each dyanode is maintained at 75-100V higher than the preceding one.



- At each stage, the electron emission is multiplied by a factor of 4 to 5 due to secondary emission of electrons and hence an overall factor of 10^6 is achieved.
- PMT can detect very weak signals, even 200 times weaker than that could be done using photovoltaic cell. Hence it is useful in fluorescence measurements.
- PMT should be shielded from stray light in order to have accurate results.



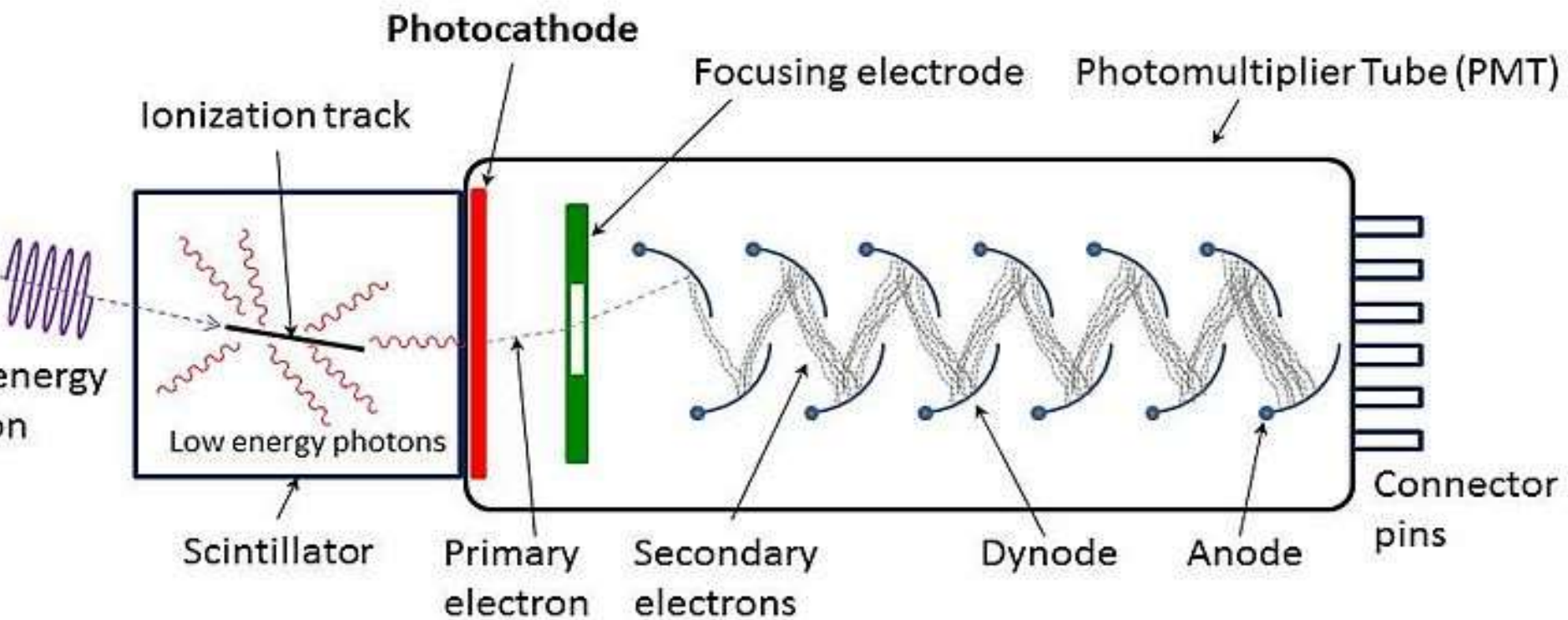

FIGURE 10

INSTRUMENTS

The most common types are:-

- ❑ Single beam (filter) fluorimeter
- ❑ Double beam (filter)fluorimeter
- ❑ Spectrofluorimeter(double beam)



- Instruments:-

- **Single beam filter fluorimeter**

It contains tungsten lamp as a source of light and has an optical system consists of primary filter.

- ✓ The emitted radiations is measured at 90° by using a secondary filter and detector. **Primary filter absorbs visible radiation and transmit uv radiation which excites the molecule present in sample cell.**
- ✓ In stead of 90° if we use 180° geometry as in colorimetry secondary filter has to be highly efficient other wise both the unabsorbed uv radiation and fluorescent radiation will produce detector response and give false result.



- Single beam instruments are simple in construction cheaper and easy to operate.

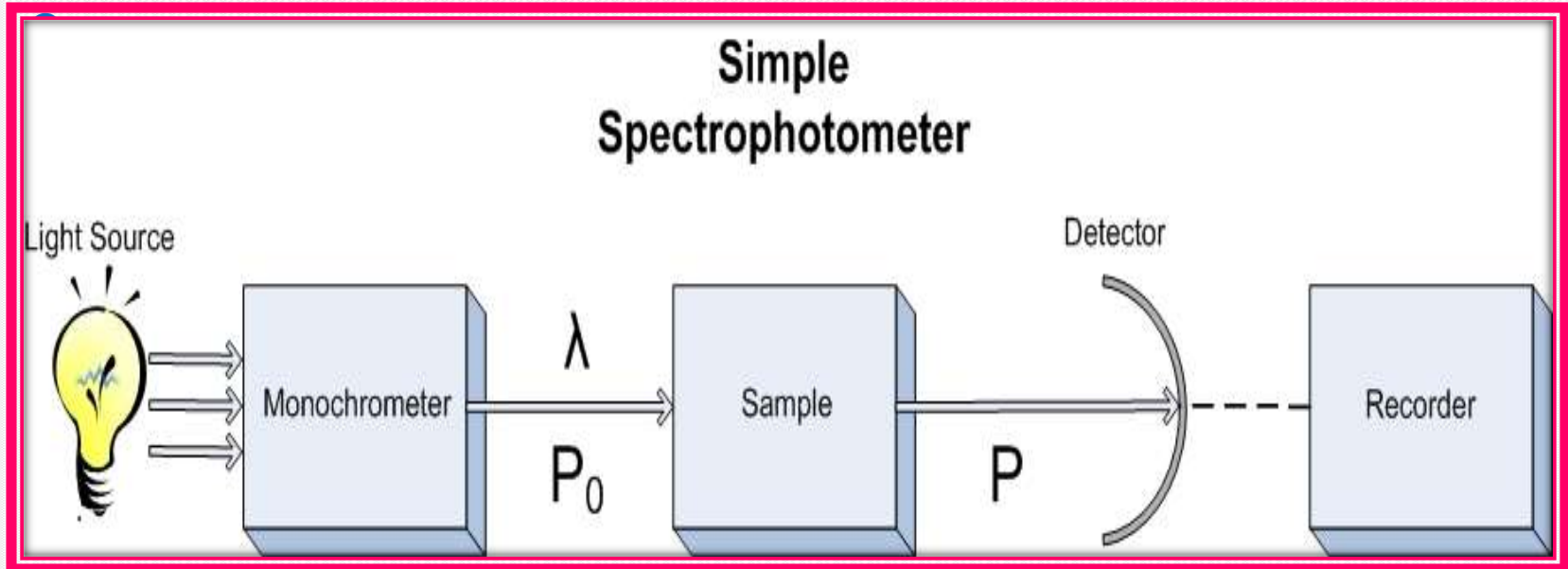

FIGURE 11



- **In double beam fluorimeter:-**it is similar to single beam except that the **two incident beams from a single light source pass through primary filters separately and fall on the another reference solution.** Then the emitted radiations from the sample or reference sample pass separately through secondary filter and produce response combinly on a detector.



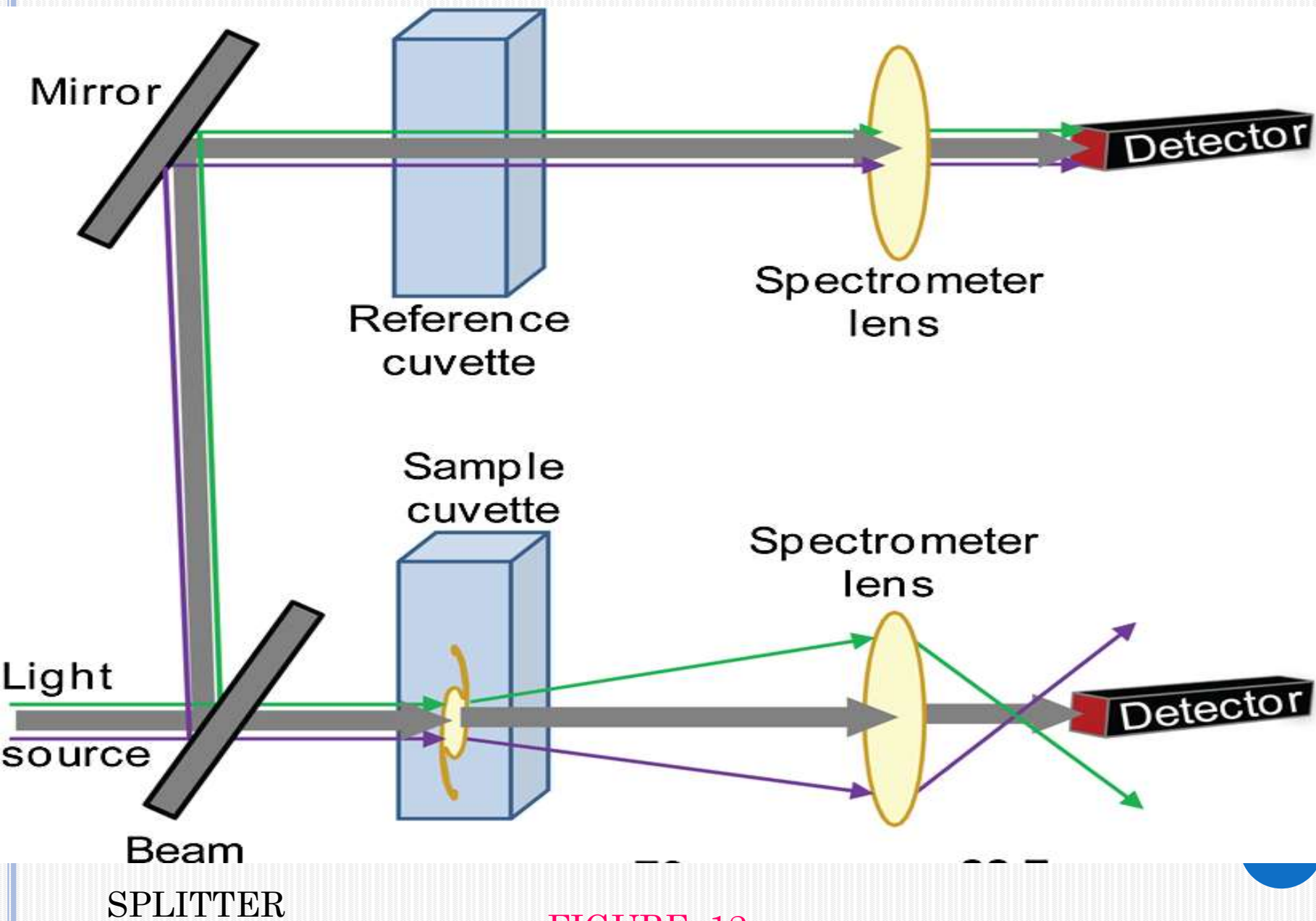
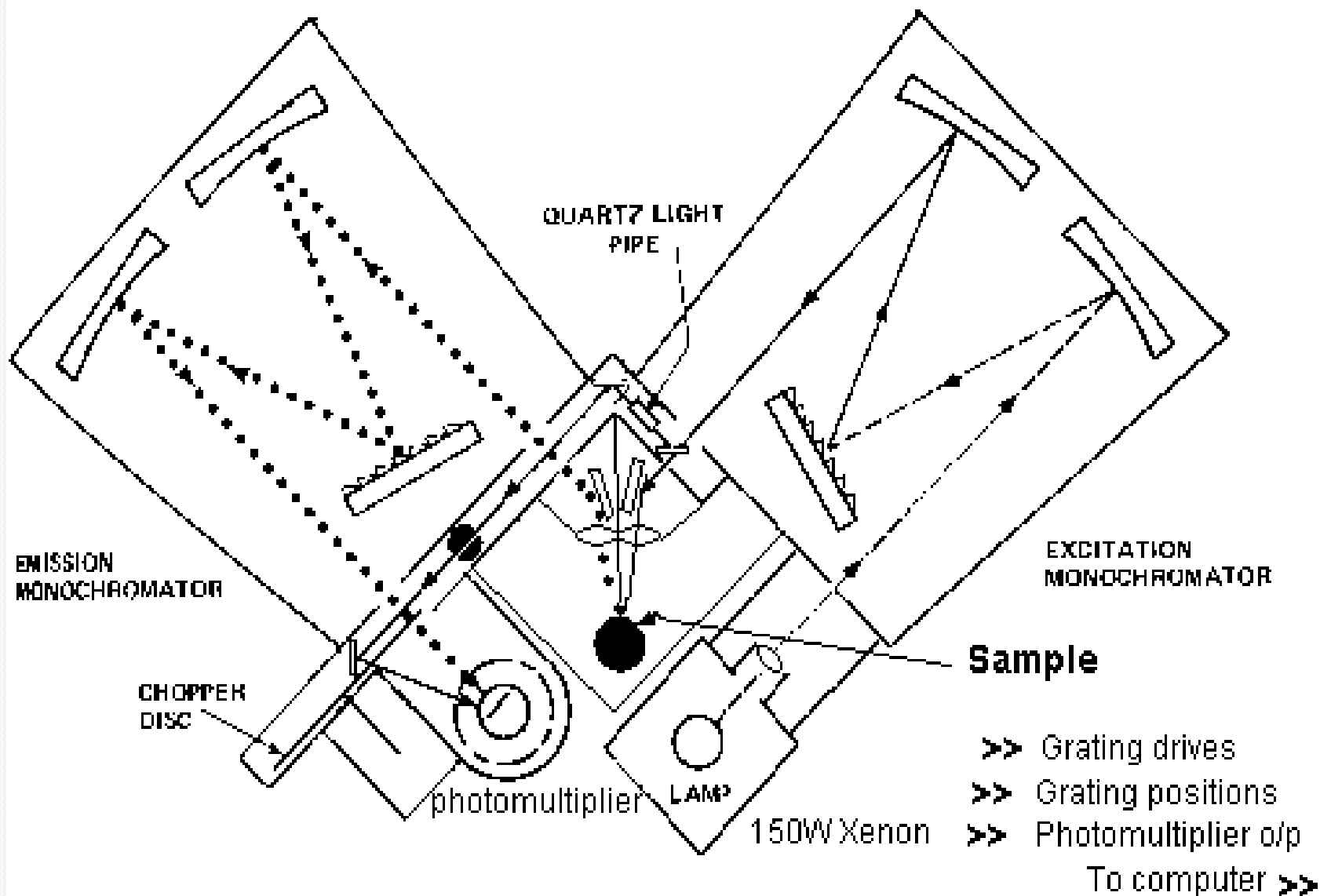

FIGURE 12

- **In spectrofluorimeter:-**
- In this primary filter in double beam fluorimeter is replaced by **excitation monochromator** and the secondary filter is replaced by **emission monochromator**.
- Incident beam is split into sample and reference beam by using beam splitter.





Fluorescence Spectrometer

FIGURE 13

APPLICATIONS

- 1) Determination of inorganic substances.
 Al^{3+} , Li^+ , Zn^{2+}
- 2) Determination of thiamine HCl.
- 3) Determination of phenytoin.
- 4) Determination of indoles, phenols, & phenothiazines
- 5) Determination of naphthols, proteins, plant pigments and steroids.
- 6) Fluorimetry, nowadays can be used in detection of impurities in nanogram level better than absorbance spectrophotometer with special emphasis in determining components of sample at the end of chromatographic or capillary column.



- Determination of ruthenium ions in presence of other platinum metals.
- Determination of boron in steel, aluminum in alloys, manganese in steel.
- Determination of boron in steel by complex formed with benzoin.
- Estimation of cadmium with 2-(2 hydroxyphenyl) benzoxazole in presence of tartarate .
- Respiratory tract infections.



S.No	Name of the compound	Experimental conditions/ PH	Emission wavelength
1	Adrenaline	1	335
2	Cynacobalamine	7	305
3	Riboflavin	6	520
4	Morphine	7	350
5	Hydrocortisone	Acidic	520
6	Pentobarbitone	13	440
7	Amylobarbitone	14	410

Table 1



Conclusion :

- Fluorimetric methods are not useful in qualitative analysis ,and much used in quantitative analysis.
- Fluorescence is the most sensitive analytical techniques.
- Detection studies will increase the development of fluorescence field.



References :

- **SKOOG ,Principles of Instrumental Analysis.**
- **Practical pharmaceutical chemistry by A.H. BECKETT & J.B.STENLAKE ,volume 2,**
- **B.K.Sharma Instrumental methods of chemical analysis.**
- **A textbook of pharmaceutical analysis by Dr.S.RAVISANKAR.**
- **Google Images**





Thank you