

X – RAY DIFFRACTION (XRD)





Introduction

★ It is a **novel & non destructive** method of chemical analysis and a variety of x –ray techniques are available in practice.

★ These are : **X – Ray Absorption : X-ray diffraction**
 X-ray Fluorescence

★ *X – ray diffraction*

“ Every crystalline substance gives a pattern; the same substance always gives the same pattern; and in a mixture of substances each produces its pattern independently of the others ”

★ The **X-ray diffraction pattern** of a pure substance is, therefore, like a **fingerprint of the substance**. It is based on the scattering of x-rays by crystals.

★ **Definition**

The atomic planes of a crystal cause an **incident beam of X-rays to interfere with one another** as they leave the crystal. The phenomenon is called X-ray diffraction.





What is X-ray Diffraction ?

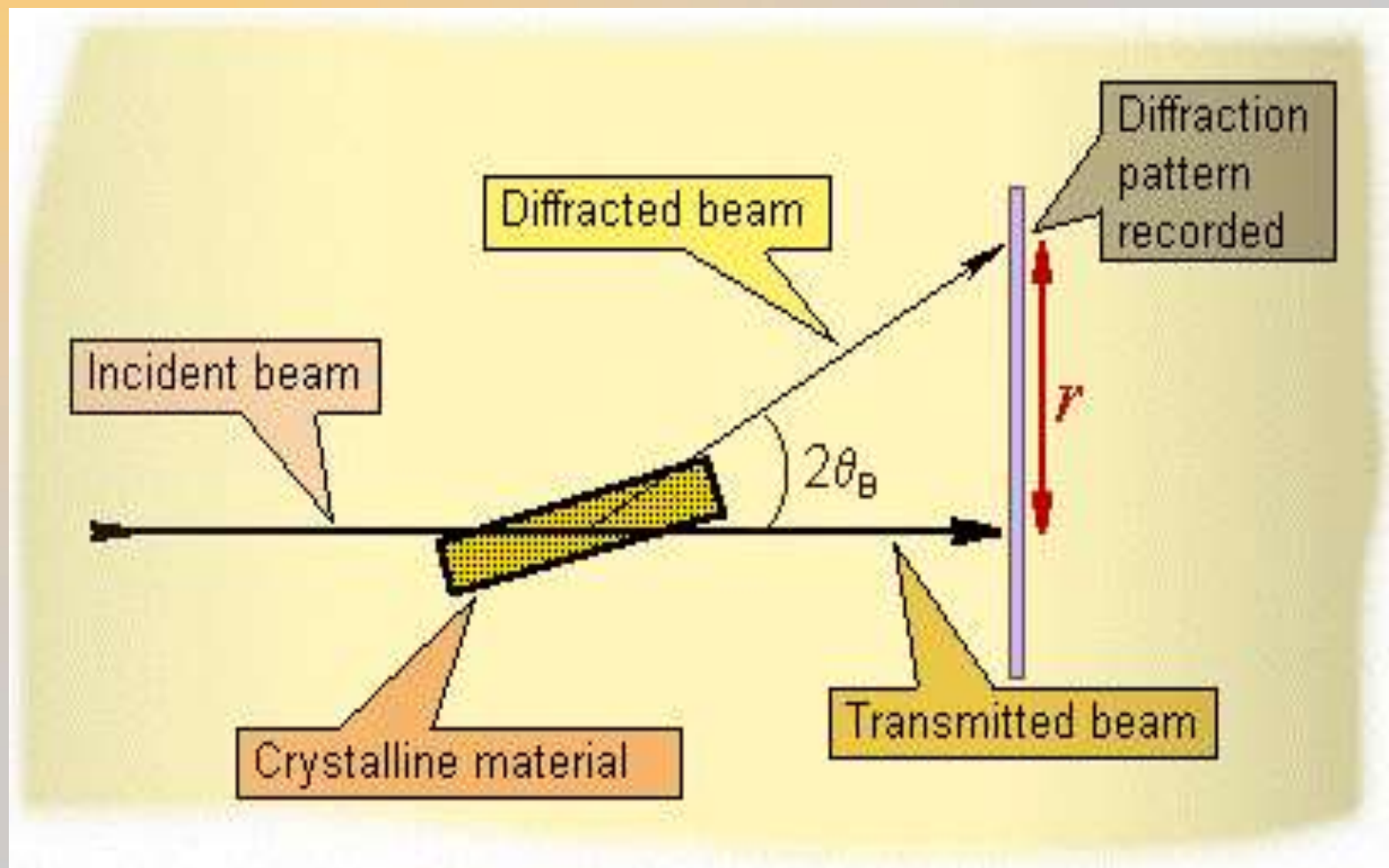



Why XRD?

-
- ★ Measure the average spacing's between **layers or rows of atoms**
 - ★ Determine the **orientation of a single crystal** or grain
 - ★ Find the crystal structure of an unknown material
 - ★ Measure the size, shape and internal stress of small crystalline regions



Effect of sample thickness on the absorption of X-rays

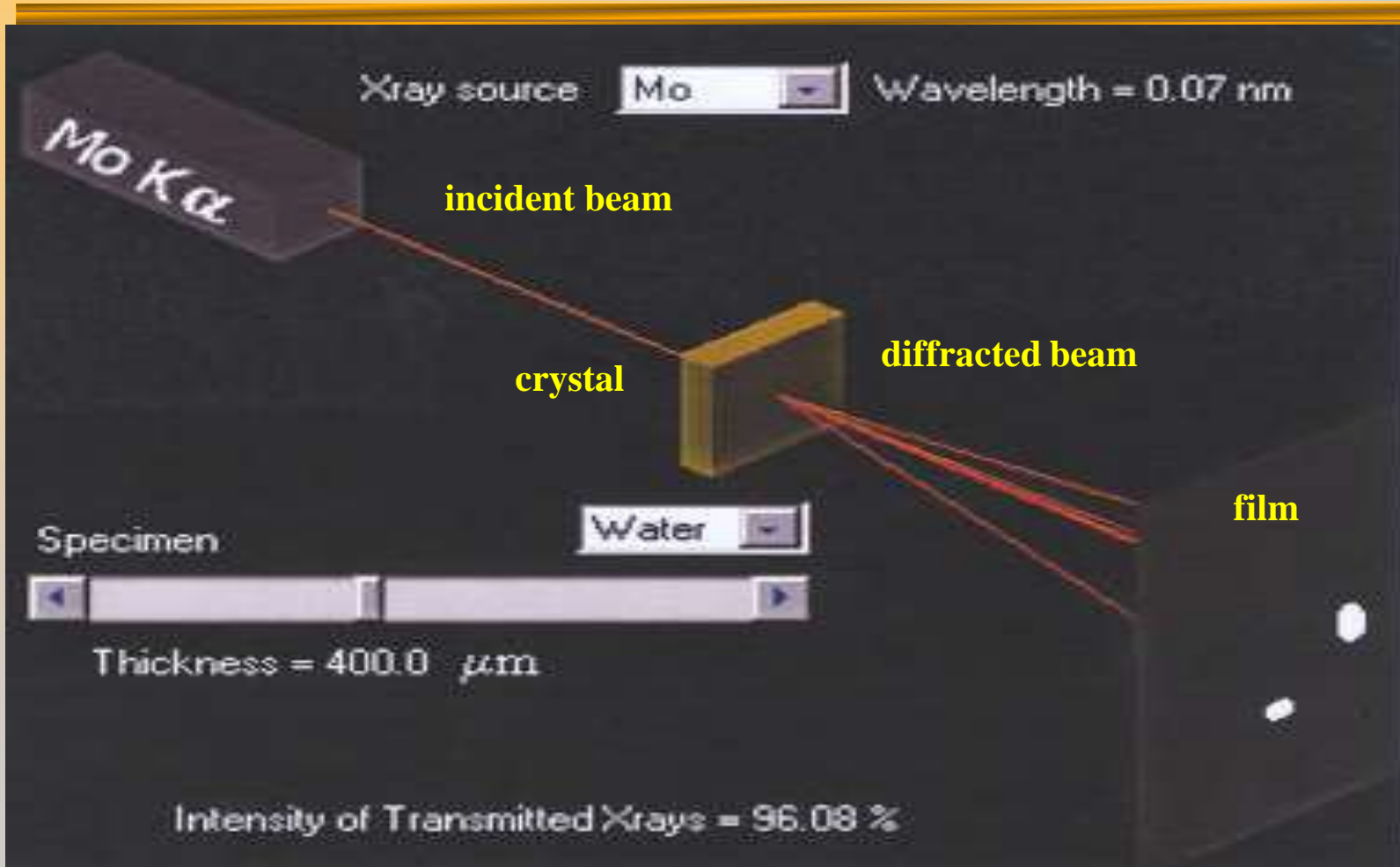



Detection of Diffracted X-rays by Photographic film

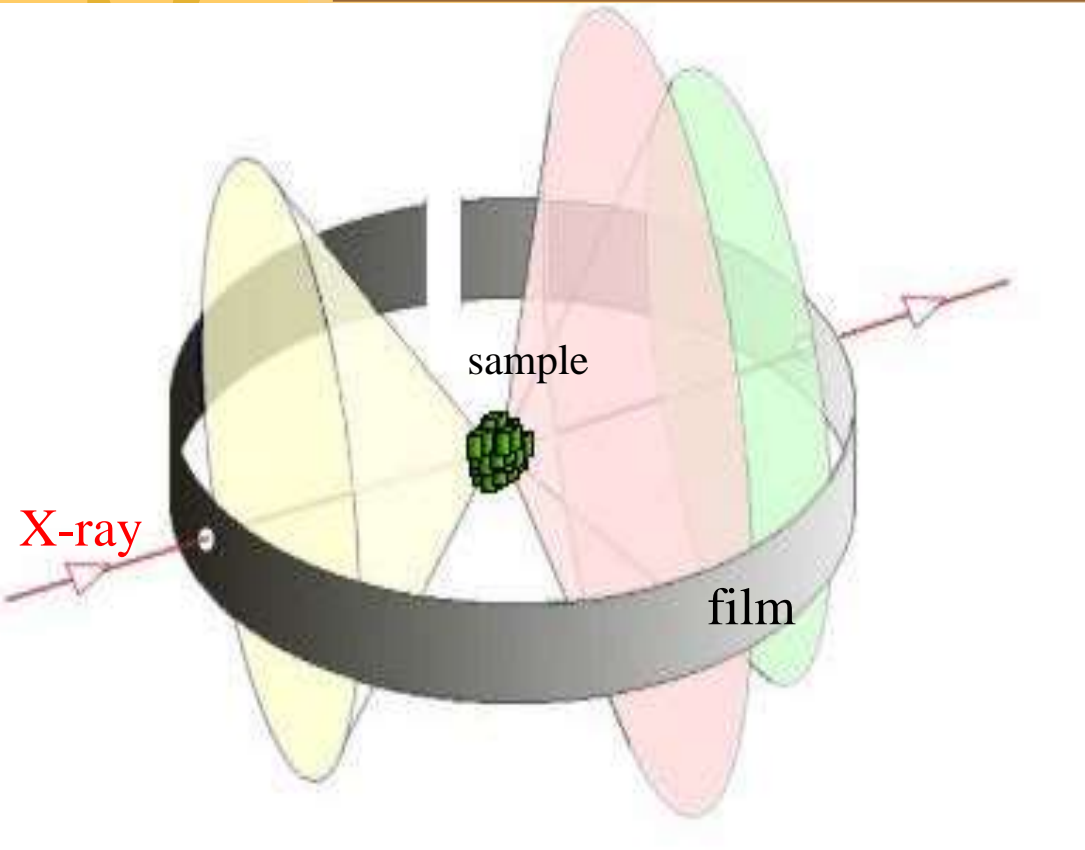

- ★ A sample of some hundreds of crystals (i.e. a powdered sample) show that the diffracted beams form continuous cones. A circle of film is used to record the diffraction pattern as shown. Each cone intersects the film giving diffraction lines. The lines are seen as arcs on the film.

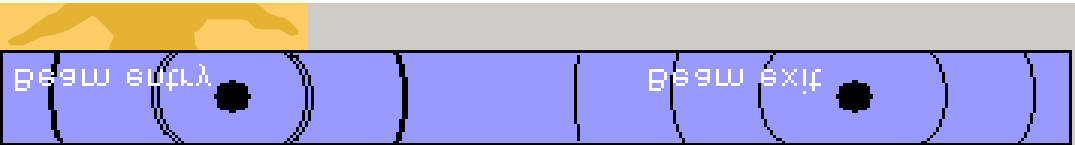



Bragg's Law and Diffraction

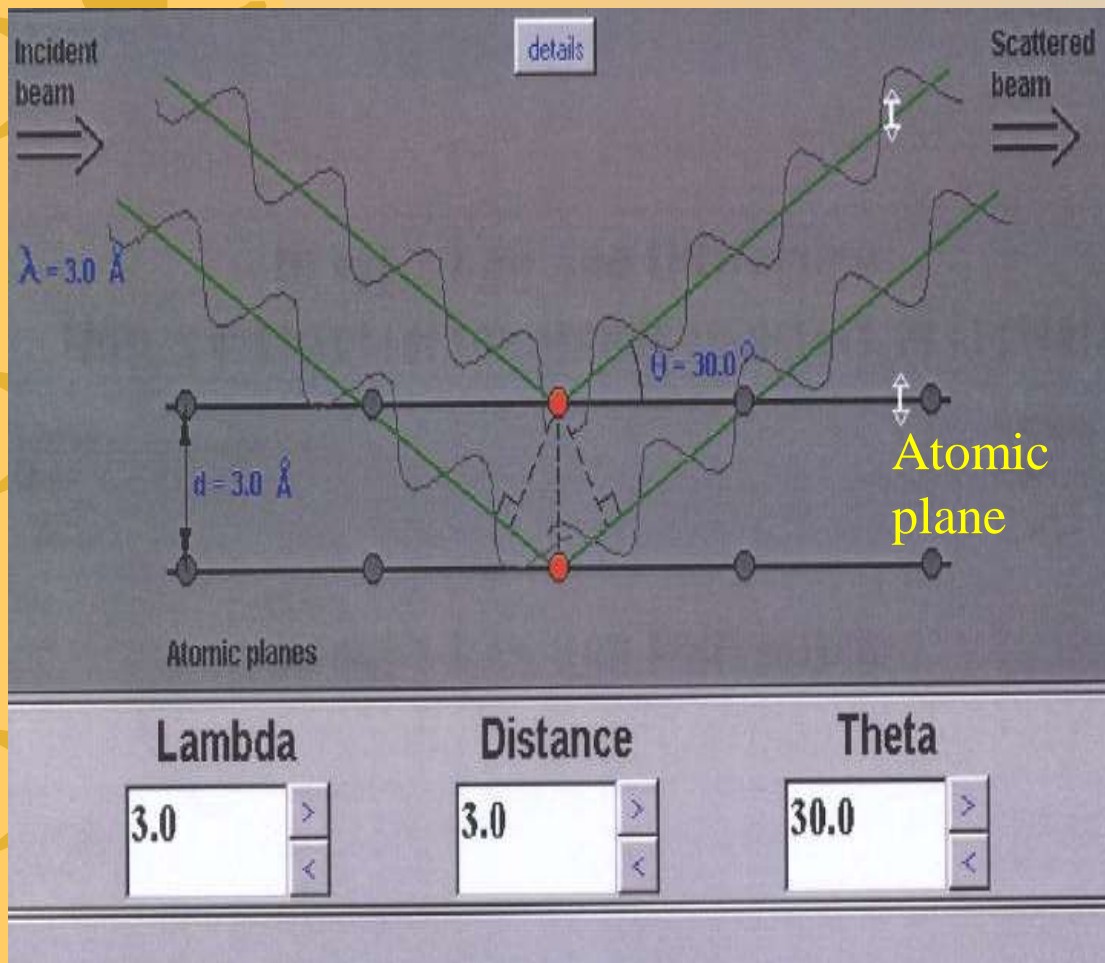

- ★ How waves reveal the atomic structure of crystals
$$N \lambda = 2d \sin\theta$$
$$N = \text{integer}$$
- ★ Diffraction occurs only when Bragg's Law is satisfied
Condition for constructive interference (X-rays 1 & 2) from planes with spacing d



Deriving Bragg's Law: $n \lambda = 2d \sin \theta$

X-ray 1

X-ray 2

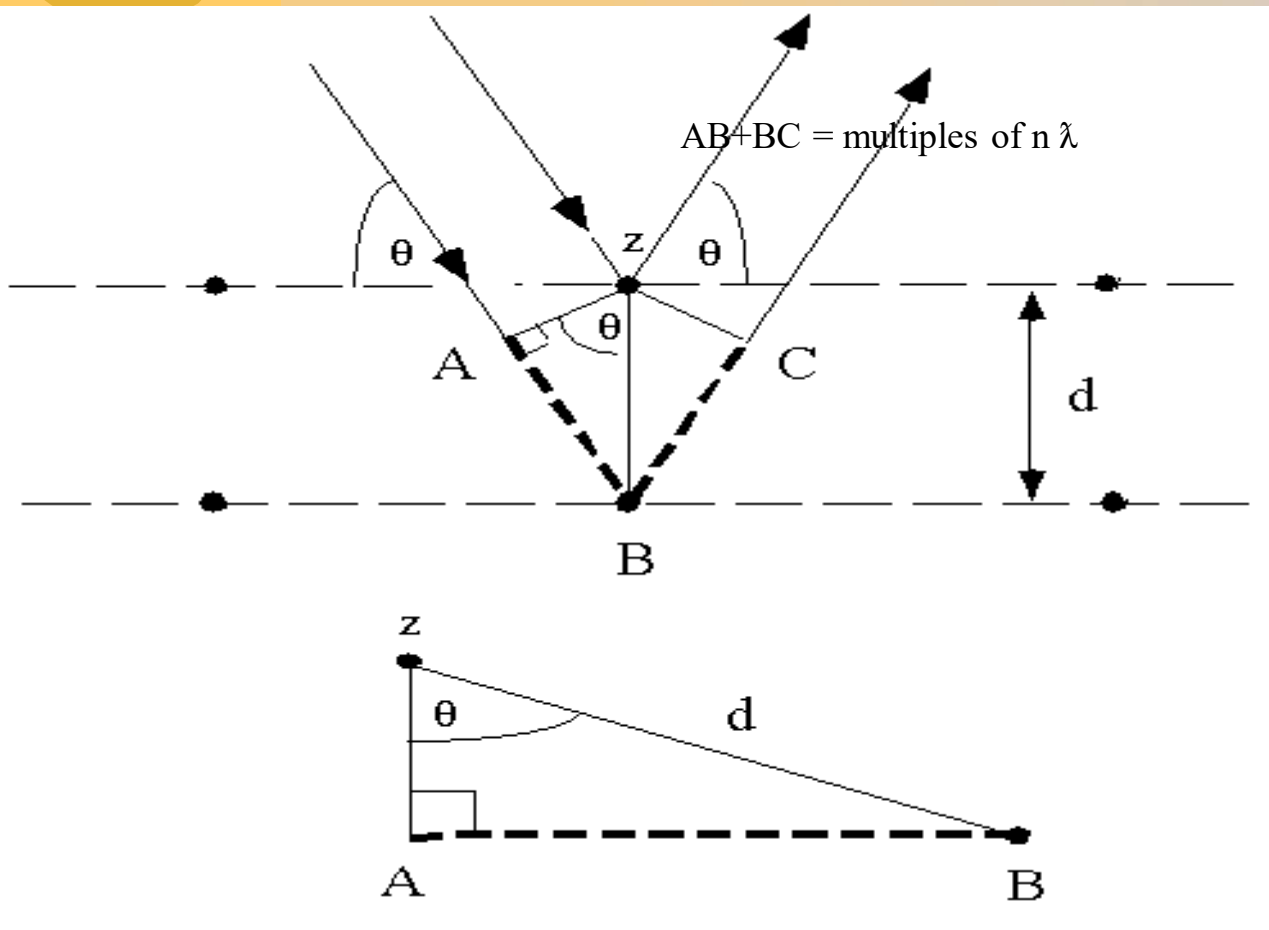

★ Constructive interference
X-ray 2 occurs only when

$$n \lambda = AB + BC$$
$$AB = BC$$
$$n \lambda = 2AB$$
$$\sin \theta = AB/d$$
$$AB = d \sin \theta$$
$$n \lambda = 2d \sin \theta$$



Planes in Crystals-2 dimension

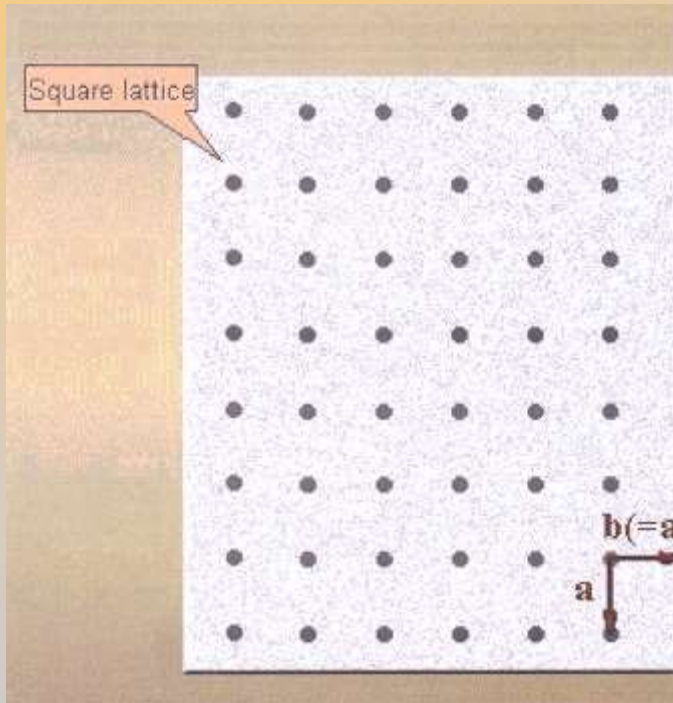

- ★ Different planes have different spacing



Basics of Crystallography

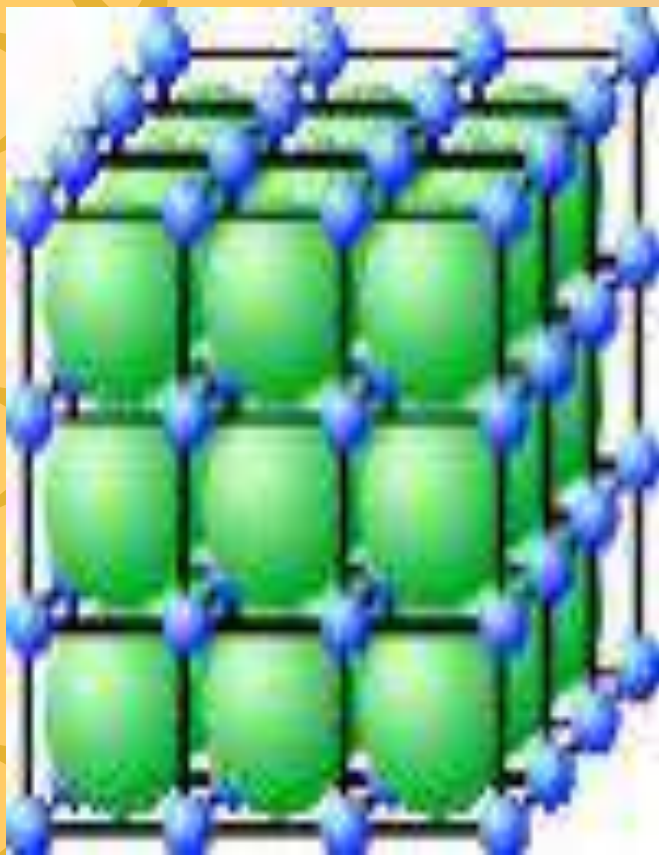

Lattice

- ★ The atoms are arranged in a regular pattern, and there is as smallest volume element that by **repetition in three dimensions** describes the crystal. This smallest volume element is called a **unit cell**.
- ★ Crystals consist of planes of atoms that are spaced a distance d apart, but can be resolved into many atomic planes, each with a different d spacing.
- ★ The dimensions of the unit cell is described by three axes : a , b , c and the angles between them α , β , and γ are lattice constants which can be determined by XRD.



Miller Indices: hkl

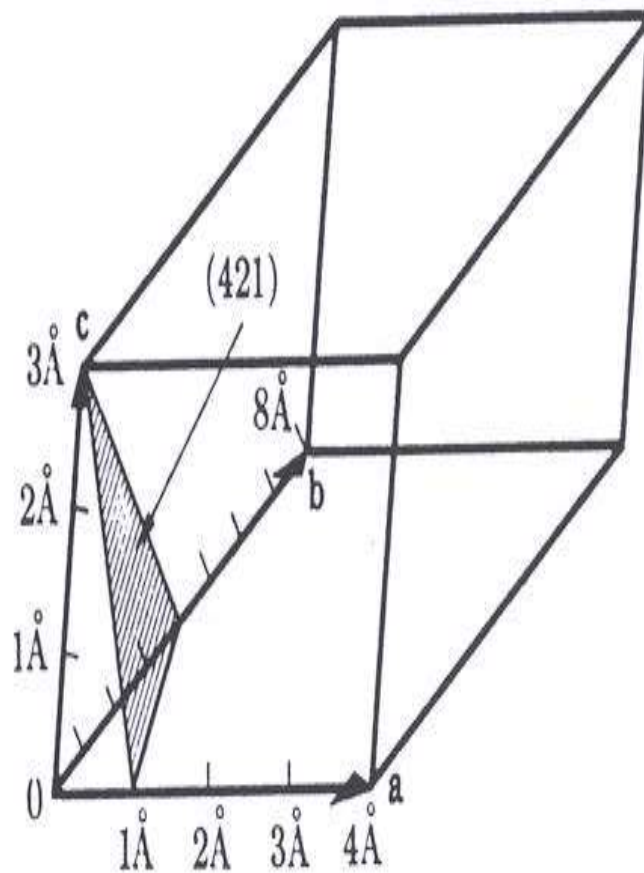
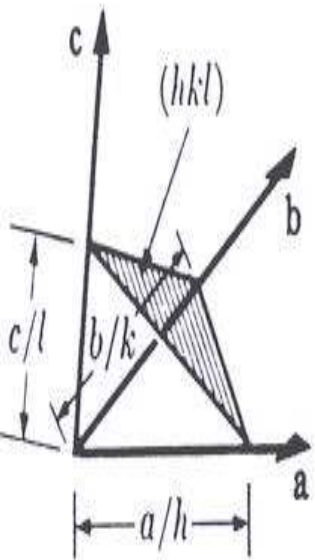

- ★ Miller indices-the reciprocals of the fractional intercepts which the plane makes with crystallographic axis
- ★ Axial length 4Å 8Å 3Å
- ★ Intercept lengths 1Å 4Å 3Å
- ★ Fractional intercepts $\frac{1}{4}$ $\frac{1}{2}$ 1
- ★ Miller indices $4\ 2\ 1$
 $h\ k\ l$

Production of X-rays

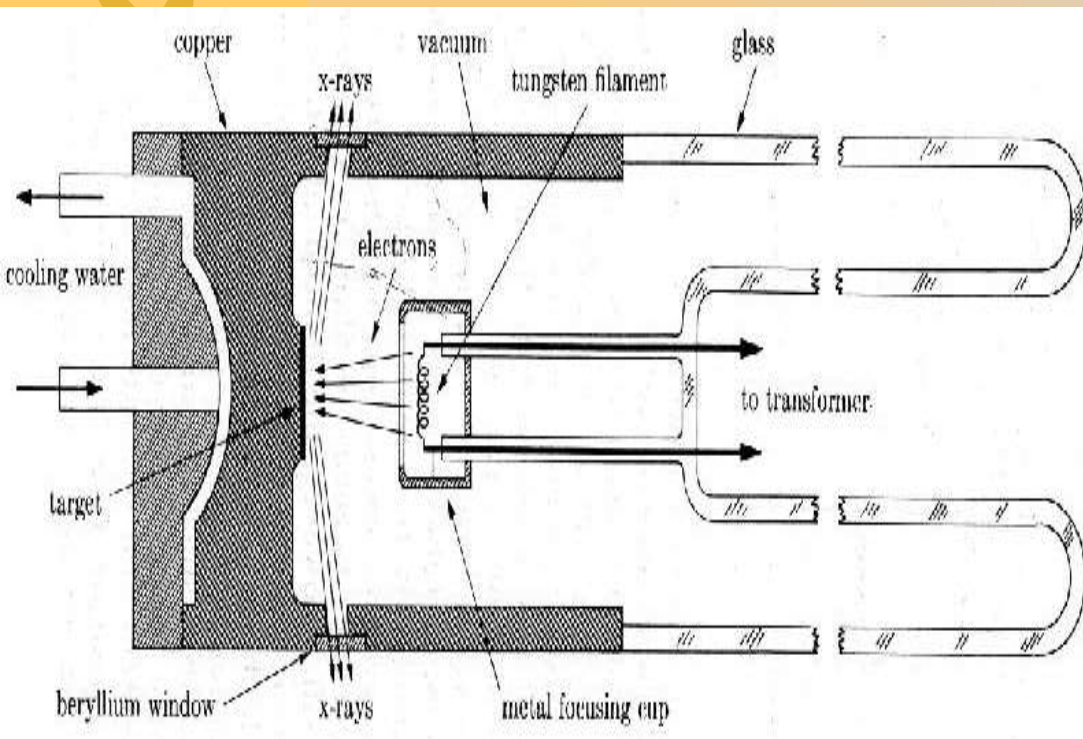

- ★ X-rays are produced whenever high-speed electrons collide with a metal target.
- ★ A source of electrons – hot W filament, a high accelerating voltage between the cathode (W) and the anode and a metal target, *Cu, Al, Mo, Mg*.
- ★ The anode is a water-cooled block of Cu containing desired target metal.



Specimen Preparation



- ★ Powders:

$0.1\ \mu\text{m}$ < particle size < $40\ \mu\text{m}$
Peak broadening less diffraction occurring



- ★ Bulks: smooth surface after polishing, specimens should be thermal annealed to eliminate any surface deformation induced during polishing.





A Modern Automated X-ray Diffractometer

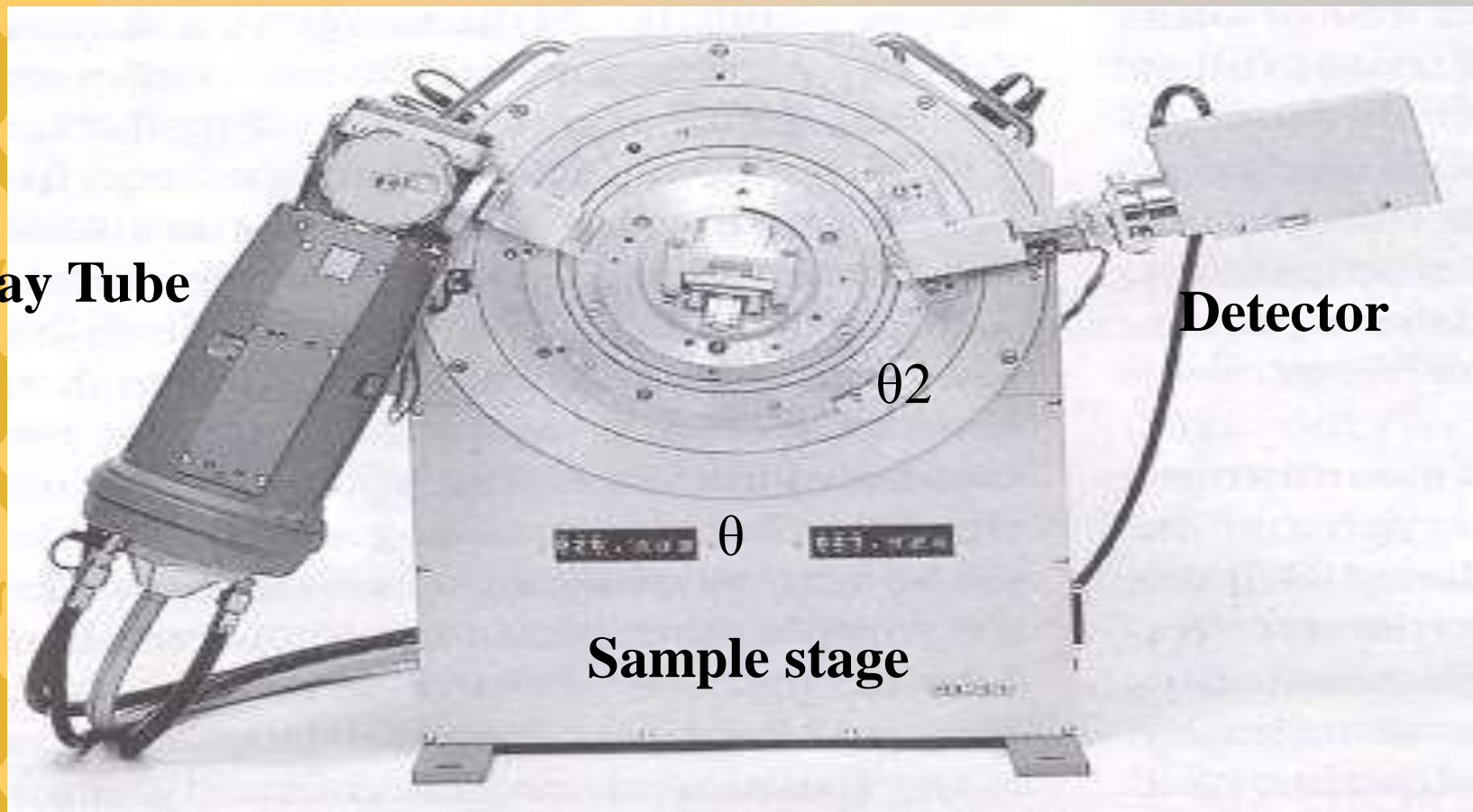

X-ray Tube

Detector

Sample stage

Cost: \$560K to 1.6M



Basic components & Features of XRD



★ Production



★ Diffraction



★ Detection



★ Interpretation

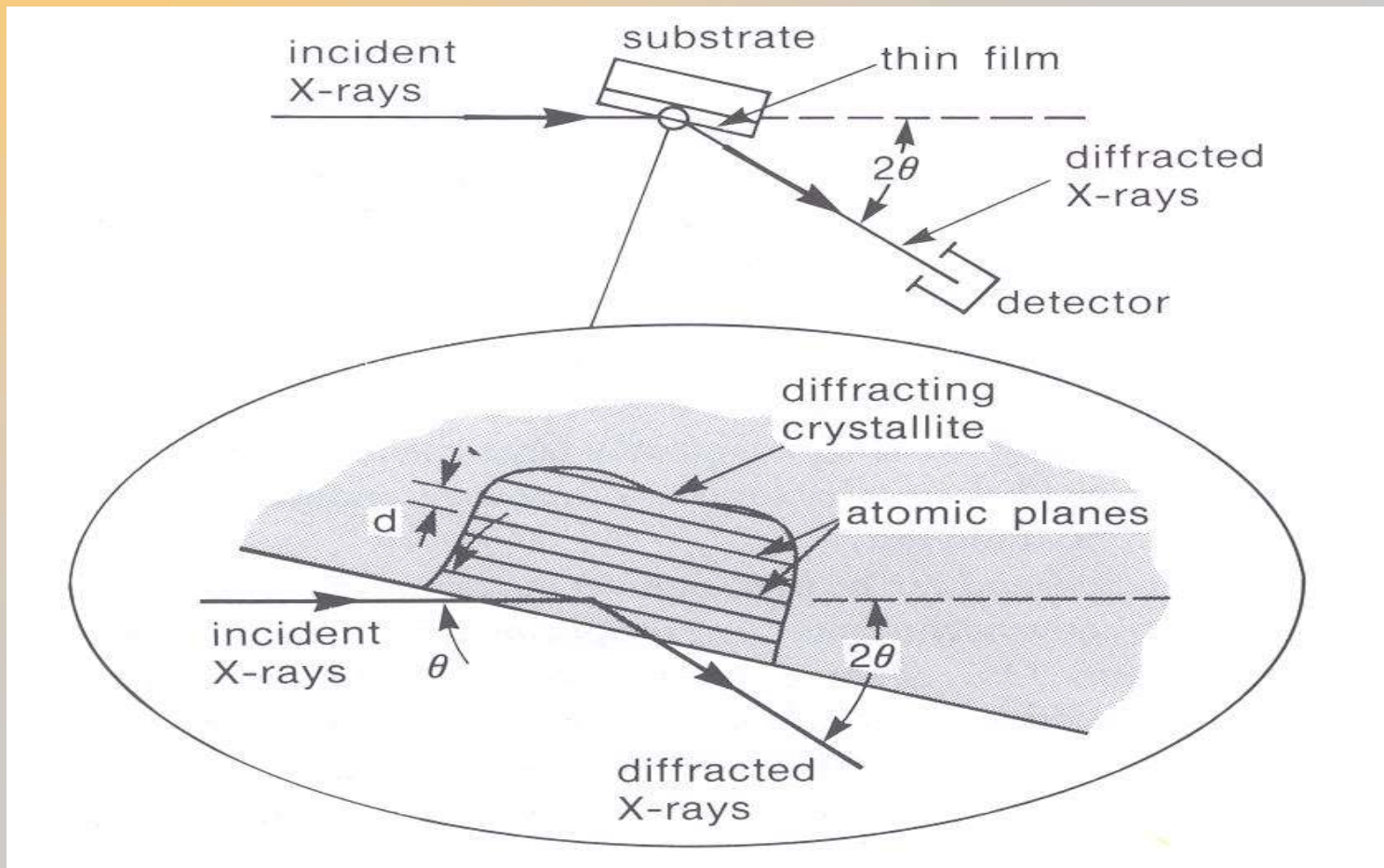



Detection of Diffracted X-rays by a Diffractometer

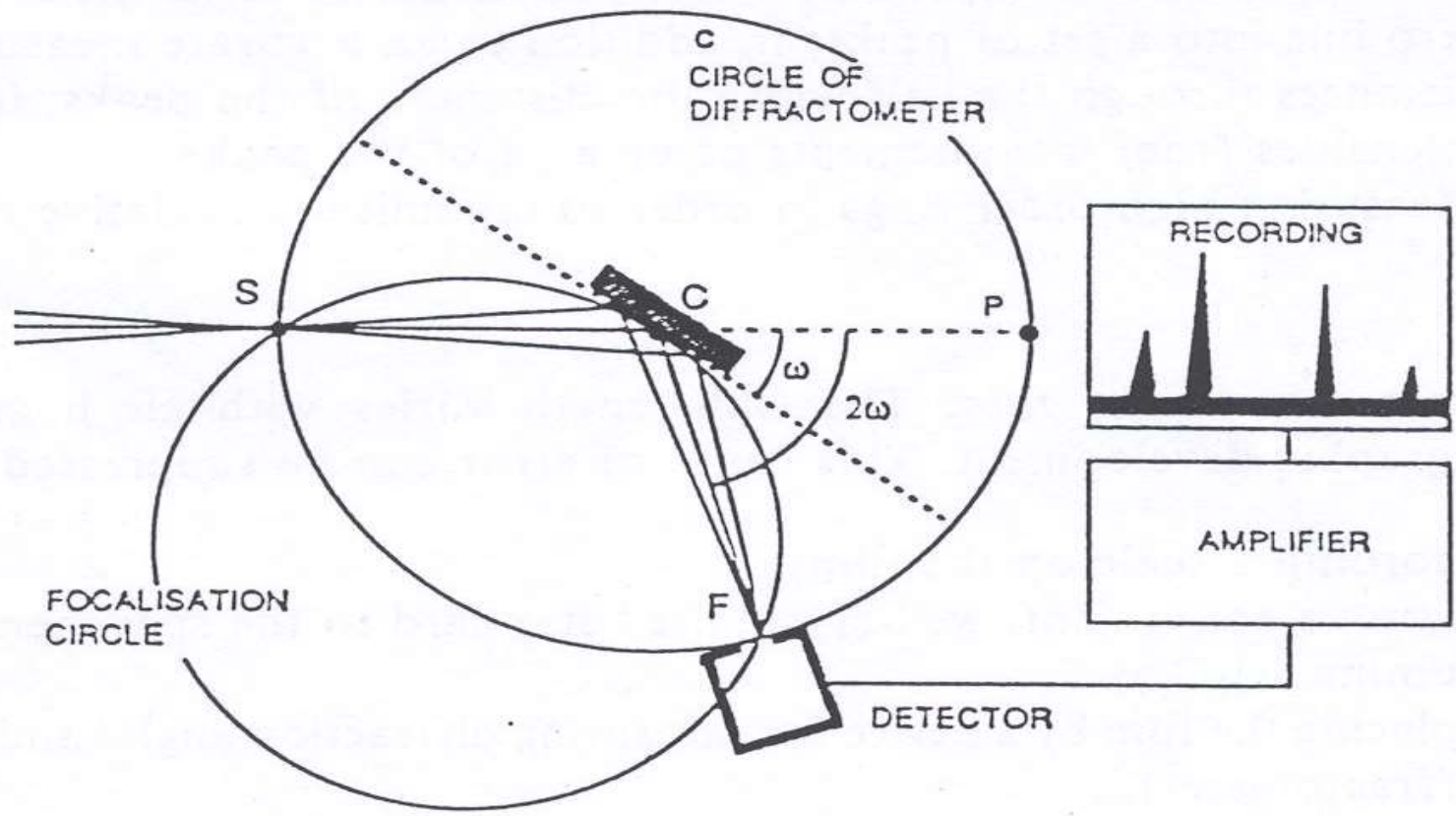

Bragg - Brentano Focus Geometry, Cullity



XRD Pattern of NaCl Powder

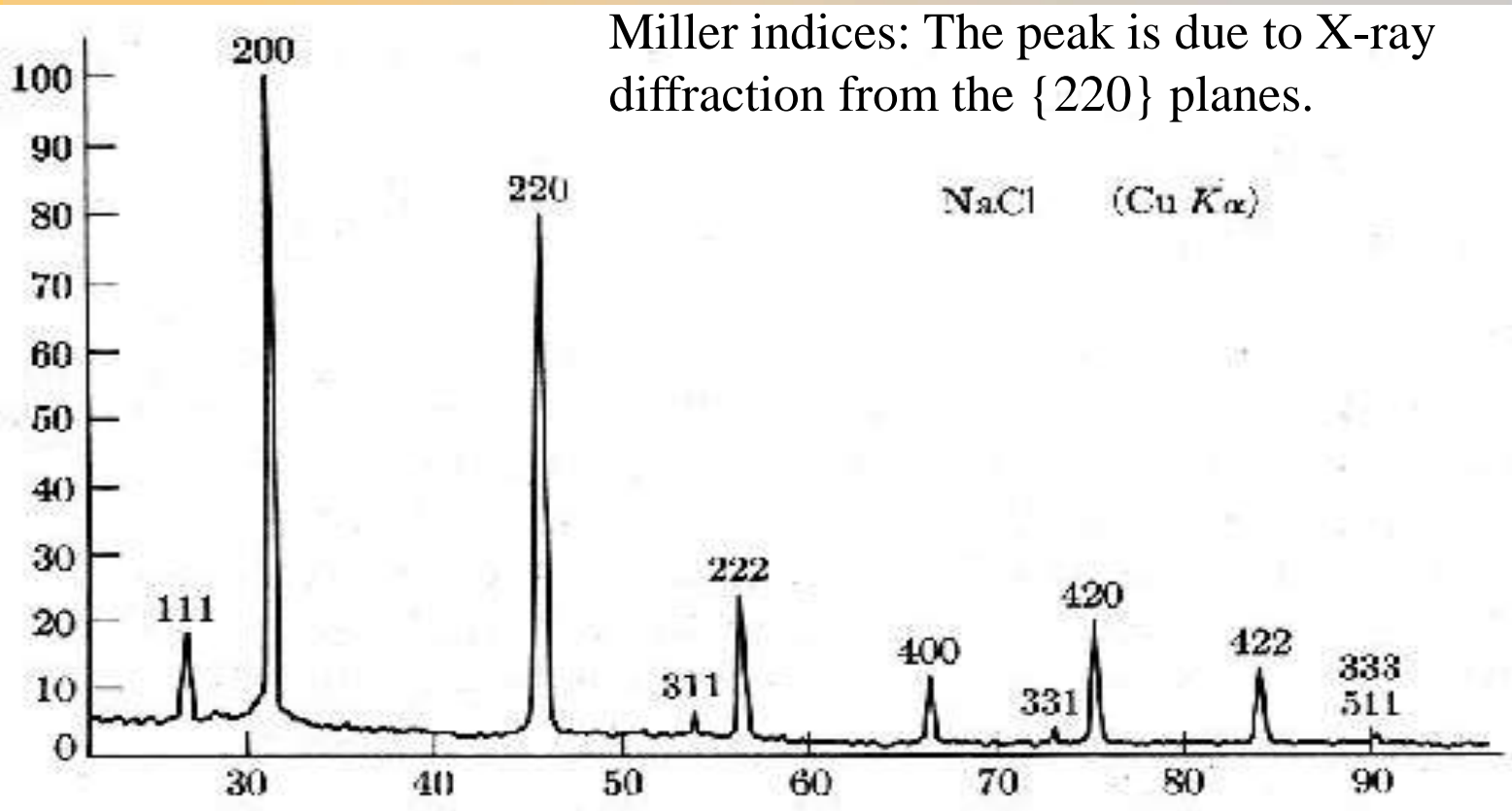

Diffraction angle 2θ (degrees)



Significance of Peak Shape in XRD

- ★ Peak position
- ★ Peak width
- ★ Peak intensity

Important for

- ★ Particle or grain size
- ★ Residual strain

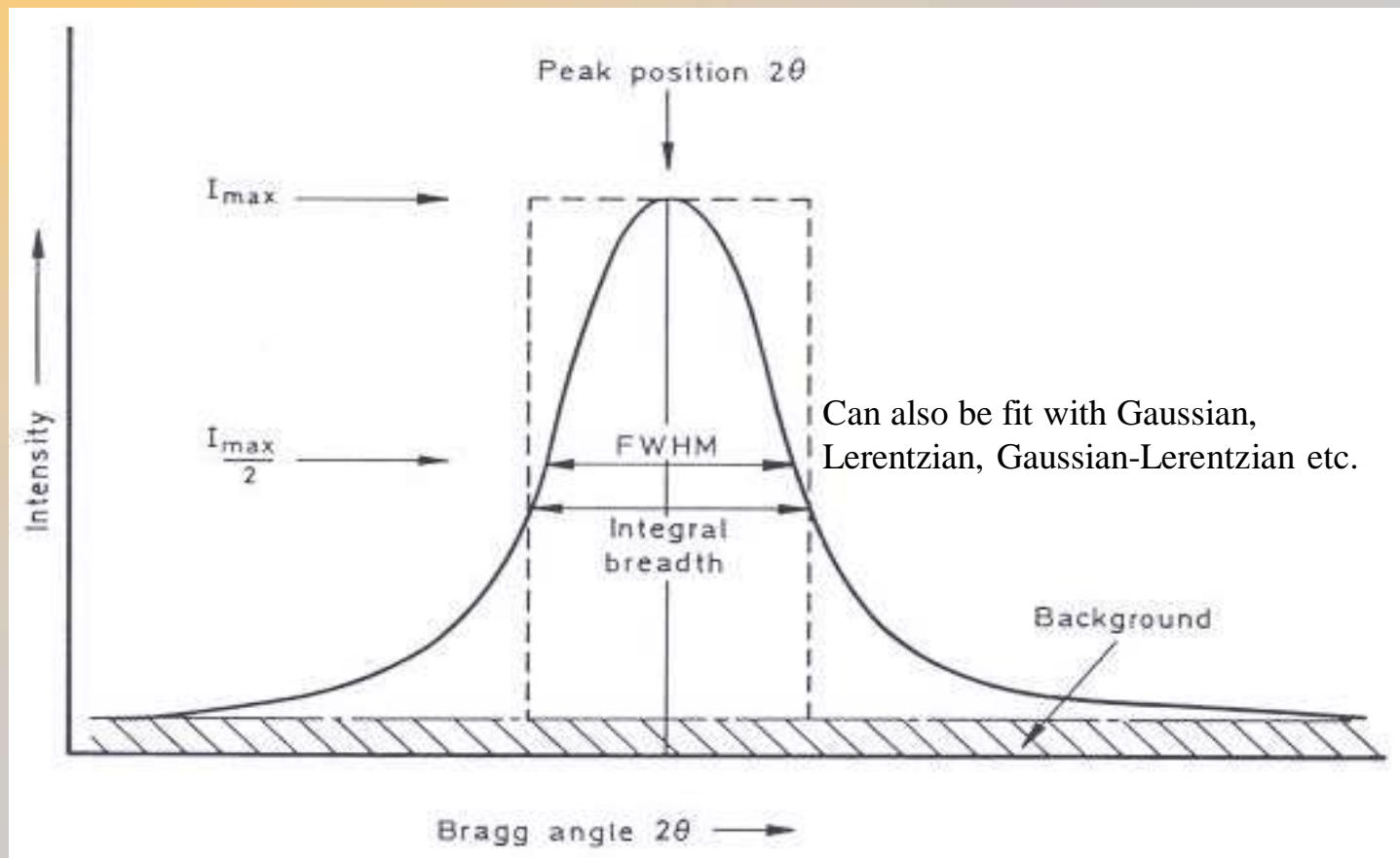



Applications of XRD

★ XRD is a non destructive technique to identify **crystalline phases** and **orientation**

- Obtain XRD pattern ; Measure d-spacings ; Obtain integrated intensities ;
- Compare data with known standards in the JCPDS file

(JCPDS data is used to fitting the plane values of synthesized nanomaterials. JCPDS data have **theta, intensity counts, d-spacing values, lattice parameter values**. the intensity counts are used to find the **texture coefficient** of thin films and nanomaterials. d-spacing values are used to find the **morphological index of the nanomaterials**. JCPDS data's have all diffraction patterns of chemical systems. it is more useful to find the crystal structure of the nanomaterials.)





Applications of XRD

- ★ The electron density and accordingly, the position of the atoms in complex structures, such as **penicillin** may be determined from a comprehensive mathematical study of the x-ray diffraction pattern.
- ★ The elucidation of structure of penicillin by xrd paved the way for the later synthesis of penicillin.
- ★ The powder xrd pattern may be thought of as finger print of the single crystal structure, and it may be used to conduct qualitative and quantitative analysis.
- ★ Xrd can also be used to determine whether the compound is solvated or not





Applications of XRD

- ★ Particle size determination by applying the relation.

$$v = V \cdot \delta\theta \cdot \cos \theta / 2n$$

Where v = the volume or size of an individual crystalline

V = the total volume of the specimen irradiated

n = the number of spots in a deffraction ring at a Bragg angle θ

$\delta\theta$ = the divergence of the X –ray beam

- ★ Determination of Cis-Trans isomerism
- ★ It is used to assess the weathering and degradation of natural and synthetic , minerals.
- ★ Tooth enamel and dentine have been examined by xrd.
- ★ State of anneal in metals





Synchrotron

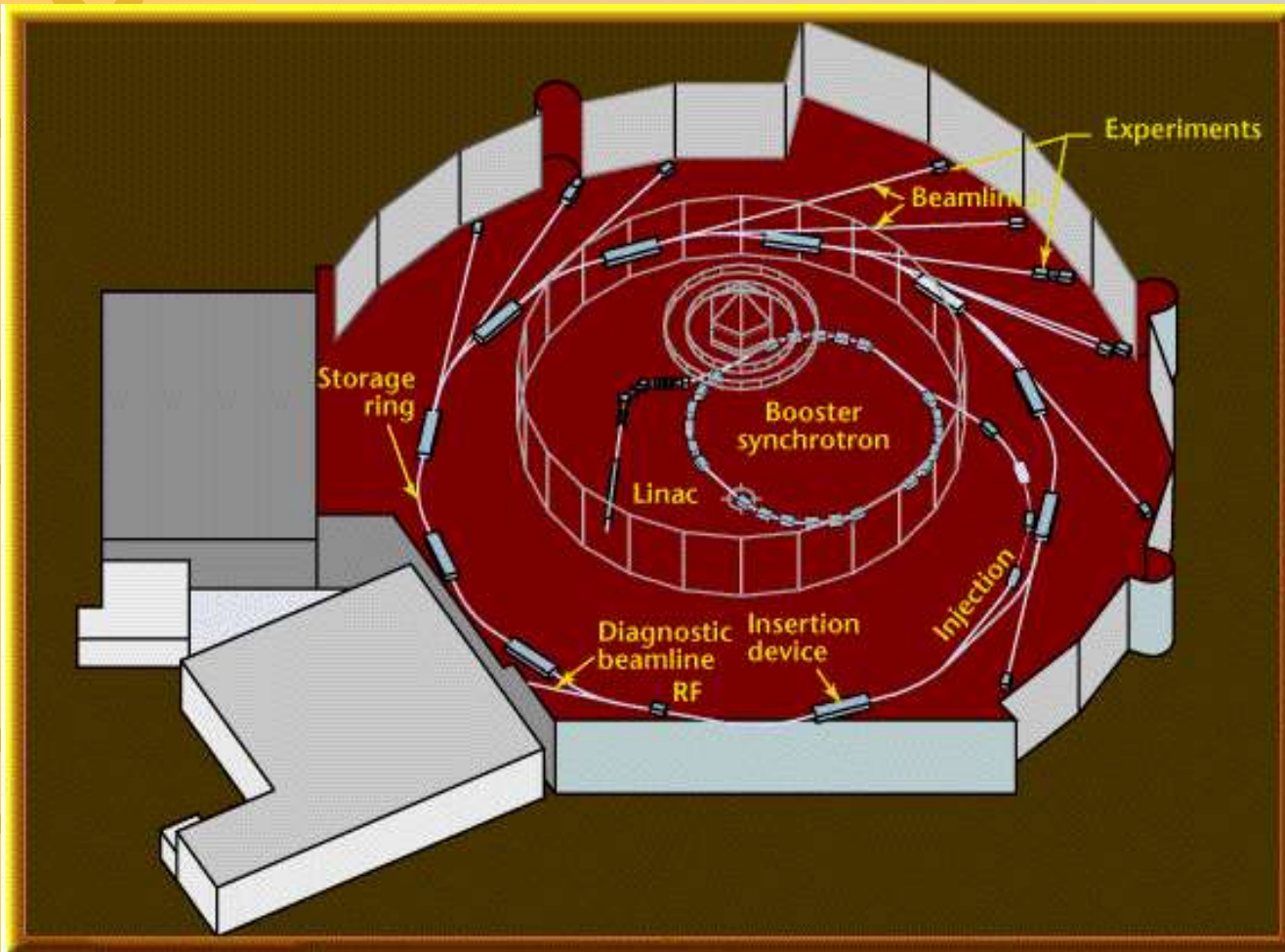

- ★ A synchrotron is a particle acceleration device which, through the use of bending magnets, causes a charged particle beam to travel in a circular pattern.



Advantages of using synchrotron radiation



- ★ Detecting the presence and quantity of trace elements
- ★ Providing images that show the structure of materials
- ★ Producing X-rays with 10⁸ more brightness than those from normal X-ray tube (tiny area of sample)
- ★ Having the right energies to interact with elements in light atoms such as carbon and oxygen
- ★ Producing X-rays with wavelengths (tunable) about the size of atom, molecule and chemical bonds



Instrumental Sources of Error

- ★ Specimen displacement
- ★ Instrument misalignment
- ★ Error in zero 2θ position
- ★ Peak distortion due to K alfa 2 and K beta wavelengths





Conclusions

- ★ Non-destructive, fast, easy sample preparation
- ★ High-accuracy for d-spacing calculations
- ★ Can be done in-situ
- ★ Single crystal, poly, and amorphous materials
- ★ Standards are available for thousands of material systems





**THANK
YOU!**