

POINTS TO BE COVERED...

- Introduction
- Objectives
- System Hardware Design
- Programmable Logic
- Advantages
- Conclusions
- References

INTRODUCTION

- Monsoon dependent Indian Agriculture
- Automatic Irrigation
- An over-irrigation and under-irrigation
- Soil moisture, air humidity, temperature and water level in the soil are wirelessly transmitted using **wireless technology** for better production.

A pair of hands is shown from a top-down perspective, gently cupping a small globe of the Earth. The globe is centered and features a green and white color scheme, with the continents in white and the oceans in green. The hands are positioned symmetrically on either side of the globe, with the fingers pointing towards the center. The background is a soft, out-of-focus green, suggesting a natural, outdoor setting with sunlight filtering through. The overall image conveys a message of environmental stewardship and global unity.

WELCOME

A
Seminar
on
SMART IRRIGATION SYSTEM

Submitted To
Prof. P. R. Juvekar

Presented By
Miss. Mulik S. D.
(SHE-2013/023)

POINTS TO BE COVERED...

- Introduction
- Objectives
- System Hardware Design
- Programmable Logic
- Advantages
- Conclusions
- References

INTRODUCTION

- Monsoon dependent Indian Agriculture
- Automatic Irrigation
- An over-irrigation and under-irrigation
- Soil moisture, air humidity, temperature and water level in the soil are wirelessly transmitted using **wireless technology** for better production.

OBJECTIVES

- To save water and reduce human intervention in the agriculture field
- Continuously Monitoring the status of sensors and provide signal for taking necessary action
- To get the output of soil water sensor and provide water to crop
- To observe other parameters for better yield

SYSTEM HARDWARE DESIGN

The Hardware consists of two sections:

1. Transmitter section
2. Receiver section

The system also consist of microcontroller 328P, GSM module, LCD, and zigbee module.

1. Transmitter

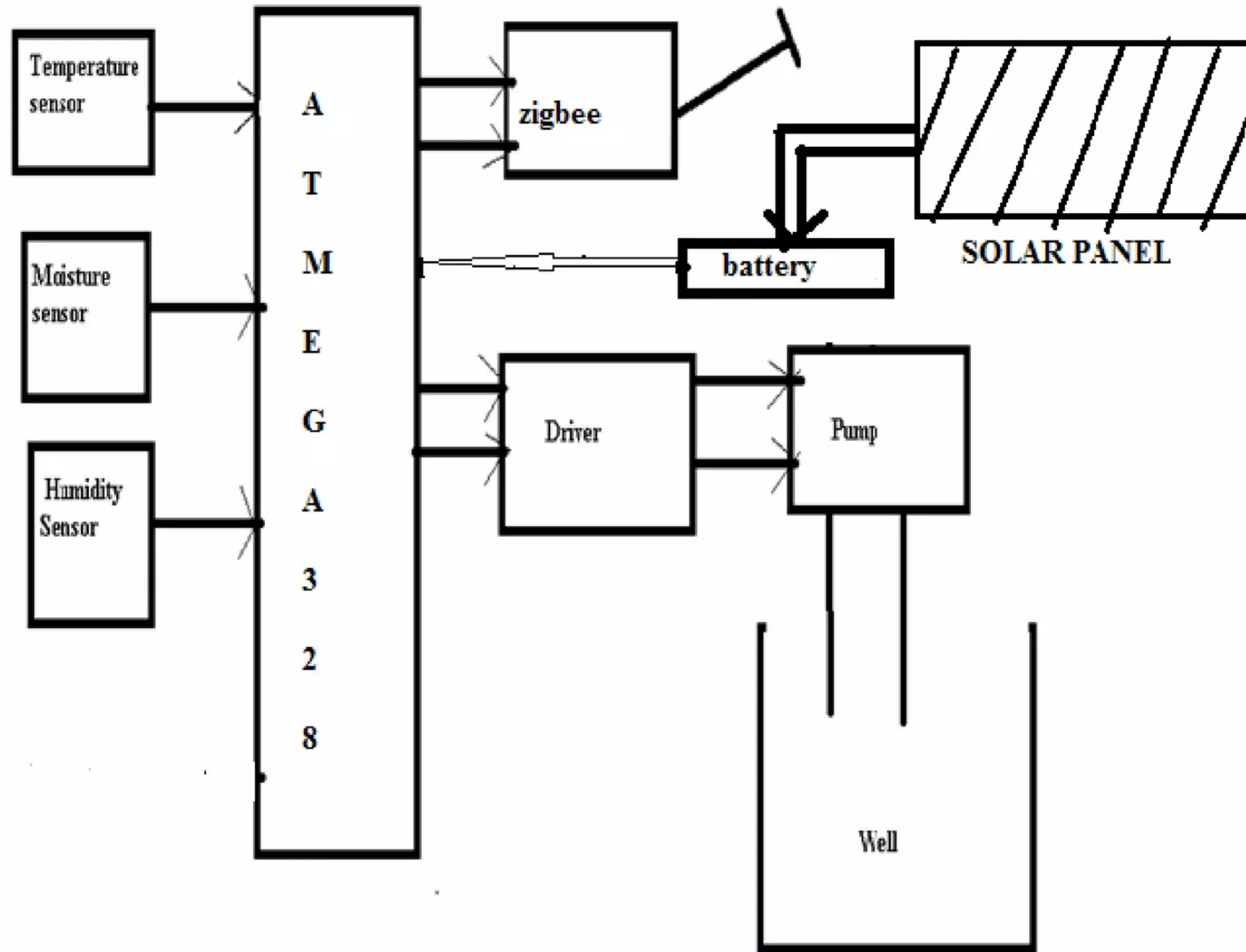

2. Receiver

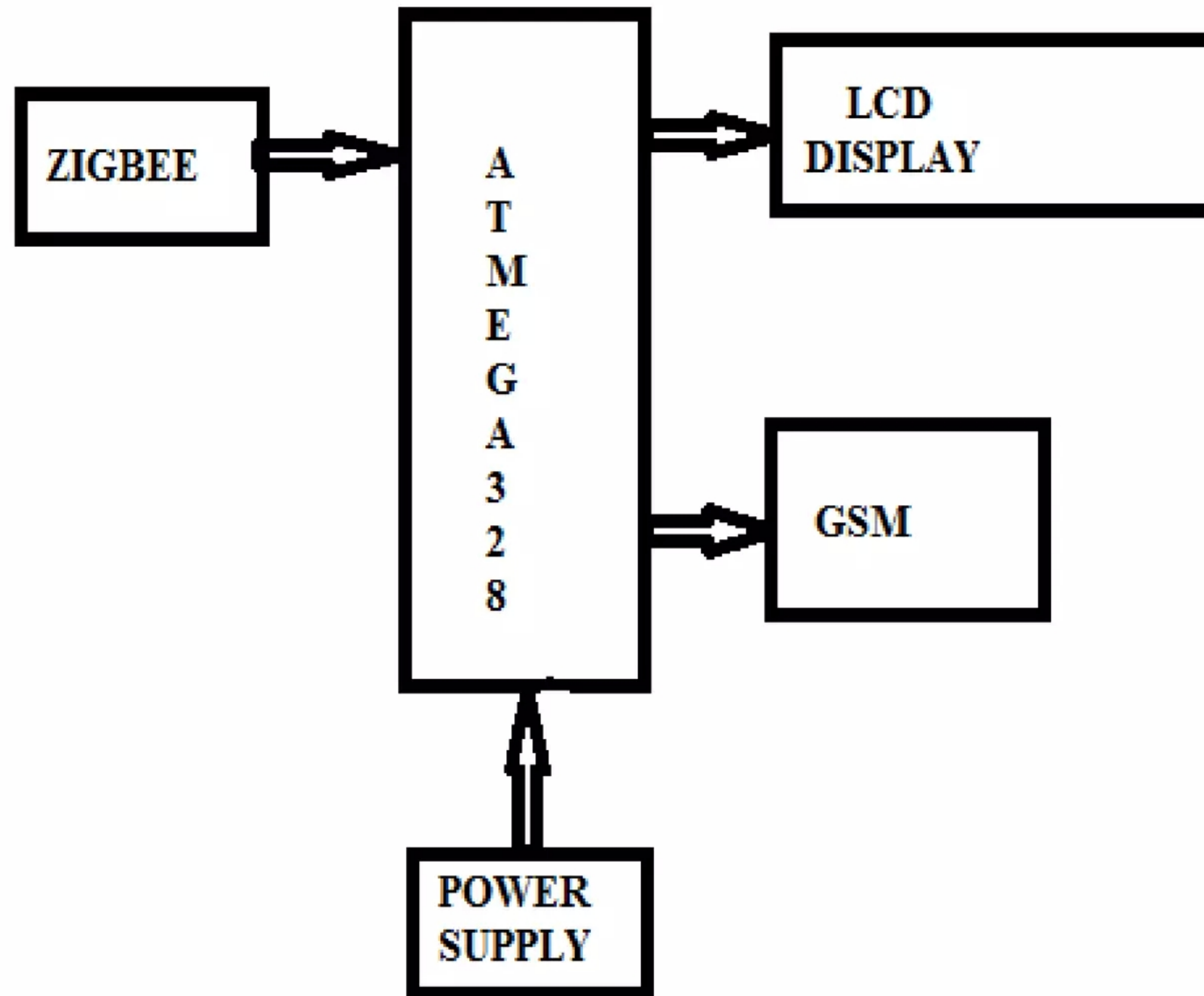

SENSORS

Three sensors used in the system which are mainly as follows:

1. Temperature
2. Soil moisture
3. Humidity

1. Temperature Sensor

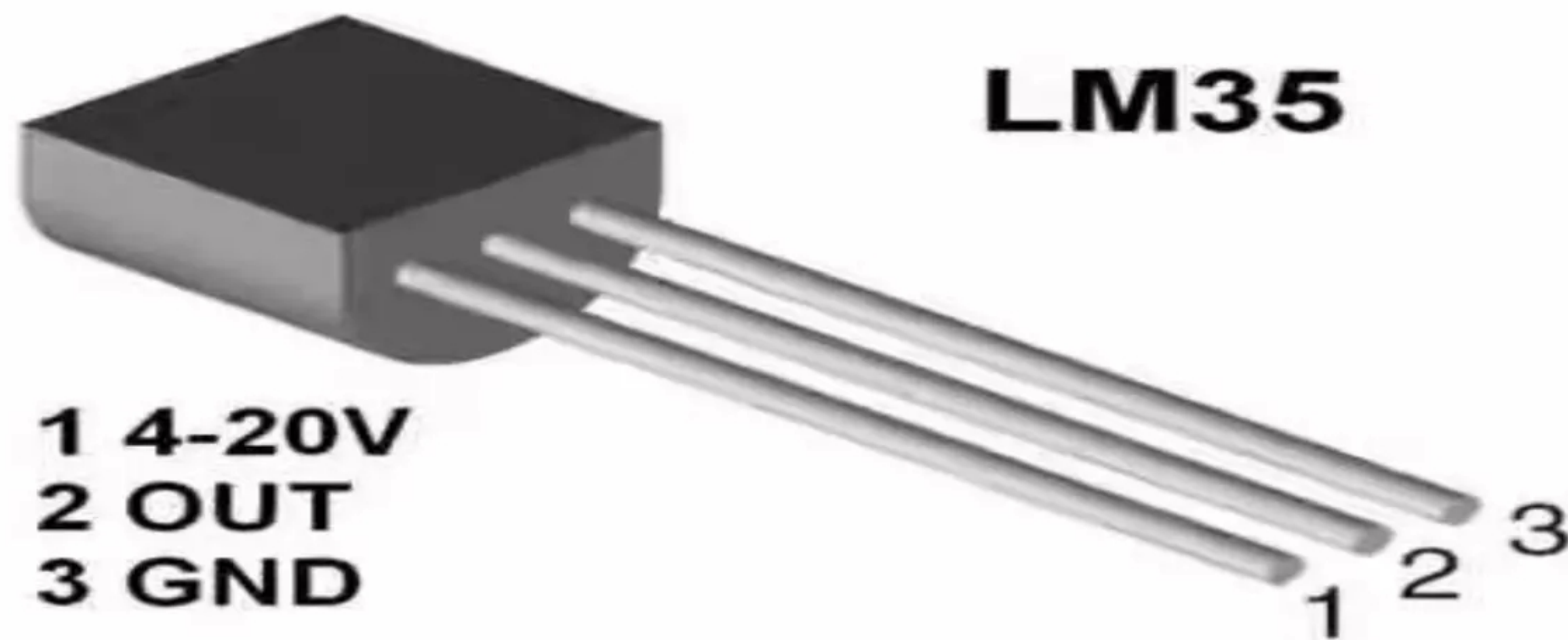

- **LM35**
- Output voltage is linearly proportional to the Celsius (Centigrade) temperature.
- Temperature range is **-55 to 150 degree C.**

2. Soil Moisture Sensors



- Common type is a **Frequency domain sensor**
- Neutron moisture gauge
- In this sensor we are using 2 probes to be dipped into the soil as per moisture we will get Analog Output variations from **0.60-12volts**. Input Voltage 12 VDC

3. Humidity Sensors

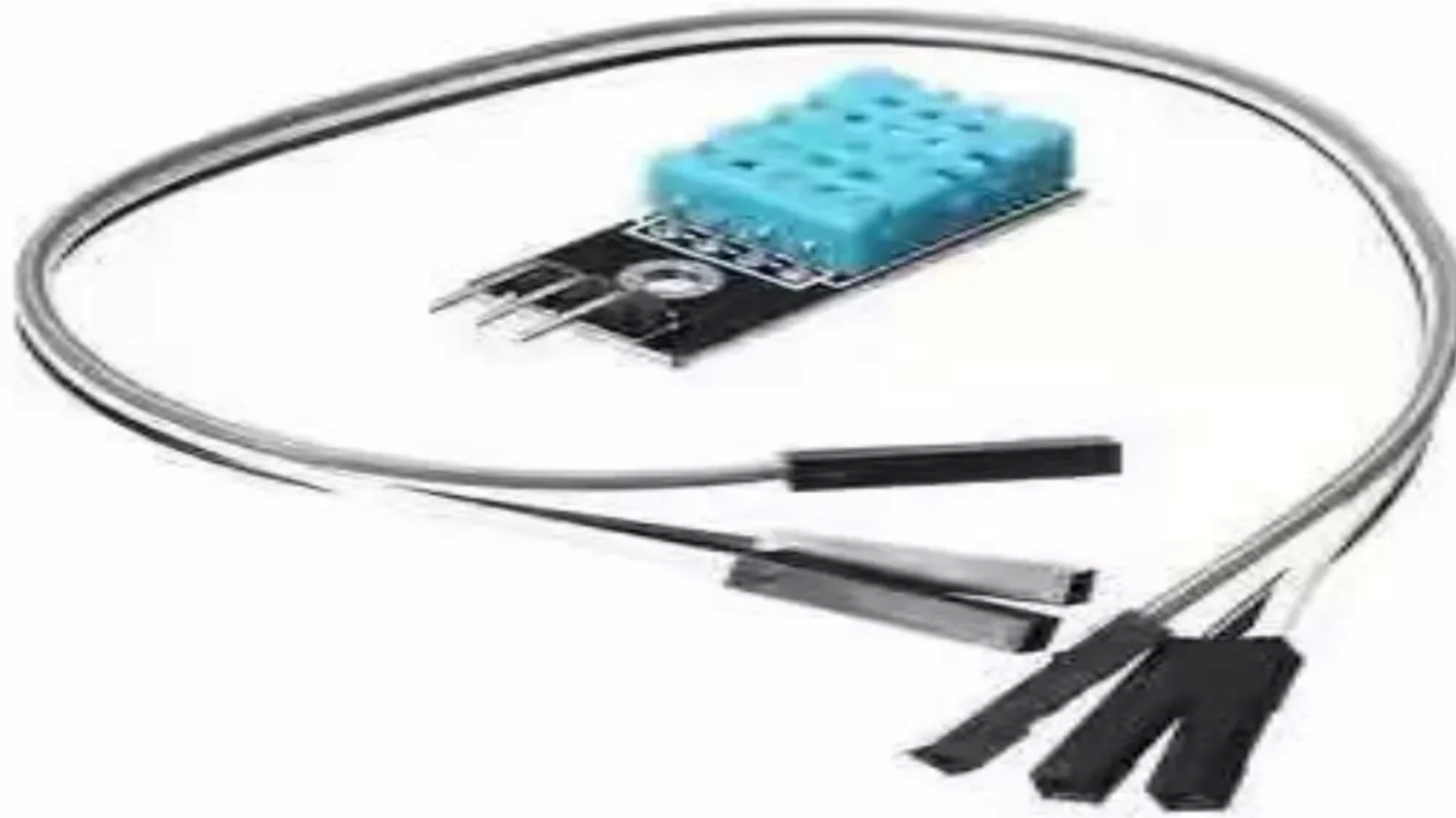

- It measures both air temperature and moisture.
- Relative humidity expressed as a **percentage**.
- **HS1100** is used for sensing humidity.
- The output in terms of frequency range **5khz to 10khz**.

MICROCONTROLLER



- **ATmega328P**
- ATmega328P gets a result of throughputs approaching **1 MIPS per MHz** which allows the system designer to find optimize power consumption versus processing speed

DATA TRANSMISSION

1. GSM MODULE



- The **SIM900** can be used embedded in many of the applications.
- The SIM900 has the capability of delivering GSM/GPRS **850/900/1800/1900MHz** performance for voice, Data, SMS and requires low power consumption.
- GSM900 has an small configuration of **24mm x 24mm x 3 mm**.
- Can be fit in nearly all the space requirement in **M2M** application, as there is slim and compact demand of design.

2. ZIGBEE MODULE



- Zigbee 802.15.4 RF modules are of XBee family, looking for excellent wireless performance.
- XBee Series 1 is depended on Zigbee 802.15.4 silicon from free scale.
- It is ideal for the topologies such as point-to-multipoint, point-to point.
- Automatic route discoveries are performed by the XBee Series 2 which can create a self-healing.
- network for the routers which are fully function and also for low-power end devices.

PROGRAMMABLE LOGIC

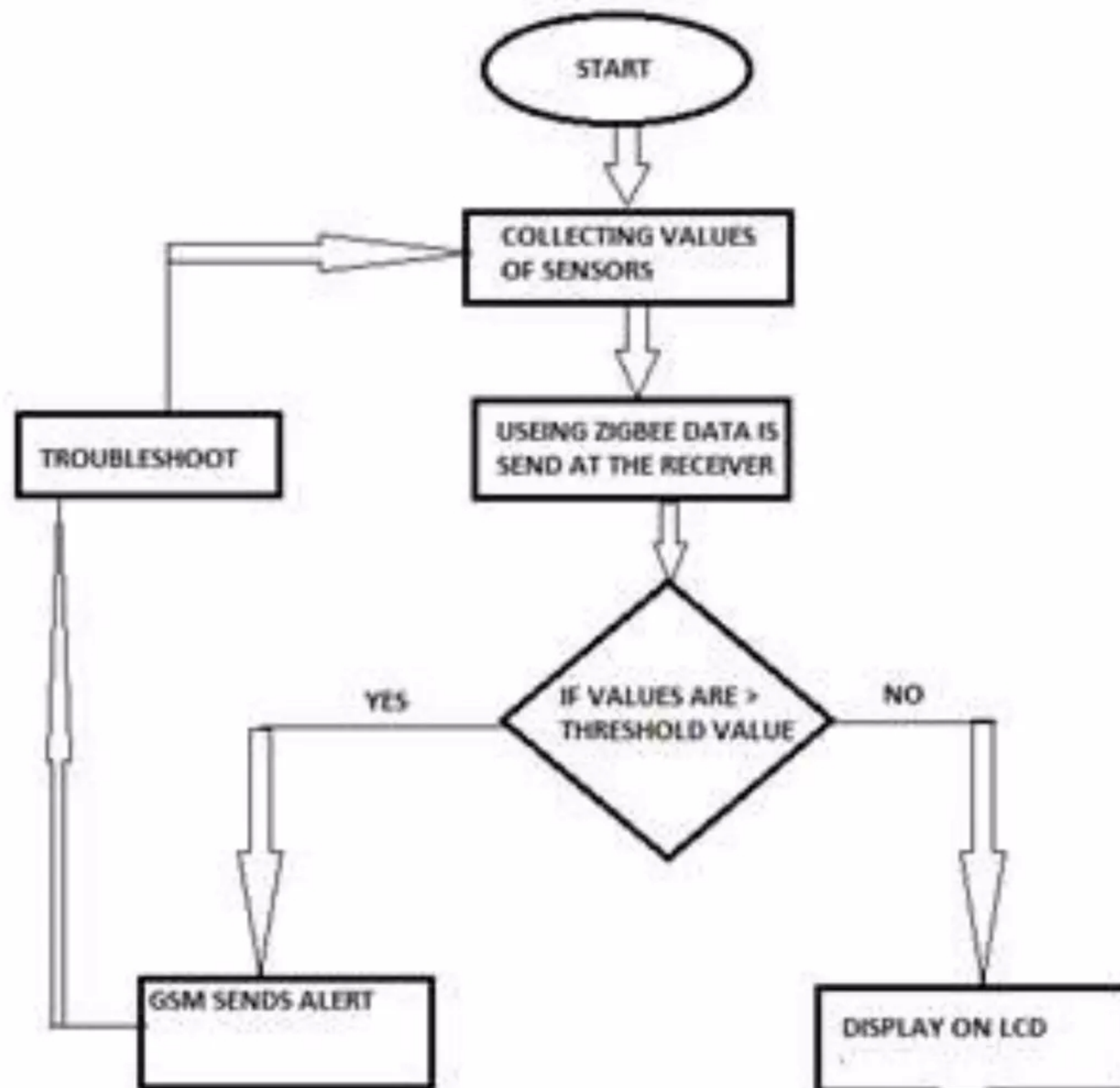

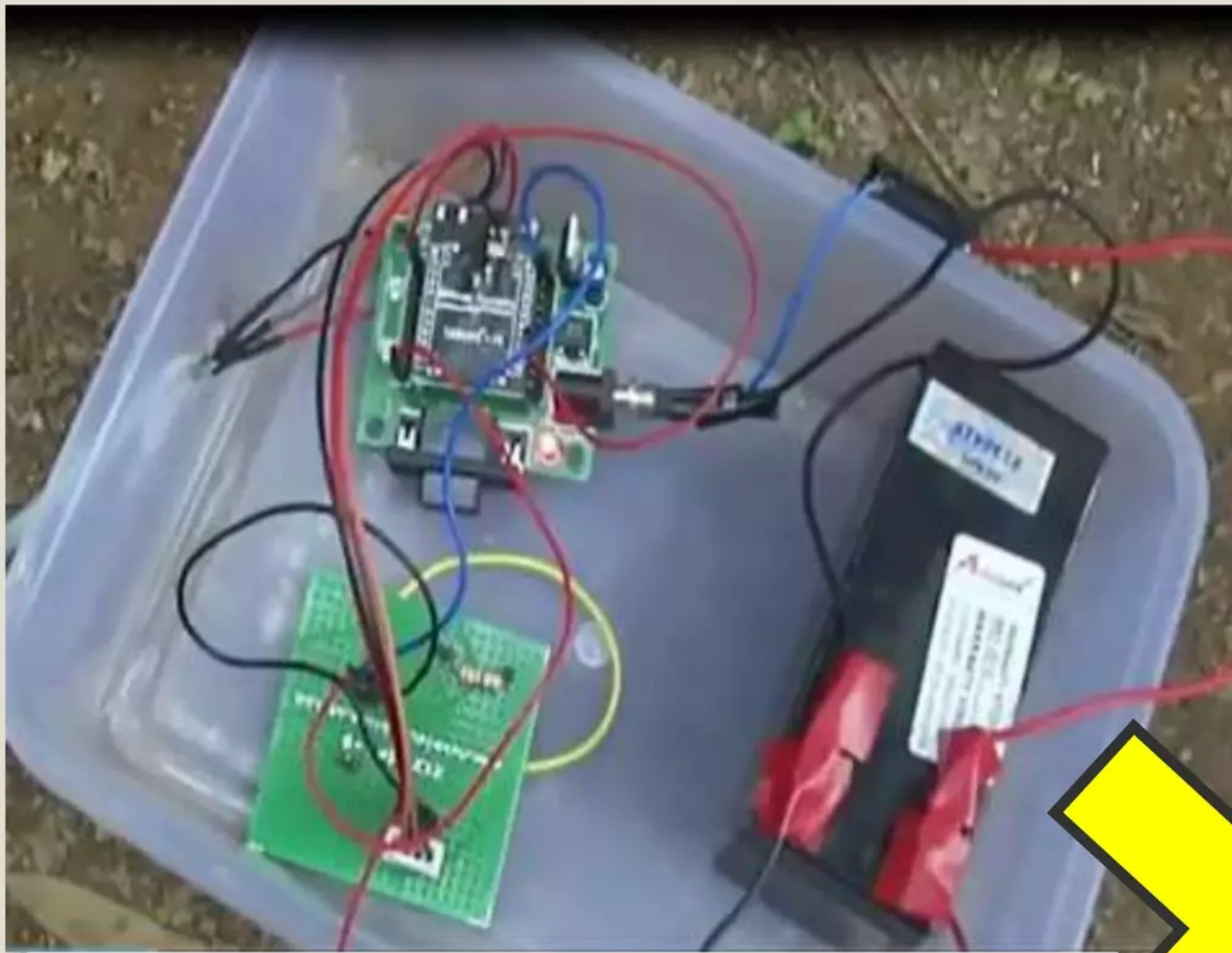

Transmitter section



Receiver section

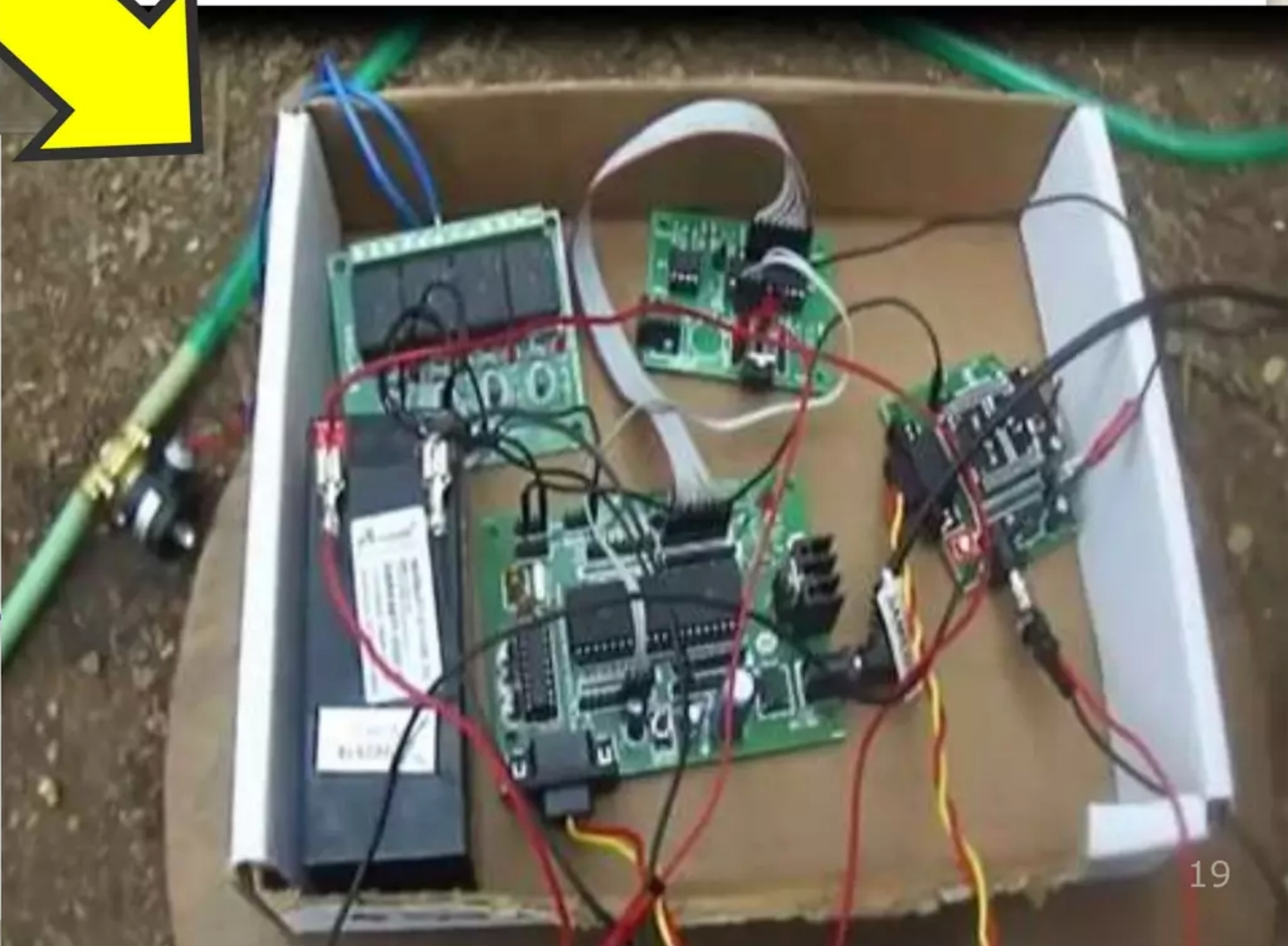

- System uses sensors to measure the relative parameter in order to give the water to crops.
- Outputs of the sensors measured are **analog** in nature the system makes use of **ADC** which is inbuilt in microcontroller
- These digital signals at microcontroller 328P then uses Zigbee module for communication to send data at the receiver and GSM module at the receiver side interfaced with microcontroller 328P for communication at a particular level.

- **Microcontroller** sends the measured values to wireless communication **zigbee module** and further uses **GSM module** to send message to the **farmer**.
- Microcontroller sends the measured values of different parameter and according that water is given to the crops.

ADVANTAGES

- Increase in productivity
- reduced water consumption
- Safe
- No manpower required
- Reduce soil erosion and nutrient leaching
- Require smaller water sources

CONCLUSIONS

- The smart irrigation system is **feasible and cost effective** for optimizing water resources for agricultural production.
- This irrigation system allows cultivation in places with **water scarcity** thereby improving sustainability.
- It proves that the use of water can be diminished.
- The use of **solar power** in this system is significantly important for organic crops.

REFERENCES

Tope G., Patel A. 2014. *International Journal Of Current Engineering And Scientific Research (IJCESR)*. Vol. 2.

www.ijert.org/ smart- irrigation-system-using-
wireless-sensor-network

The zigbee alliance website online available:

[http:// www.zigbee.org](http://www.zigbee.org)

Thank
you

