

Water Harvesting

- In general, water harvesting is the activity of direct collection of rainwater.
- The rainwater collected can be stored for direct use or can be recharged into the groundwater.
- Rain is the first form of water that we know in the hydrological cycle, hence is a primary source of water for us.
- Rivers, lakes and groundwater are all secondary sources of water.
- In present times, we depend entirely on such secondary sources of water.
- In the process, it is forgotten that rain is the ultimate source that feeds all these secondary sources and remain ignorant of its value.
- Water harvesting means to understand the value of rain, and to make optimum use of the rainwater at the place where it falls.

Benefit of Water Harvesting

- Improvement in the quality of ground water.
- Rise in the water levels in wells and bore wells that are drying up.
- Mitigation of the effects of drought and attainment of drought proofing.
- An ideal solution in areas having inadequate water resources.
- Reduction in the soil erosion as the surface runoff is reduced.
- Decrease in the choking of storm water drains and flooding of roads.
- Saving of energy to lift ground water.



Types of Water Harvesting

1. Rainwater Harvesting

Rainwater harvesting is defined as the method for inducing, collecting, storing and conserving local surface runoff for agriculture in arid and semi-arid regions.



Three Types of Water Harvesting are Covered by Rainwater Harvesting

- Water collected from **roof tops, courtyards** and similar compacted or treated surfaces is used for domestic purpose or garden crops.
- **Micro-catchment** water harvesting is a method of collecting surface runoff from a small catchment area and storing it in the root zone of an adjacent infiltration basin. The basin is planted with a tree, a bush or with annual crops.
- **Macro-catchment** water harvesting, also called harvesting from external catchments is the case where runoff from hill-slope catchments is conveyed to the cropping area located at foothill on flat terrain.

2. Flood Water Harvesting

Flood water harvesting can be defined as the collection and storage of creek flow for irrigation use. Flood water harvesting, also known as 'large catchment water harvesting' or 'Spate Irrigation', may be classified into following two forms:

- I. In case of 'flood water harvesting within stream bed', the water flow is dammed and as a result, inundates the valley bottom of the flood plain. The water is forced to infiltrate and the wetted area can be used for agriculture or pasture improvement.
- II. In case of 'flood water diversion', the wadi water is forced to leave its natural course and conveyed to nearby cropping fields.



3. Groundwater Harvesting

- Groundwater harvesting is a rather new term and employed to cover traditional as well as unconventional ways of ground water extraction.
- Qanat systems, underground dams and special types of wells are a few examples of the groundwater harvesting techniques.
- Groundwater dams like 'Subsurface Dams' and 'Sand Storage Dams' are other fine examples of groundwater harvesting.
- They obstruct the flow of ephemeral streams in a river bed; the water is stored in the sediment below ground surface and can be used for aquifer recharge.

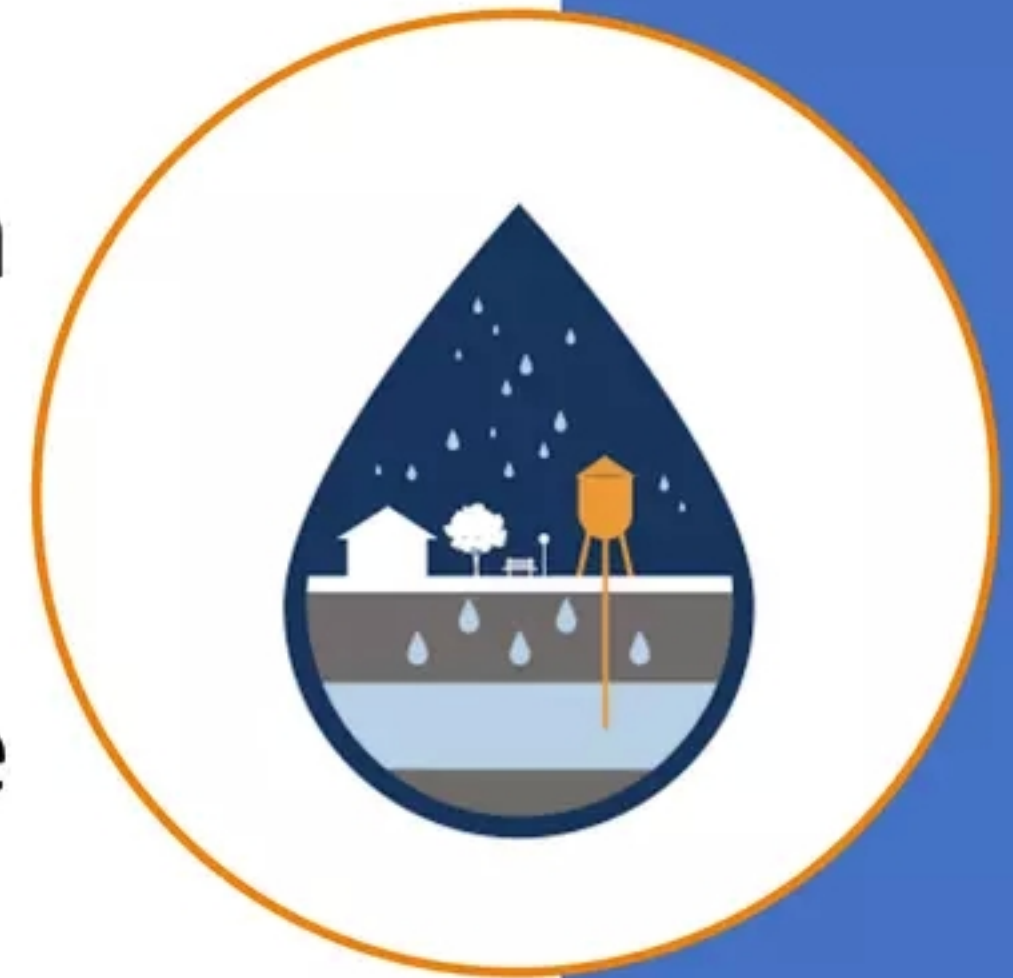

Water harvesting Technique

Runoff Harvesting

Short Term

Contour Bund

Semi-circular
Hoop

Trapezoidal
Bund

Graded Bunds

Rock
Catchment

Ground
Catchment

Long Term

Dugout Pond

Farm Ponds

Irrigation Dam

Silt detention Dam

High level Pond

Percolation Dam

Flood Water Harvesting

Permeable Rock Dam

Water Spreading Bunds

Flood Control Reservoir

Groundwater Harvesting

Qanat System

Runoff Harvesting

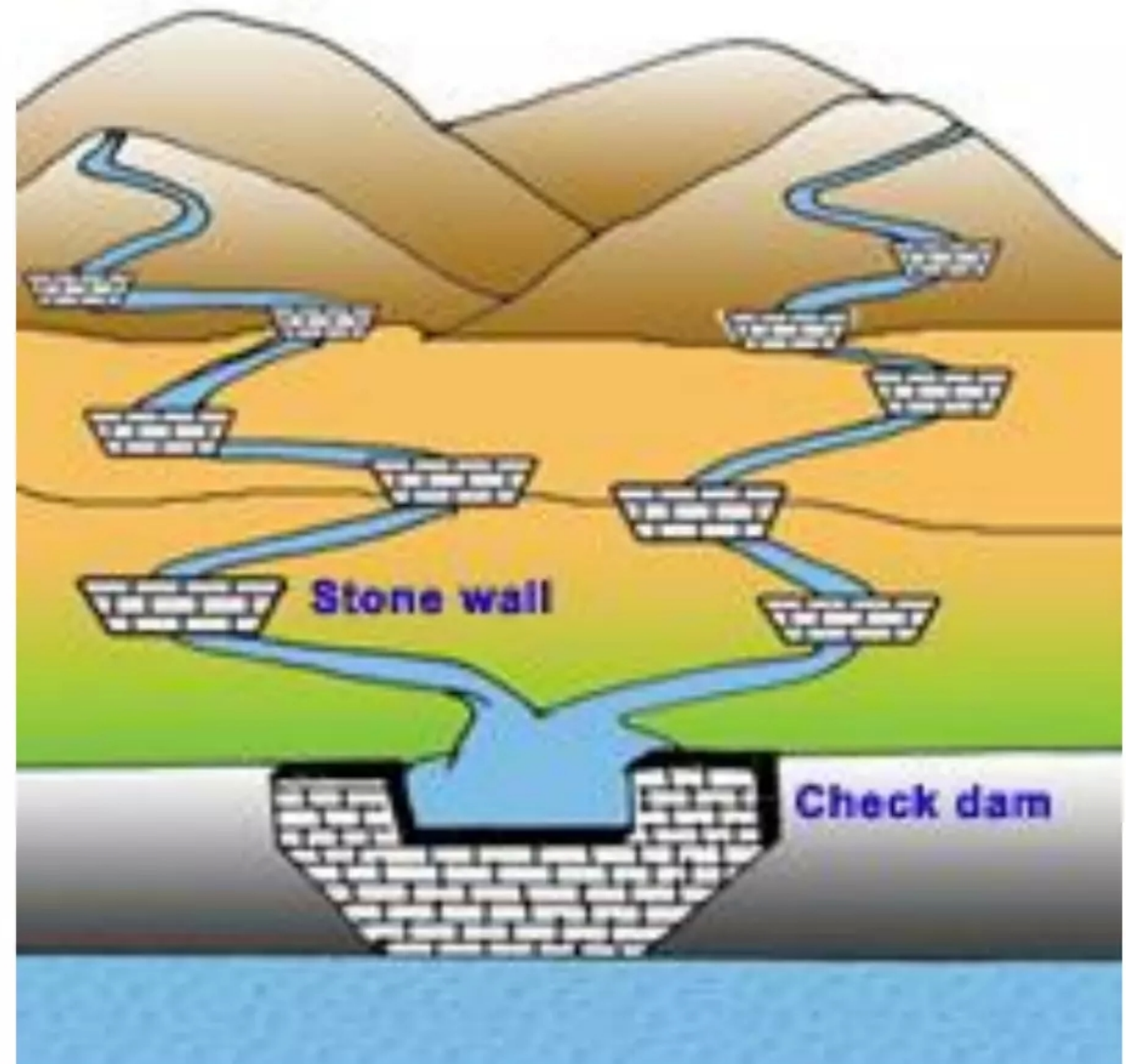

Runoff harvesting for short and long term is done by constructing structures as given below.

Short Term Runoff Harvesting Techniques

- 1. Contour Bunds**
- 2. Semi-circular Hoop**
- 3. Trapezoidal Bunds**
- 4. Graded Bunds**
- 5. Rock Catchment**
- 6. Ground Catchment**

Contour Bunds

- This method involves the construction of bunds on the contour of the catchment area.
- These bunds hold the flowing surface runoff in the area located between two adjacent bunds.
- The height of contour bund generally ranges from 0.30 to 1.0 m and length from 10 to a few 100 meters.

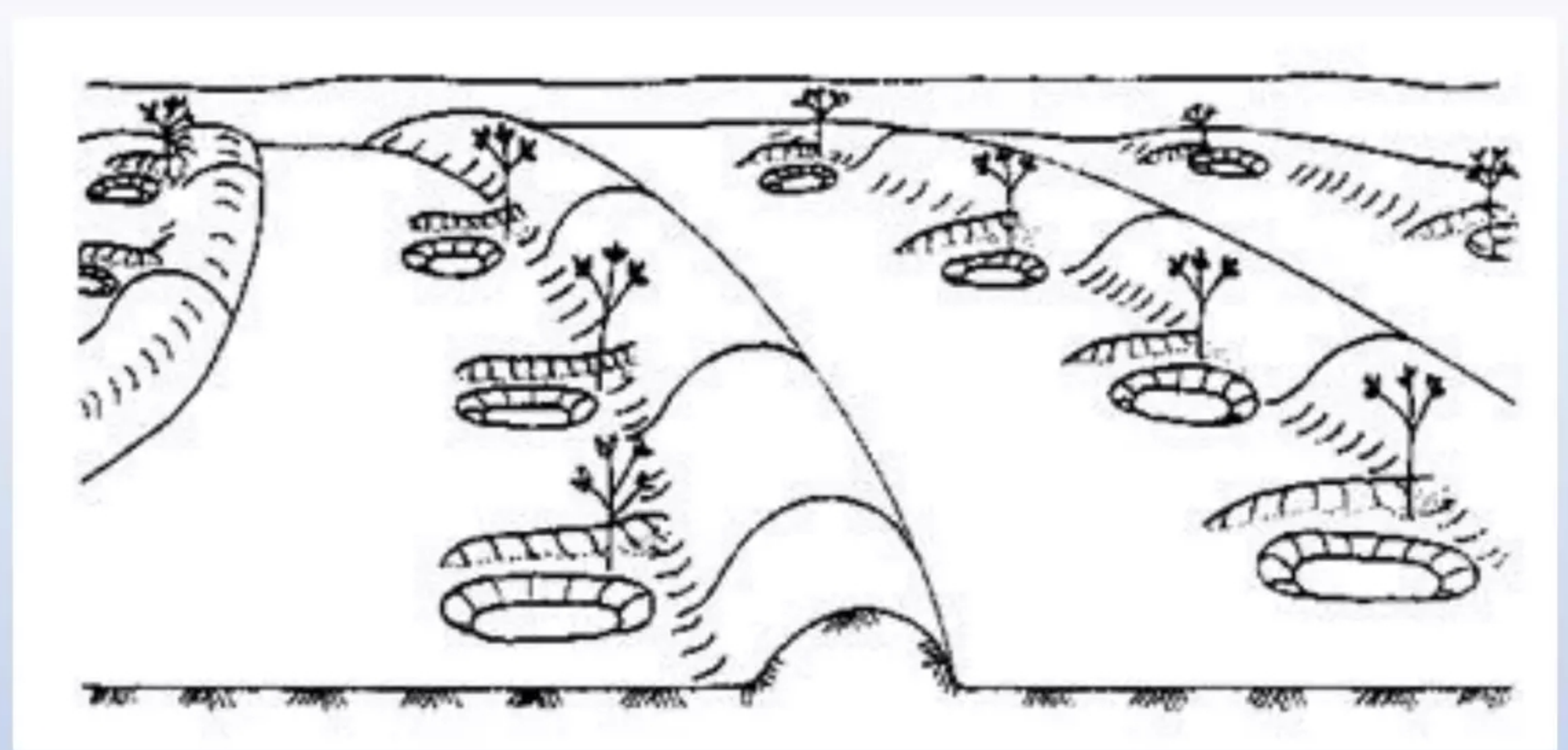

Semicircular Hoop

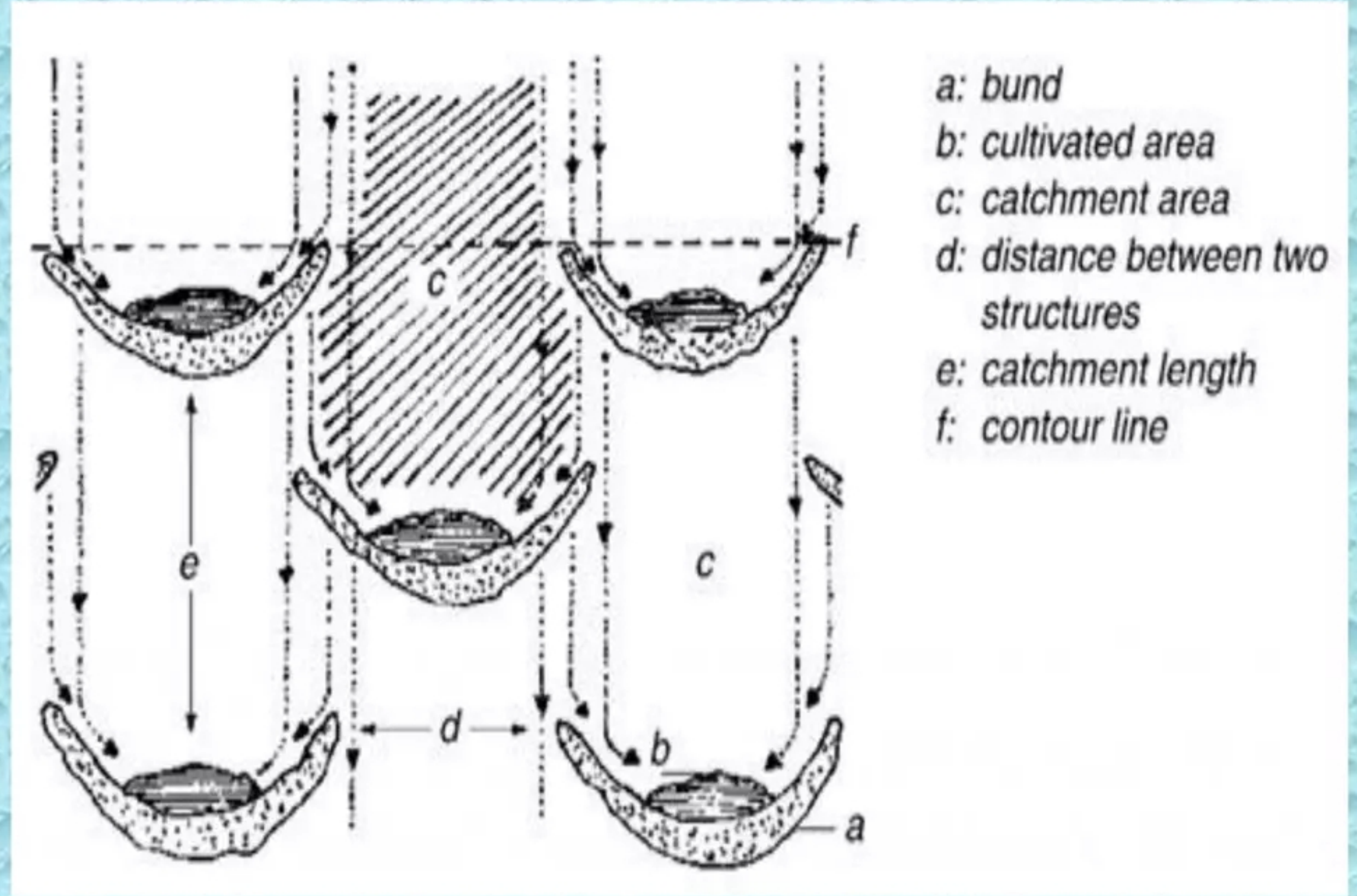

Semicircular Hoop

- This type of structure consists of an earthen impartment constructed in the shape of a semicircle.
- The tips of the semicircular hoop are furnished on the contour.
- The water contributed from the area is collected within the hoop to a maximum depth equal to the height of the embankment.
- Excess water is discharged from the point around the tips to the next lower hoop.
- The rows of semicircular hoops are arranged in a staggered form so that the over flowing water from the upper row can be easily interrupted by the lower row.
- The height of hoop is kept from 0.1 to 0.5 m and radius varies from 5 to 30 m.
- Such type of structure is mostly used for irrigation of grasses, fodder, shrubs, trees etc.

Trapezoidal Bunds

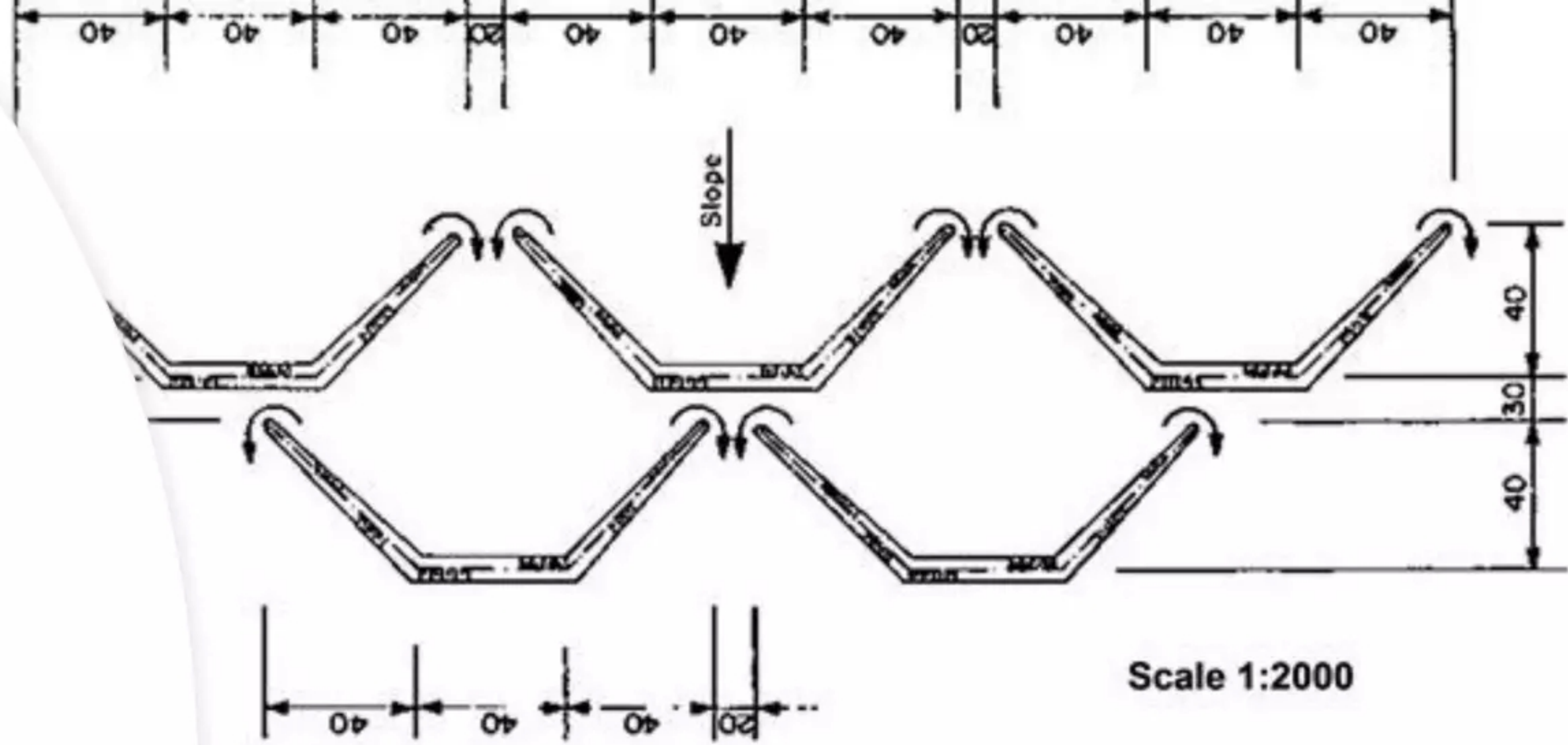

Trapezoidal Bunds

- Such bunds also consist of an earthen embankment, constructed in the shape of trapezoids.
- The tips of the bund wings are placed on the contour.
- The runoff water yielded from the watershed is collected into the covered area.
- The excess water overflows around the tips. In this system of water harvesting the rows of bunds are also arranged in staggered form to intercept the overflow of water from the adjacent upstream areas.
- The layout of the trapezoidal bunds is the same as the semicircular hoops, but they unusually cover a **larger area**.
- Trapezoidal bund technique is suitable for the areas where the rainfall intensity is too high and causes large surface flow to damage the contour bunds.
- This technique of water harvesting is widely used for irrigating crops, grasses, trees etc.

Graded Bunds



Graded Bunds

Graded bunds also referred as off contour bunds.

They consist of earthen or stone embankments and are constructed on a land with a slope range of 0.5 to 2%.

The design and construction of graded bunds are different from the contour bunds.

They are used as an option where rainfall intensity and soils are such that the runoff water discharged from the field can be easily intercepted.

The excess intercepted or harvested water is diverted to the next field through a channel ranges.

The height of the graded bund ranges from 0.3 to 0.6 m.



Rock Catchment



Rock Catchment

- The rock catchments are the exposed rock surfaces, used for collecting the runoff water in a part as depressed area.
- The water harvesting under this method can be explained as: when rainfall occurs on the exposed rock surface, runoff takes place very rapidly because there is very little loss.
- The runoff so formed is drained towards the lowest point called storage tank and the harvested water is stored there. The area of rock catchment may vary from a 100 m² to few 1000 m²; accordingly the dimensions of the storage tank should also be designed.
- The water collected in the tank can be used for domestic use or irrigation purposes.



Ground Catchment

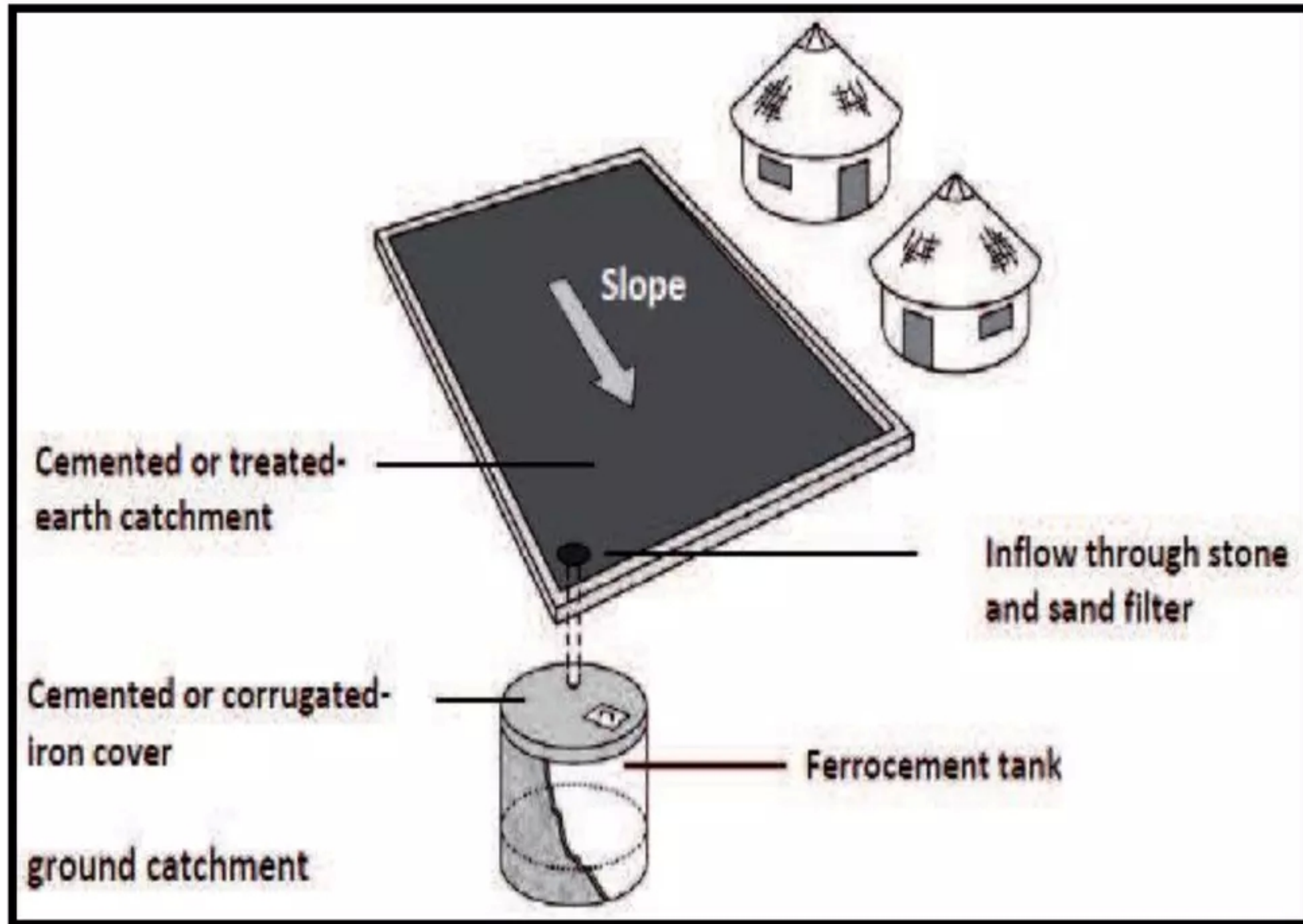

Ground Catchment

- In this method, a large area of ground is used as catchment for runoff yield.
- The runoff is diverted into a storage tank where it is stored.
- The ground is cleared from vegetation and compacted very well.
- The channels are as well compacted to reduce the seepage or percolation loss and sometimes they are also covered with gravel.
- Ground catchments are also called roaded catchments.
- This process is also called runoff inducement.
- Ground catchments have also been traditionally used since last 4000 years in the Negev (a desert in southern Israel) where annul crops and some drought tolerant species like pistachio dependent on such harvested water are grown.



Long Term Runoff Harvesting Techniques

10/2012 15:40

Long Term Runoff Harvesting Techniques

The long term runoff harvesting is done for building a large water storage for the purpose of irrigation, fish farming, electricity generation etc. It is done by constructing reservoirs and big ponds in the area.

The design criteria of these constructions are given below.

1. Watershed should contribute a sufficient amount of runoff.
2. There should be suitable collection site, where water can be safely stored.
3. Appropriate techniques should be used for minimizing various types of water losses such as seepage and evaporation during storage and its subsequent use in the watershed.
4. There should also be some suitable methods for efficient utilization of the harvested water for maximizing crop yield per unit volume of available water.

Long Term Runoff Harvesting Structures

1. Dugout Ponds
2. Farm Pond
3. High Level Pond
4. Irrigation Dam
5. Silt Detension Dam
6. Percolation Dam



Dugout Pond

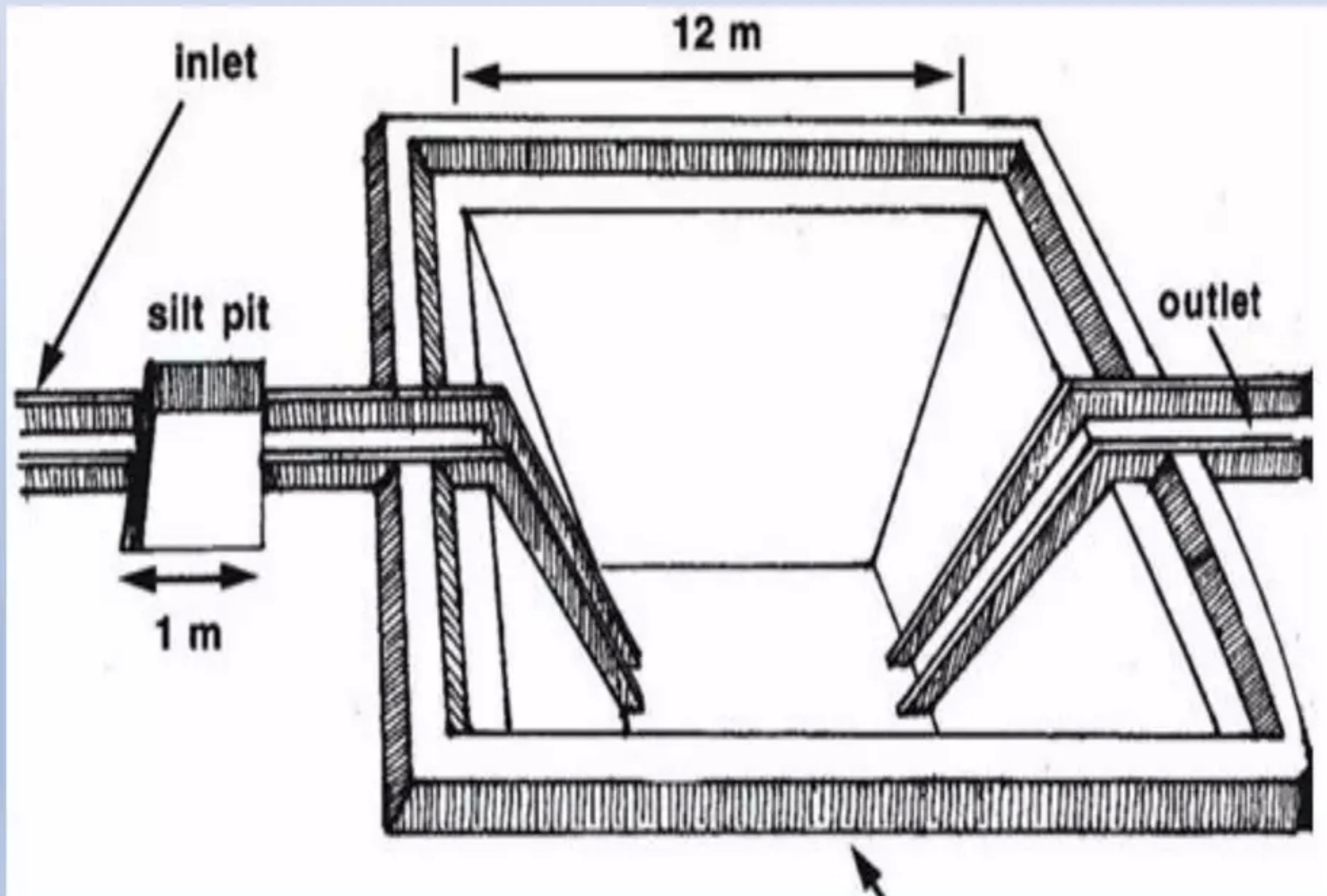

Dugout Ponds

- The dugout ponds are constructed by excavating the soil from the ground surface.
- These ponds may be fed by ground water or surface runoff or by both.
- Construction of these ponds is limited to those areas which have land slope less than 4% and where water table lies within 1.5-2 meters depth from the ground surface.
- Dugout ponds involve more construction cost, therefore these are generally recommended when embankment type ponds are not economically feasible.
- Dugout ponds can also be recommended where maximum utilization of the harvested runoff water is possible for increasing the production of some important crops.
- This type of ponds require brick lining with cement plastering to ensure maximum storage by reducing the seepage loss.

Irrigation Dam

- The irrigation dams are mainly meant to store the surface water for irrigating the crops.
- The capacity is decided based on the amount of input water available and output water desired.
- These dams have the provisions of gated pipe spillway for taking out the water from the reservoir.
- Spillway is located at the bottom of the dam leaving some minimum dead storage below it.



Silt Detention Dam

Silt Detention Dam

- The basic purpose of silt detention dam is to detain the silt load coming along with the runoff water from the catchment area and simultaneously to harvest water.
- The silt laden water is stored in the depressed part of the catchment where the silt deposition takes place and comparatively silt free water is diverted for use.
- Such dams are located at the lower reaches of the catchment where water enters the valley and finally released into the streams.
- In this type of dam, provision of outlet is made for taking out the water for irrigation purposes.
- For better result a series of such dams can be constructed along the slope of the catchment.

An aerial photograph showing a large, dark pond in the lower center, surrounded by dense green trees. To the right, a residential neighborhood with houses and streets is visible. The upper portion of the image shows a large, open green field with some trees and a path. A dark, semi-transparent overlay covers the left side of the image.

High Level Pond

High Level Pond

- Such dams are located at the head of the valley to form the shape of a water tank or pond.
- The stored water in the pond is used to irrigate the area lying downstream. Usually, for better result a series of ponds can be constructed in such a way that the command area of the tank located upstream forms the catchment area for the downstream tank.
- Thus all but the uppermost tanks are facilitated with the collection of runoff and excess irrigation water from the adjacent higher catchment area.



Farm Pond

- Farm ponds are constructed for multi-purpose objectives, such as for irrigation, live-stock, water supply to the cattle feed, fish production etc.
- The pond should have adequate capacity to meet all the requirements.
- The location of farm pond should be such that all requirements are easily and conveniently met.



Water Harvesting Pond

- The farm ponds can be considered as water harvesting ponds.
- They may be dugout or embankment type.
- Their capacity depends upon the size of catchment area.
- Runoff yield from the catchment is diverted into these ponds, where it is properly stored.
- Measures against seepage and evaporation losses from these ponds should also be.



Percolation Dam

- These dams are generally constructed at the valley head, without the provision of checking the percolation loss.
- Thus, a large portion of the runoff is stored in the soil.
- The growing crops on downstream side of the dam, receive the percolated water for their growth.



Flood Water Harvesting

1. Permeable Rock Dams
2. Water Spreading Bunds
3. Flood Control Reservoir



Flood Water Harvesting

- To harvest flood water, wide valleys are reshaped and formed into a series of broad level terraces and the flood water is allowed to enter into them.
- The flood water is spread on these terraces where some amount of it is absorbed by the soil which is used later on by the crops grown in the area.
- Therefore, it is often referred to as "Water Spreading" and sometimes "Spate Irrigation".



The main characteristics of water spreading are:

- Turbulent channel flow is harvested either by diversion or by spreading within the channel bed/valley floor.
- Runoff is stored in soil profile.
- It has usually a long catchment (may be several km)
- The ratio between catchment to cultivated area lies above 10:1.
- It has provision for overflow of excess water.

Permeable Rock Dams

- These are long low rock dams across valleys slowing and spreading floodwater as well as healing gullies.
- These are suitable for a situation where gently sloping valleys are likely to transform into gullies and better water spreading is required.

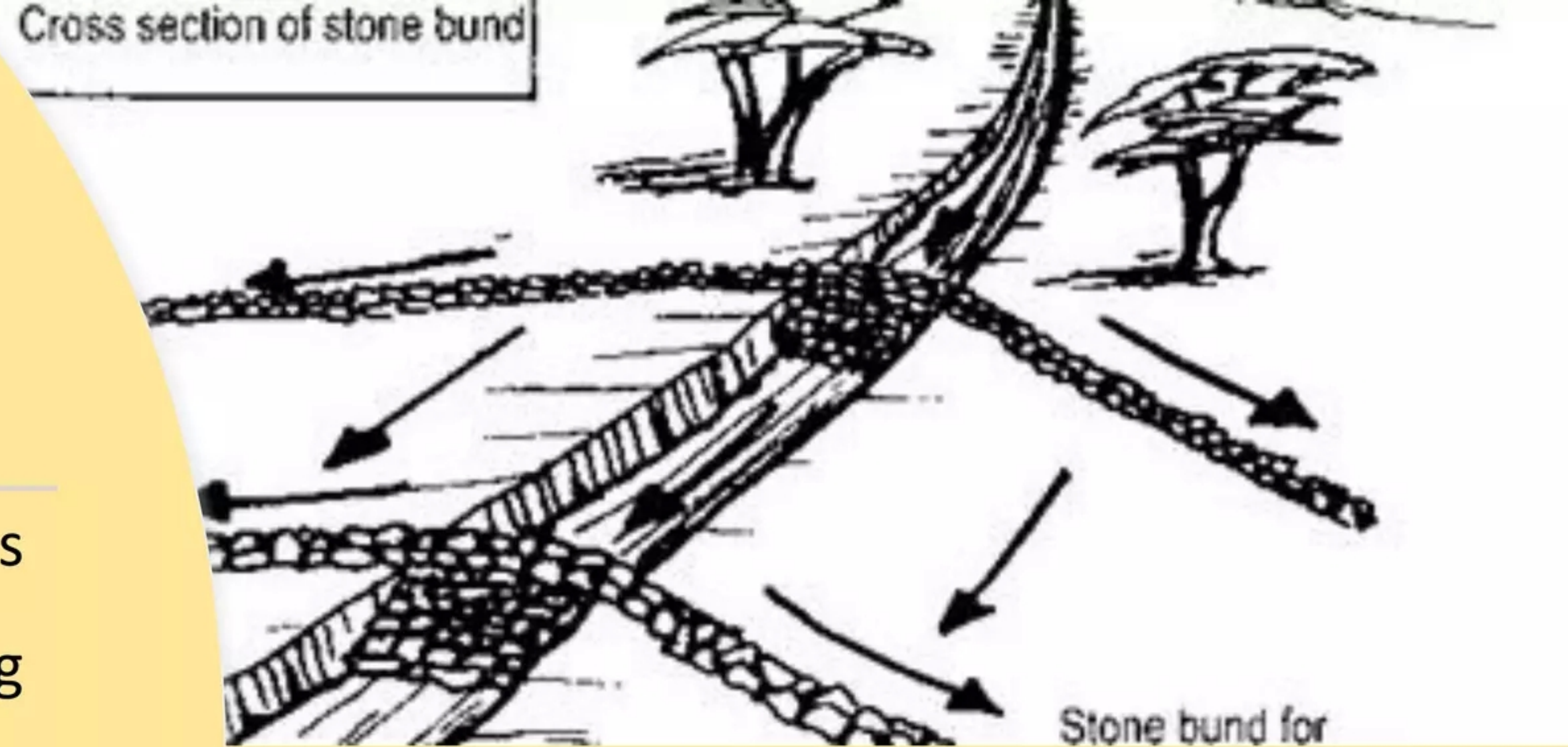

Water Spreading Bunds

- In this method, runoff water is diverted to the area covered by graded bund by constructing diversion structures such as diversion drains.
- They lead to the basin through channels, where crops are irrigated by flooding.
- Earthen bunds are set at a gradient, with a "dogleg" shape and helps in spreading diverted floodwater.
- These are constructed in arid areas where water is diverted from watercourse onto crop or fodder block.

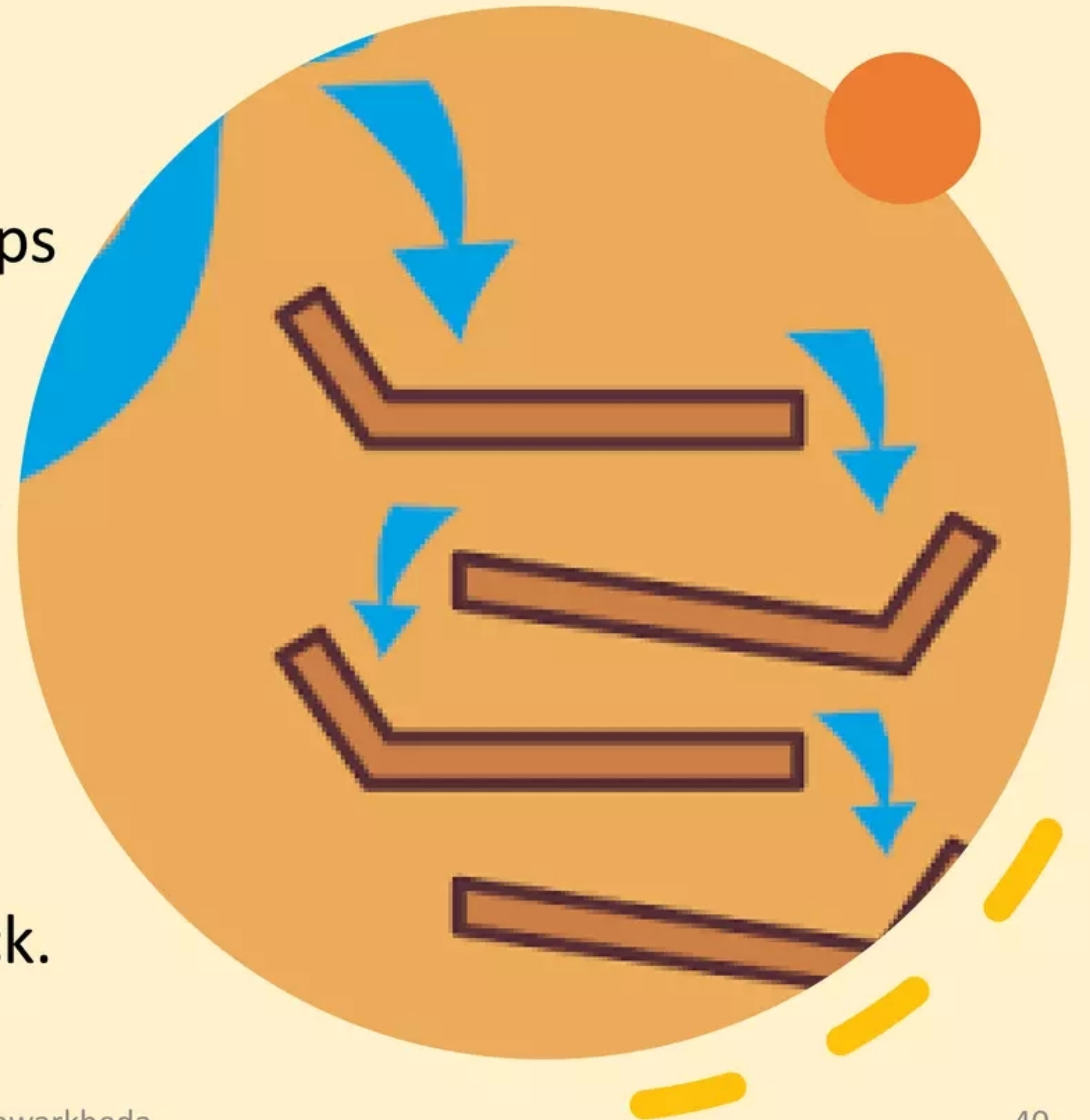

Flood Control Reservoir

- The reservoirs constructed at suitable sites for controlling the flood are known as flood control reservoirs.
- They are well equipped with self-operating mechanical outlets for letting out the harvested water into the stream or canal below the reservoir as per requirement.



General Allocation of Storage in a Reservoir

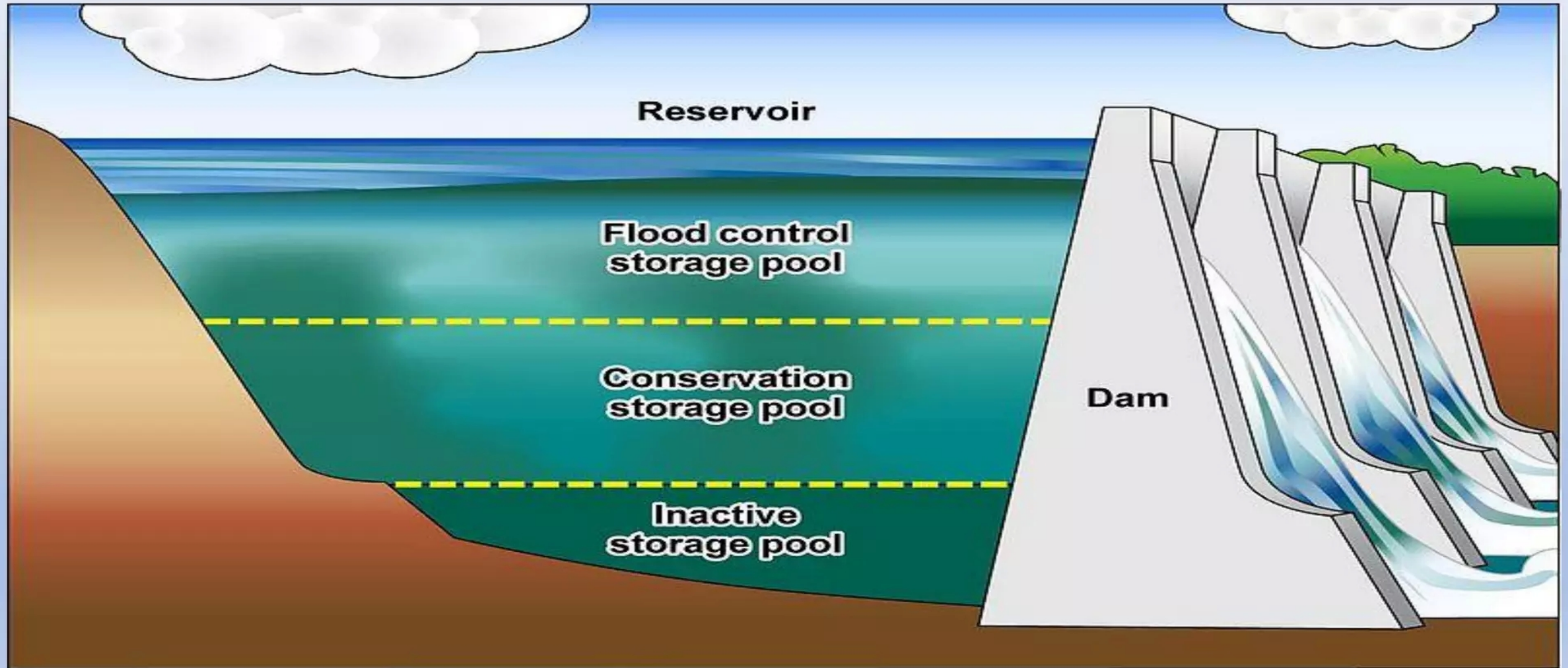

Groundwater Harvesting

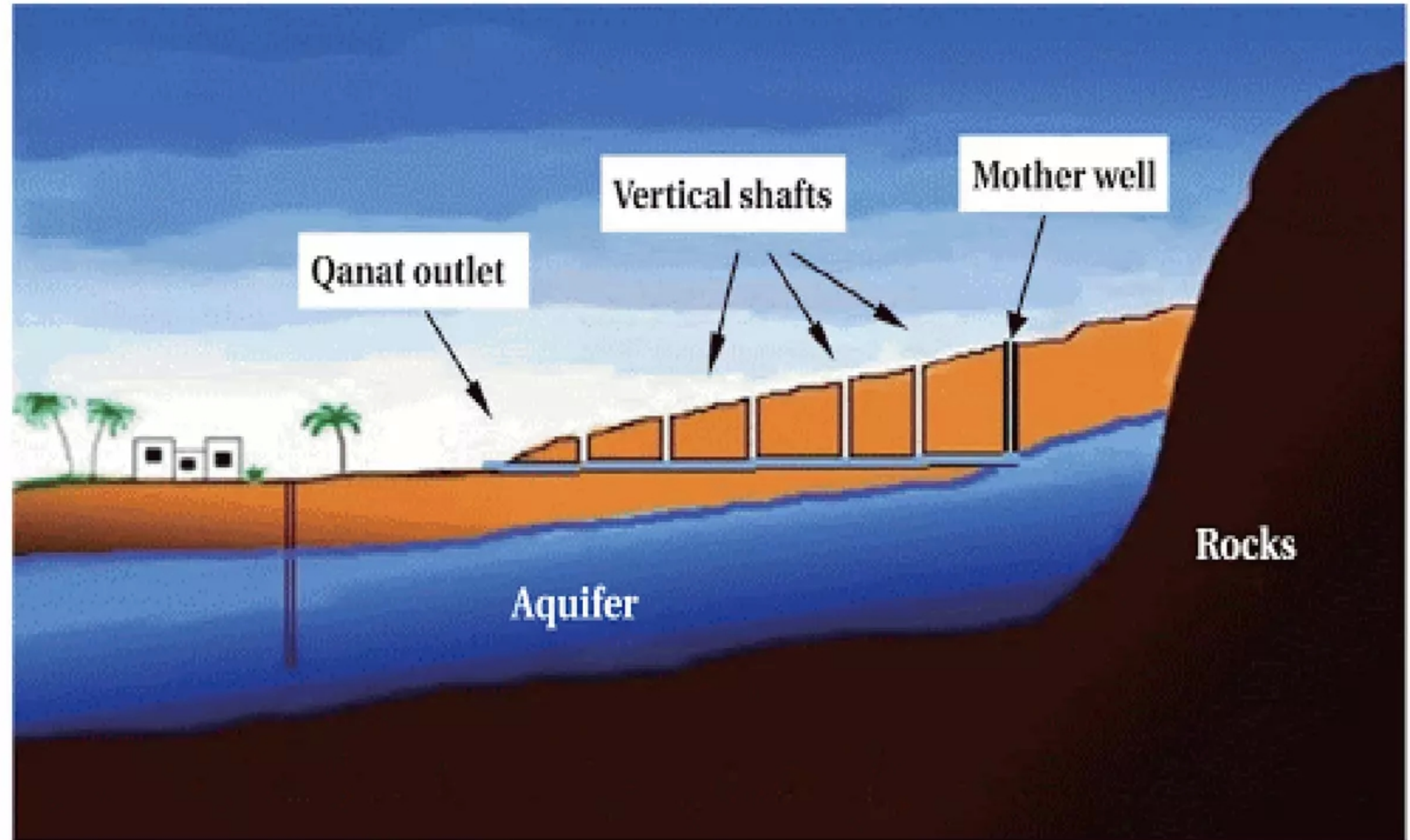

Qanat System

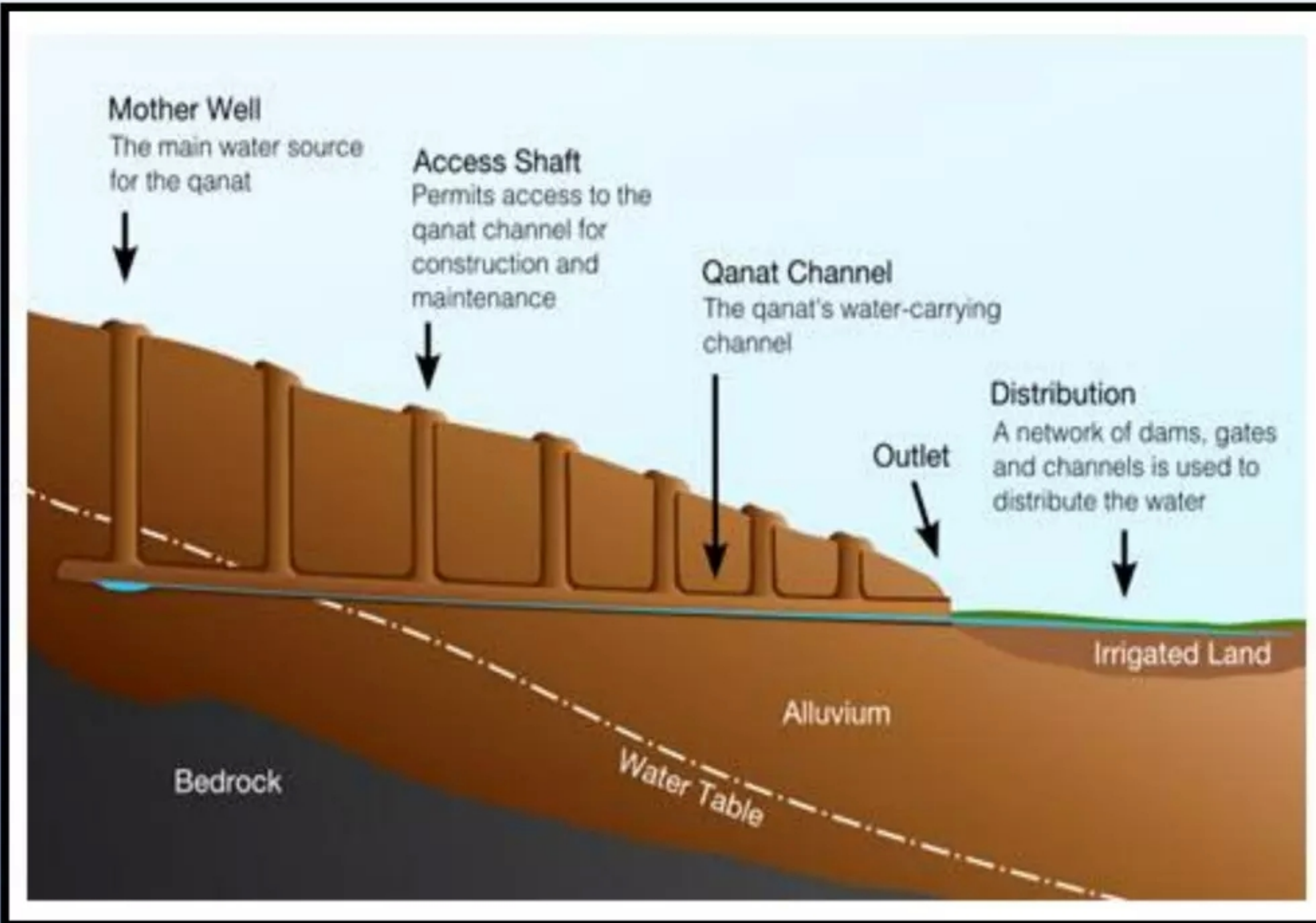

Cross Section Showing Qanats



Ariel view of Qanats.

Qanat System

- A qanat consists of a long tunnel or conduit leading from a well dug at a reliable source of groundwater (the mother well).
- Often, the mother well is dug at the base of a hill or in the foothills of a mountain range.
- The tunnel leading from the mother well slopes gradually downward to communities in the valley below.
- Access shafts are dug intermittently along the horizontal conduit to allow for construction and maintenance of the qanat.

- The Qanat system was used widely across Persia and the Middle East for many reasons.
- First, the system requires no energy, relies on the force of gravity alone.
- Second, the system can carry water across long distances through subterranean chambers avoiding leakage, evaporation, or pollution.
- And lastly, the discharge is fixed by nature, producing only the amount of water that is distributed naturally from a spring or mountain, ensuring that the water table is not depleted.
- More importantly, it allows access to a reliable and plentiful source of water to those living in otherwise marginal landscapes.

Roof Top Rain Water Harvesting

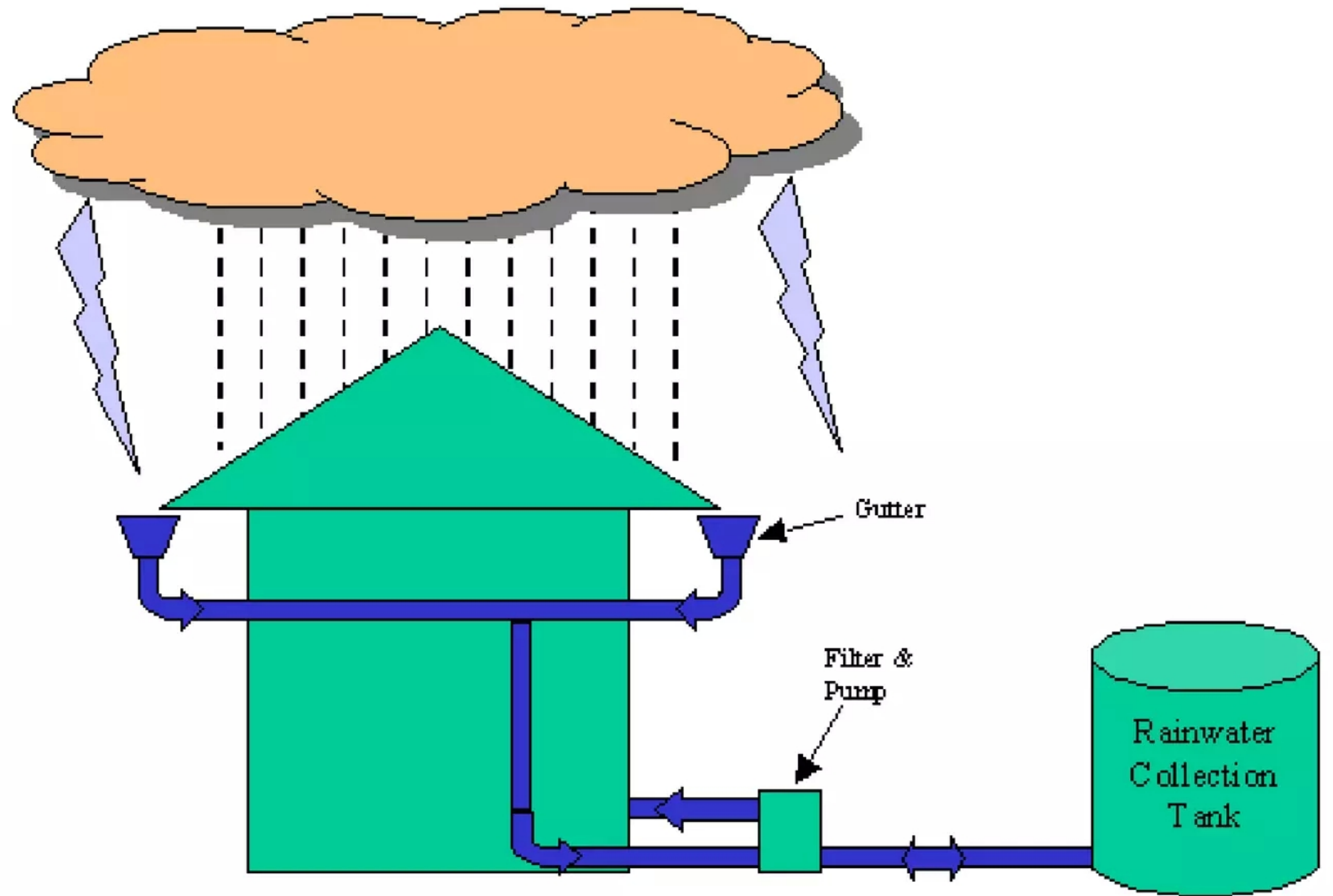

Rainwater Collection Overview

Roof Top Rain Water Harvesting

- Rooftop Rain Water Harvesting is the technique through which rain water is captured from the roof catchments and stored in reservoirs.
- Harvested rain water can be stored in sub-surface ground water reservoir by adopting artificial recharge techniques to meet the household needs through storage in tanks.
- The Main Objective of rooftop rain water harvesting is to make water available for future use.
- Capturing and storing rain water for use is particularly important in dryland, hilly, urban and coastal areas.
- In alluvial areas energy saving for 1m. rise in ground water level is around 0.40 kilo watt per hour.

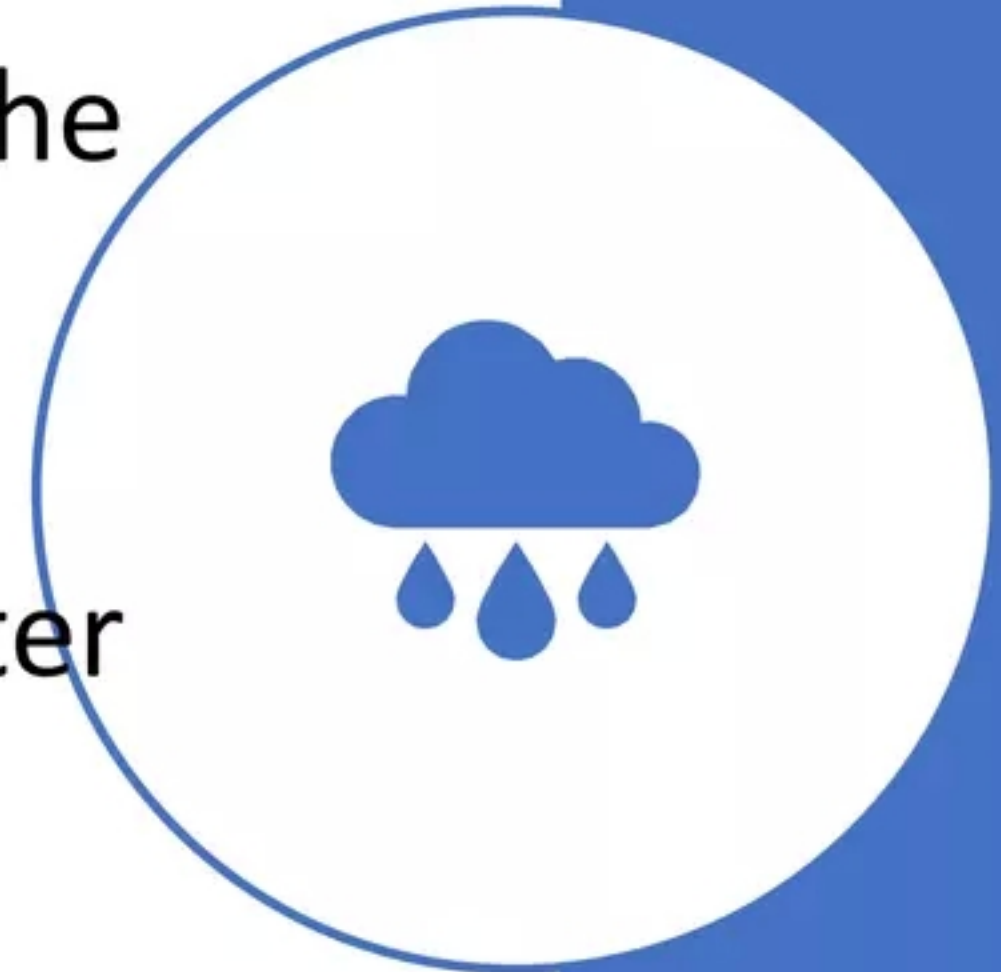

Need for Rooftop Rain-Water Harvesting

1. To meet the ever-increasing demand for water.
2. To reduce the runoff which chokes storm drains.
3. To avoid flooding of roads.
4. To reduce ground water pollution.
5. To improve the quality of ground water.
6. To reduce the soil erosion.
7. To augment the ground water storage and control decline of water levels.
8. To supplement domestic water requirement during summer, drought etc.



**RAIN-
WATER**

**USE
FOR
LIFE**



Advantages of Rain Water Harvesting

1. Provides self-sufficiency to your water supply.
2. Reduces the cost for pumping of ground water.
3. Provides high quality water, soft and low in minerals.
4. Improves the quality of ground water through dilution when recharged to ground water.
5. Reduces soil erosion in urban areas.
6. Rooftop rainwater harvesting is less expensive.
7. Rainwater harvesting systems are simple which can be adopted by individuals.

8. Rooftop rain water harvesting systems are easy to construct, operate and maintain.
9. In hilly terrains, rain water harvesting is preferred.
10. In saline or coastal areas, rain water provides good quality water and when recharged to ground water, it reduces salinity and also helps in maintaining balance between the fresh-saline water interface.
11. In Islands, due to limited extent of fresh water aquifers, rain water harvesting is the most preferred source of water for domestic use.
12. In desert, where rain fall is low, rain water harvesting has been providing relief to people.



Safety Consideration

Storage in Ground Water Reservoir

1. For rooftop rain water harvesting through existing tubewells and handpumps, filter or desilting pit should be provided so that the wells are not silted.
2. Such tubewells if pumped intermittently, increase the efficiency of recharge.
3. If the ground water reservoir is recharged through, shaft, dug well etc., inverted filter may be provided.



Storage in Tanks

1. storage tank should not be located close to a source of contamination, such as a septic tank etc.
2. A storage tank must be located on a lower level than the roof to ensure that it fills completely.
3. A rainwater system must include installation of an overflow pipe which empties into a non-flooding area. Excess water may also be used for recharging the aquifer through dug well or abandoned handpump or tubewell etc.
4. A speed breaker plate must be provided below inlet pipe in the filter so as not to disturb the filtering material.
5. Storage tanks should be accessible for cleaning.
6. The inlet into the Storage tank should be screened in such way that these can be cleaned regularly.
7. Water may be disinfected regularly before using for drinking purpose by chlorination or boiling etc.

Components of Roof Top Rain Water Harvesting system

1. Catchment
2. Transportation (Gutter, Pipe, Fittings)
3. First Flush System
4. Filter
5. Storage Facility
6. Recharge Facility

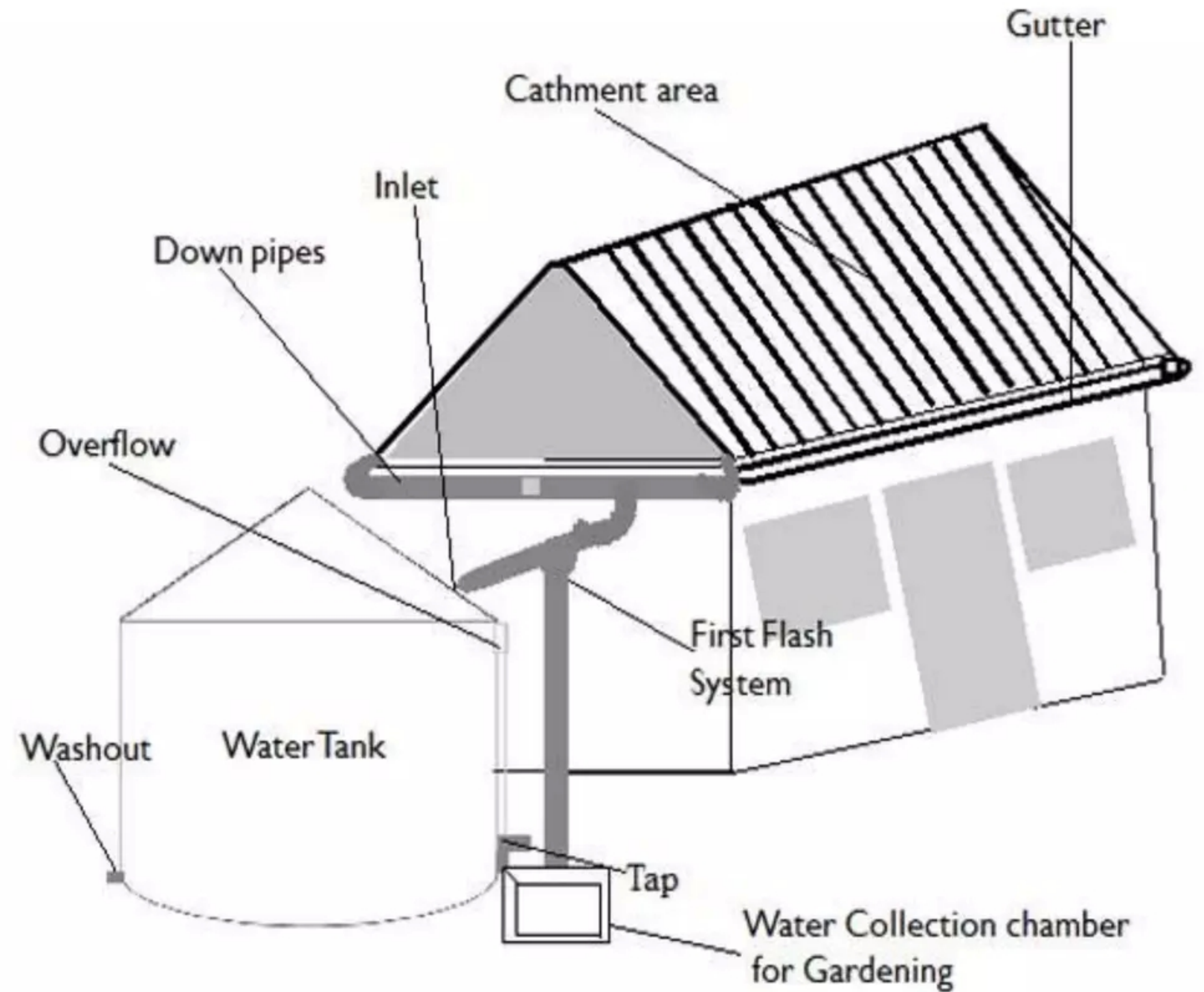

1. Catchment

- The surface that receives rainfall directly is the catchment of rainwater harvesting system.
- It may be a terrace, courtyard, or paved or unpaved open ground.
- The terrace may be a flat RCC/stone roof or sloping roof.
- Therefore the catchment is the area, which actually contributes rainwater to the harvesting system.

2. Transportation

- Rainwater from the rooftop should be carried through down take water pipes or drains to the storage/harvesting system.
- Water pipes should be UV resistant (ISI HDPE/PVC pipes) of the required capacity.
- Water from sloping roofs could be caught through gutters and down take the pipe.
- At terraces, the mouth of each drain should have wire mesh to restrict floating material.

3. First Flush

- The first flush is a device used to flush off the water received in the first shower.
- The first shower of rains needs to be flushed-off to avoid contaminating storable/rechargeable water by the probable contaminants of the atmosphere and the catchment roof.
- It will also help in cleaning of silt and other material deposited on the roof during dry seasons.
- Provisions of first rain separators should be made at the outlet of each drainpipe.

4. Filters

- Filters are used for the treatment of water to effectively remove turbidity, color, and microorganisms.
- After the first flushing of rainfall, water should pass through filters.
- A gravel, sand, and 'netlon' mesh filter is designed and placed on top of the storage tank.
- This filter is very important in keeping the rainwater in the storage tank clean.
- It removes silt, dust, leaves, and other organic matter from entering the storage tank.

5. Storage facility

- There are various options available for the construction of these tanks with respect to the shape, size, material of construction and the position of tank and they are: -
Shape : Cylindrical, square and rectangular.

6. Recharge Structures

- Rainwater Harvested can also be used for charging the groundwater aquifers through suitable structures like dugwells, borewells, recharge trenches and recharge pits.
- Various recharge structures are possible – some which promote the percolation of water through soil strata at shallower depth (e.g., recharge trenches, permeable pavements) whereas others conduct water to greater depths from where it joins the groundwater (e.g. recharge wells).

Precautions

1. The roof or terraces used for harvesting should be clean.
2. Do not store chemicals, rusting iron, manure or detergent on the roof.
3. Avoid using terraces for toilet by you and your pets.
4. Provide gratings at mouth of each drainpipe on terraces to trap debris and floating materials.
5. Prevent storage system from contamination.
6. Provision of first rain separator should be made to flush first rain.
7. Do not use polluted water to recharge ground water.
8. Before recharging arrangements of filtering should be provided



Thanks for listening.....

Questions ?