

SOIL AND WATER CONSERVATION ENGINEERING

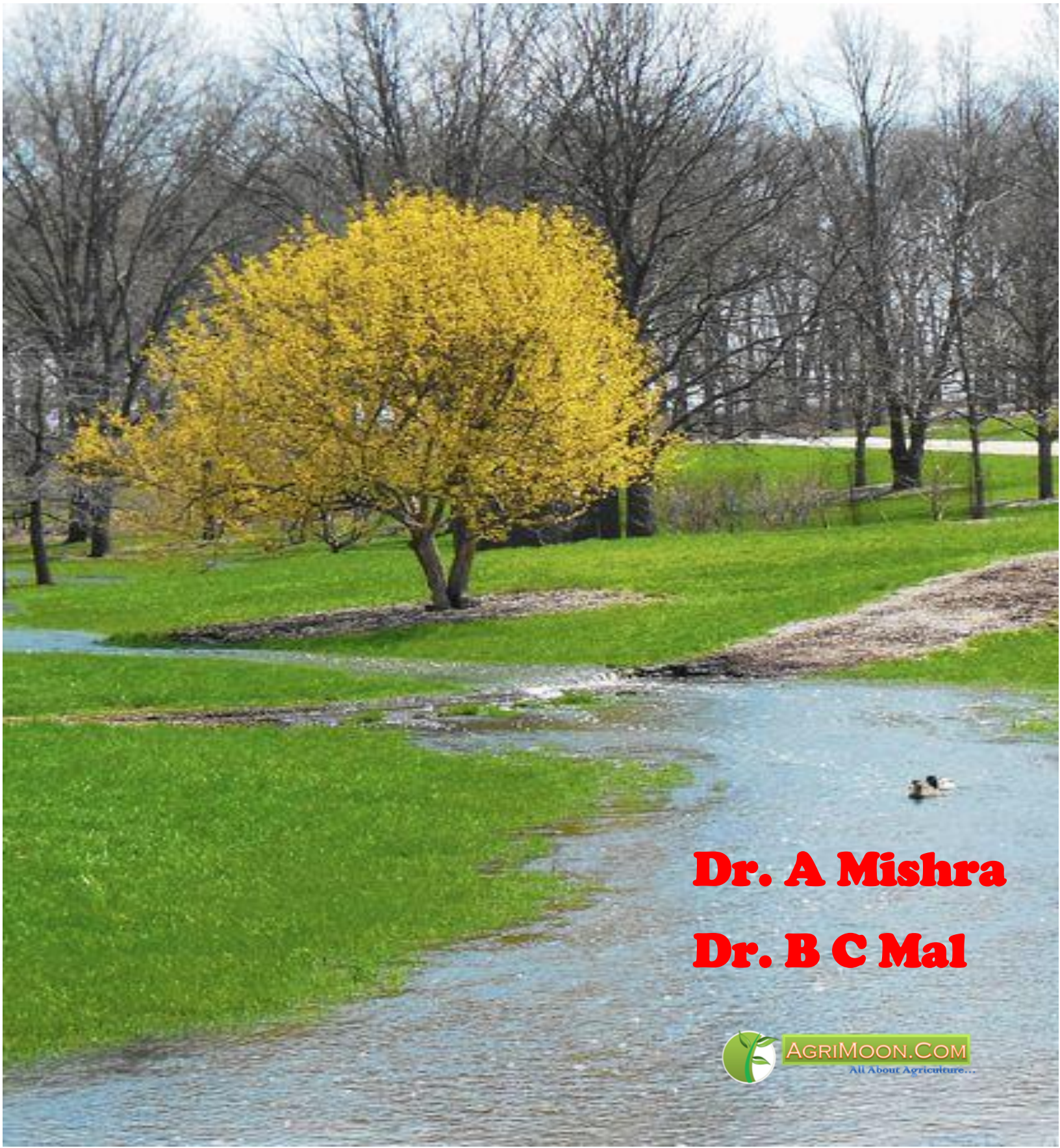

Dr. A Mishra

Dr. B C Mal



AGRIMOON.COM
All About Agriculture...

Soil and Water Conservation Engineering

-: Course Content Developed By :-

Dr. A Mishra

Assistant Professor

Dept. of Agricultural and Food Engg., IIT Kharagpur

-:Content Reviewed by :-

Dr. B C Mal

**Professor, Agricultural and Food Engg. Dept. IIT
Kharagpur**

**(Vice-Chancellor) Swami Vivekanand Technical
University, Bilai, (Chhattisgarh)**



AGRIMOON.COM

All About Agriculture...

Index

Lesson Name	Page No
Module 1: Introduction and Concept of Soil Erosion	
Lesson 1: Introduction	5-13
Lesson 2: Principles of Soil Erosion	14-19
Module 2: Water Erosion and Control	
Lesson 3: Erosion Due to Water	20-25
Lesson 4: Agronomical Measures for Water Erosion Control	26-30
Lesson 5: Terraces for Water Erosion Control	31-38
Lesson 6: Bunding Methods for Water Erosion Control	39-45
Lesson 7: Gully Erosion	46-57
Lesson 8: Drop Spillway	58-66
Lesson 9: Drop Inlet Spillway	67-72
Lesson 10: Chute Spillway	73-77
Lesson 11: Earthen Dam	78-83
Lesson 12: Stream Bank Erosion	84-90
Lesson 13: River Training and Stream Bank Protection	91-99
Module 3: Wind Erosion, Estimation and Control	
Lesson 14: Wind Erosion and Its Estimation	100-104
Lesson 15: Wind Erosion Control Measures	105-110
Module 4: Soil Loss-Sediment Yield Estimation	
Lesson16: Soil Loss/Sediment Yield Estimation	111-119
Lesson17: Erosivity and Erodibility	120-128
Lesson 18: Estimation of USLE Parameters	129-136
Module 5: Sedimentation	
Lesson 19: Sedimentation of Water Resources	137-141
Lesson 20: Sediment Transport and Measurements	142-148
Lesson 21: In-stream Sediment Measurements	149-154
Lesson 22: Reservoir Sedimentation	155-161
Module 6: Topographic Survey and Contour Maps	
Lesson 23: Land Survey and Contour Maps	162-171
Lesson 24: Leveling and Grading of Land	172-180
Module 7: Land Use Capability Classification	
Lesson 25: Land Use and Capability Classification	181-187
Lesson 26 Land Evaluation and Improvement	188-192
Module 8: Grassed Waterways	
Lesson 27: Grassed Waterways	193-200

Module 9: Water Harvesting	
Lesson 28: Water Harvesting	201-209
Module 10: Water Quality and Pollution	
Lesson 29: Water Pollution	210-216
Lesson 30 Water Quality	217-228
Module 11: Watershed Modeling	
Lesson 31: Modeling of Watershed Processes	229-232
Lesson 32: Case Study-Watershed Modelling for Soil and Water Conservation and Water Quality	233-246

Module 1: Introduction and Concept of Soil Erosion

Lesson 1 Introduction

1.1 Why Soil and Water Conservation?

Soil and water are two important natural resources and the basic needs for agricultural production. During the last century it has been observed that the pressure of increasing population has led to degradation of these natural resources. In other words increase in agricultural production to feed the increasing population is only possible if there sufficient fertile land and water are available for farming. In India, out of 328 million hectares of geographical area, 68 million hectares are critically degraded while 107 million hectares are severely eroded. That's why soil and water should be given first priority from the conservation point of view and appropriate methods should be used to ensure their sustainability and future availability. Status of global land degradation is shown in Fig. 1.1.

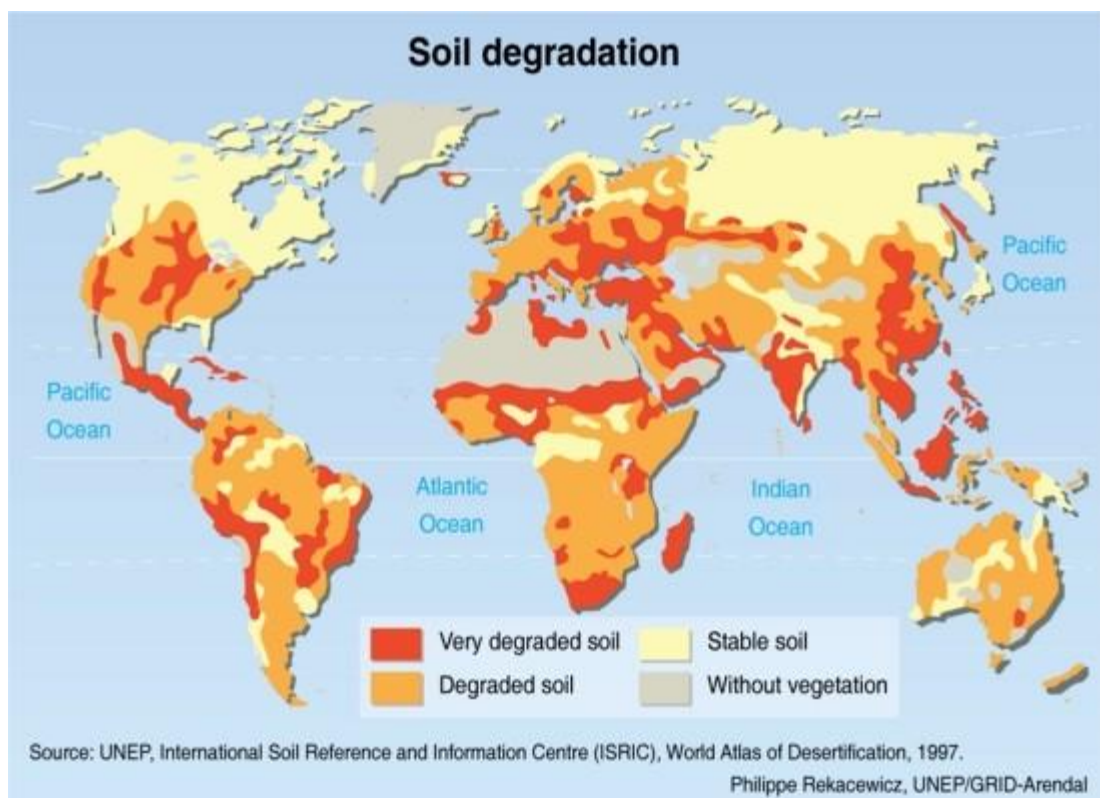

Fig. 1.1. Global soil degradation map.

(Source: UNEP, International Soil Reference and Information Centre (ISRIC), World Atlas of Desertification, 1997)

Water conservation is the use and management of water for the good of all users. Water is abundant throughout the earth, yet only three percent of all water is fresh water, and less than seven-tenths of freshwater is usable. Much of the usable water is utilized for irrigation. Detailed analysis will show that in about fifteen years, about two-thirds of the world's population will be living in some sort of water shortage. Water is used in nearly every aspect of life. There are multiple domestic, industrial and agricultural uses. Water conservation is

rapidly becoming a hot topic, yet many people do not realize the importance of soil conservation.

Soil conservation is defined as the control of soil erosion in order to maintain agricultural productivity. Soil erosion is often the effect of many natural causes, such as water and wind. There are also human factors which increase the rate of soil erosion such as construction, cultivation and other activities. Some may argue that since it is a natural process, soil erosion is not harmful. The truth is that with the removal of the top layer of soil, the organic matter and nutrients are also removed.

Conservation is not just the responsibility of soil and plant scientists, hydrologists, wildlife managers, landowners, and the forest or mine owner alone.

All citizens should be made aware about the importance of natural resources as our lives depend on that and everyone should be involved in the process of caring of these resources properly and using them intelligently.

1.1.1 What is Soil Erosion?

The uppermost weathered and disintegrated layer of the earth's crust is referred to as soil. The soil layer is composed of mineral and organic matter and is capable of sustaining plant life. The soil depth is less in some places and more at other places and may vary from practically nil to several metres. The soil layer is continuously exposed to the actions of atmosphere. Wind and water in motion are two main agencies which act on the soil layer and dislodge the soil particles and transport them. The loosening of the soil from its place and its transportation from one place to another is known as soil erosion.

The word erosion has been derived from the Latin word 'erodere' which means eating away or to excavate. The word erosion was first used in geology for describing the term hollow created by water. Erosion actually is a two phase process involving the detachment of individual soil particle from soil mass, transporting it from one place to another (by the action of any one of the agents of erosion, viz; water, wind, ice or gravity) and its deposition. When sufficient energy is not available to transport a particle, a third phase known as deposition occurs. In general, finer soil particles get eroded more easily than coarse particles (silt is more easily eroded than sand). Hence soil erosion is defined as a process of detachment, transportation and deposition of soil particles (sediment). It is evident that sediment is the end product of soil erosion process. Sediment is, therefore, defined as any fragmented material, which is transported or deposited by water, ice, air or any other natural agent. From this, it is inferred that sedimentation is also the process of detachment, transportation and deposition of eroded soil particles. Thus, the natural sequence of the sediment cycle is as follows:

Soil → **detachment** → **Transportation** → **Deposition**

Detachment is the dislodging of the soil particle from the soil mass by erosive agents. In case of water erosion, major erosive agents are impacting raindrops and runoff water flowing over the soil surface. Transportation is the entrainment and movement of detached soil particles (sediment) from their original location. Sediments move from the upland sources through the stream system and may eventually reach the ocean. Not all the sediment reaches the ocean; some are deposited at the base of the slopes, in reservoirs and flood plains along

the way. Erosion is almost universally recognized as a serious threat to human well being. Erosion reduces the productivity of crop land by removing and washing away of plant nutrients and organic matter. Distribution of global sediment load is presented in Fig. 1.2.



Source: Peter H. Gleick, *Water in Crisis*, New York Oxford University Press, 1993.

Fig. 1.2. Global sediment loads. Due to high monsoon rainfall, Asia has the highest suspended sediment discharge. (Source: Peter H.G., 1983)

1.1.2 Problems Arising due to Soil Erosion

Balanced ecosystems comprising soil, water and plant environments are essential for the survival and welfare of mankind. However, ecosystems have been disturbed in the past due to over exploitation in many parts of the world, including some parts of India. The resulting imbalance in the ecosystem is revealed through various undesirable effects, such as degradation of soil surfaces, frequent occurrence of intense floods etc.

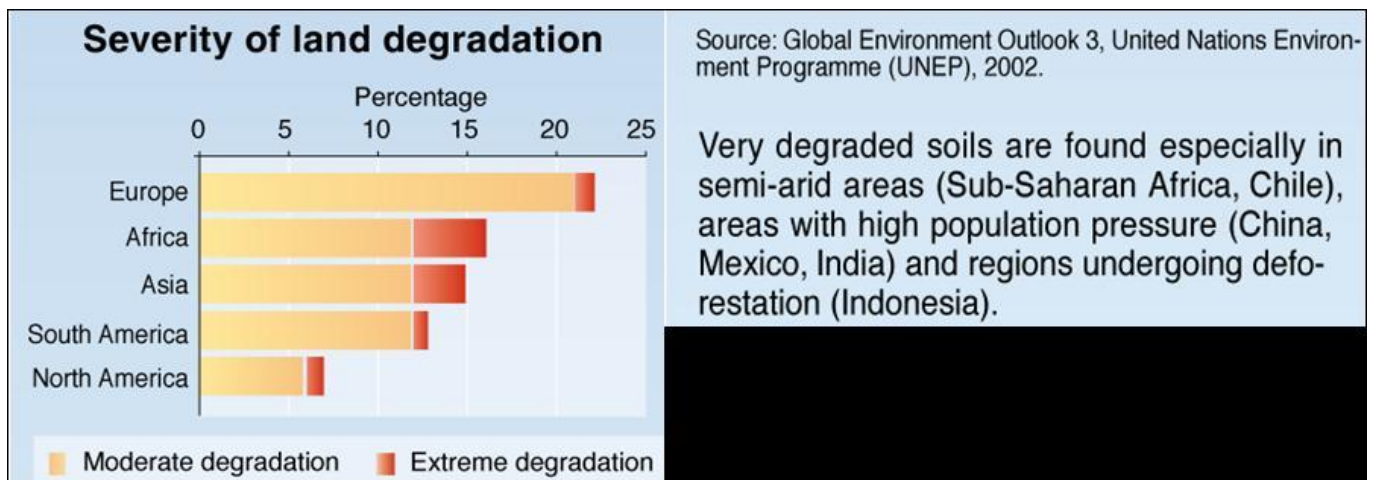

Fig. 1.3. Severity of land degradation at continental scale.

(Source: Peter H.G., 1983)

Vast tracts of land have been irreversibly converted into infertile surfaces due to accelerated soil erosion caused by the above and other factors. These degraded land surfaces have also become a source of pollution of the natural water. Deposition of soil eroded from upland areas in the downstream reaches of rivers has caused aggradation. This has resulted in an increase in the flood plain area of the rivers, reduction of the clearance below bridges and culverts and sedimentation of reservoirs. Severity of land degradation at a continental scale is shown in Fig. 1.3.

The major land degradation problems due to sedimentation are briefly discussed as below:

- Erosion by wind and water: Out of 144.12 M-ha areas affected by water and wind erosion. About 69 M-ha is considered to be critical and needs immediate attention. Wind erosion is mainly restricted to States of Rajasthan, Gujarat and Haryana. The severity of wind erosion is inversely related to the rainfall amount, lesser is the rainfall more would be the wind erosion.
- Gullies and Ravines: About 4 M-ha is affected by the problem of gullies and ravines in the country covering about 12 states. Ravines are mostly located in the states of Uttar Pradesh, Madhya Pradesh, Rajasthan and Gujarat. Gullies on the other hand are seen in the plateau region of Eastern India, foot hills of the Himalayas and areas of Deccan Plateau.
- Torrents and Riverine Lands: Problem of Riverine and torrents is spread over an area of 2.73 M-ha in the country. Torrents are the natural streams which cause extensive damage to life and property as a result of frequent changes in their course and associated flash flows with heavy debris loads. The unfertile material or debris transported by torrents is sometimes deposited on the fertile plains, thus ruining the land for ever.
- Water logging: Water logging is caused either by surface flooding or due to rise of water table. An area of 8.53 M-ha has been estimated to be affected by water logging. Water logging due to surface flooding is predominant in the states of West Bengal, Assam, Bihar, Orissa, Andhra Pradesh, Uttar Pradesh, Kerala, Punjab and Haryana.
- Shifting Cultivation: Shifting cultivation, also known as 'jhuming' is a traditional method of growing crops on hill slopes by slash and burn method. The method involves selection of appropriate site on hill slopes, cleaning of forest by cutting and burning, using the site for cultivation for few years and later on abandoning it and moving to a fresh site. The jhum cycle has gradually declined from 20-30 years to 3-6 years due to increasing population pressures. The problem is more serious in North Eastern region and in the states of Orissa and Andhra Pradesh.
- Saline soil including coastal areas: Saline soils are prevalent both in inland as well as coastal areas. About 5.5 M-ha area is affected by this problem in the country which includes arid and semi-arid areas of Rajasthan and Gujarat, black soil region and coastal areas. This problem is causing serious damage to agricultural lands, rendering fertile soil unproductive and turning groundwater brackish in the States of West Bengal, Tamil Nadu, Orissa, Maharashtra, Kerala, Karnataka, Gujarat and Andhra Pradesh as well as Union Territories of Pondicherry and Goa, Daman and Diu.
- Floods and Droughts: In India, among the major and medium rivers of both Himalayas and non-Himalayas categories, 18 are flood prone which drain an area of 150 M-ha. In recent years, flash floods have caused extensive damage even in the desert areas of Rajasthan and Gujarat.

1.1.3 Importance of Soil Conservation

In India, out of the total geographical area of 329 M-ha, an area of about 150 M-ha is subjected to either water or wind erosion. A net area of about 140 M-ha is cropped at present. An area of 40 M-ha is considered to be flood prone. Area lost through ravines and gullies is estimated to be about 4 M-ha. As a whole, it is estimated that about 175 M-ha i.e., 53.3% of the total geographical area of the country is subjected to various soil and land degradation problems like saline-alkali soils, waterlogged areas, ravine and gullied lands, area under shifting cultivation, and desertification. By the year 2100 A.D, the projected population of the country is expected to be two billion, whereas the food grain production is almost stagnant at 211 million tons for the last 5 years. The per capita cropped area is shrinking every day; in the year 1950, it was 0.33 ha/capita, 0.2 ha in 1980 and it was 0.15 ha by 2000. This clearly shows that the limited land resource has to be managed very carefully by adopting total conservation measures for the survival of the huge population. A few suggestions to conserve soil and water resources in Indian context are discussed below.

- To prevent erosion of bare soil, it is important to maintain a vegetation cover, especially in the most vulnerable areas e.g. those with steep slopes, in a dry season or periods of very heavy rainfall. For this purpose, only partial harvesting forests (e.g. alternate trees) and use of seasonally dry or wet areas for pasture rather than arable agricultural land should be permitted.
- Where intensive cultivation takes place, farmers should follow crop rotation in order to prevent the soil becoming exhausted of organic matters and other soil building agents. Where soils are ploughed in vulnerable areas, contour ploughing (i.e. round the hillside rather than down the hillside) should be used. Careful management of irrigation, to prevent the application of too much or too little water will be helpful to reduce the problem of soil salinity development. Livestock grazing must be carefully managed to prevent overgrazing.
- Construction of highways and urbanization should be restricted to areas of lower agricultural potential. With extractive industries, a pledge must be secured to restore the land to its former condition before permission for quarries or mines is granted.

1.1.4 History of Soil Erosion and Soil Conservation Programs in India

To meet the demand for food, fiber, fuel wood and fodder owing to increasing population pressures, the forest areas have been indiscriminately cleared resulting in enormous soil loss in many parts of the country. The human activities such as urbanization, road construction, mining etc. have further aggravated the problem. In the early years, the problem was more localized but now it has become more serious due to over exploitation of natural resources. However, various governmental plans have been implemented in the field of conservation of land, water and plant resources since pre-independence days.

(1) The Pre-Independence Era

In 1882, Sir Dietrich Brands, the Inspector General of Forests, commented on the possibility of soil erosion taking place and the need to counter it in the denuded slopes of the Nilgiri District of Madras Province of pre-independence India. He suggested planting of belts of trees in the midst of cultivation on hill slopes. Protection of land from the menace of 'Cho' (mountain torrents) also received early attention and one of the first enactments for prevention of soil deterioration was passed in Punjab in 1900 as Land Preservation Act. It provided for such measures as Wat Bandi (ridge formation), contour trenching, gully plugging, terracing, tree planting etc. for preventing the havoc caused by Chos. Soil conservation research in India was initiated during 1933-35 when the then Imperial (now

Indian) Council of Agricultural Research decided to establish its regional centres for research in dry farming at Sholapur (Maharashtra), Bijapur, Raichur, Bellary (Karnataka) and Rohtak (Haryana). Holding rain water by construction of bunds, green manuring, cultivation of kharif crops on shallow soils and fallowing in deep black soils were important measures recommended by the research stations.

A real push to soil conservation was given when a separate Soil Conservation Wing in Agricultural Department was established in Maharashtra during 1940's and massive contour bunding programme was taken up following scientific guidelines and specifications. Field bunding was also practiced as part of famine relief programmes in the Deccan plateau during 1930's and 40's. Soil conservation was not confined to contour bunding alone but also included nala bunding (check dams of loose stones) and percolation dams for water harvesting.

A commission was appointed by the Gwalior State as far back as 1919 to consider ways and means of arresting further extension of ravines and suggest methods for improving production of economic plants in these areas. In the 1930's, ravine reclamation practices were applied in the Chambal ravines of the erstwhile state of Gwalior. In 1953, Board of Agriculture made a proposal for a systematic reconnaissance survey of Indian soils to assess the damage caused by erosion. The Bombay Land Improvement Act of 1942 provided for setting up in each division a Land Improvement Board for conservation, improvement and regulation of agriculture, forest and pasture lands.

In 1945, the Central Government obtained the services of Dr. Donald V. Shuhart of Soil Conservation Service, USDA to report on soil erosion problems in India and suggest remedial measures. A high powered seven member team visited United States in May, 1947 for exhaustive study of soil conservation practices and submitted a report to Government of India taking due cognizance of the conditions peculiar to the Indian Agriculture. The team suggested that the unit of planning should be a village or a group of villages or a watershed. The report also emphasized that there should be a close cooperation between the Department of Forest, Agriculture and Irrigation at the centre and in the provinces in initiating and developing different phases of the conservation programme.

(2) Post-Independence Period

A conference of state Ministers in-charge of agriculture and cooperation was held in New Delhi in September, 1953. The conference considered that at the state level, existing organizations and state development committees should be entrusted with the task of formulating soil conservation programmes. It also suggested that any state problem with regard to soil conservation should be concern of the Central Soil Conservation Board. The central Government in the Ministry of Food and Agriculture set up a Central Soil Conservation Board in 1953. Maharashtra state did pioneering work on problems of soil erosion and conservation measures in cultivated lands. It was realized that ultimate aim of soil conservation was not only to control erosion but also to maintain the productivity of soil.

(3) First Five Year Plan (1951-56)

During the First Five Year Plan (1951-56), considerable attention was given to soil and moisture conservation. With a view to develop a research base for soil conservation, a Soil Conservation Branch and a Desert Afforestation Research Station at Jodhpur were established under the control of Forest Research Institute, Dehra Dun. Consequently, the

Central Soil Conservation Board established a chain of nine Soil Conservation Research, Demonstration and Training Centers at Dehra Dun, Chandigarh, Bellary, Ootacamund (now Udhagamandalam), Kota, Vasad, Agra, Chatra (Nepal) and Jodhpur during the late First Five Year Plan and early Second Five Year Plan.

(4) Second Five Year Plan (1956-61)

In this plan, the Desert Afforestation and Soil Conservation Centre at Jodhpur were developed into the Central Arid Zone Research Institute (CAZRI) in 1959 with collaboration of UNESCO. A Centre was set up at Chatra in Nepal to take-up research on soil conservation problems of Kosi River Valley Project. The All India Soil & Land Use Survey Organization was established at central level.

(5) Third Five Year Plan (1961-66)

A centre at Ibrahimpatnam (Hyderabad) in the semi-arid red soil region was established in the third five year plan in 1962. The Government of India reorganized the Soil Conservation Division in the Ministry of Agriculture and redesignated the Senior Director as Advisor and entrusted him with the responsibility of coordinating the soil and water conservation development. After the reorganization of Agricultural Research and Education in India, all the Soil Conservation Research, Demonstration and Training Centres of the Government of India except Chatra (Nepal) were transferred to the Indian Council of Agricultural Research (ICAR) on the 1st October, 1967.

(6) Fourth Five Year Plan (1969-74)

Under this plan, All India Soil & Land Use Survey prepared a detailed analysis of different watersheds of the country. The concept of Integrated Watershed Management was successfully introduced at field level in different parts of the country.

(7) Fifth Five Year Plan (1974-79)

In this plan, the Government of India introduced many centrally sponsored programmers, viz; Drought Prone Area Programme (DPAP), Flood Prone Area Programme (FPAP), Rural Development Programme (RDP), and Desert Development Programme (DDP). In DPAP and DDP, the focus was on planting of trees on degraded lands and to drill tube wells to extract groundwater.

(8) Sixth Five Year Plan (1980-85)

In this plan period, more emphasis was given on the treatment of small watersheds varying in size up to 2000 hectare. An intensive programme for integrated management of about 200 sub-watersheds of 8 flood prone catchments of Ganga river basin was undertaken during this plan.

(9) Seventh Five Year Plan (1985-90)

In this plan, DDP in hot and cold desert areas took a major establishment and afforestation practices were adopted on a large scale following integrated watershed management approach. On the basis of the experience gained in various schemes, National Watershed Development Programme for Rainfed Areas (NWDPR) was launched in the 7th Plan in 99 selected districts in the country. NWDPR was implemented in about 2550 watersheds in 357 districts of 25 states and two Union Territories, viz; Andaman and Nicobar Islands and

Dadra and Nagar Haveli. The watershed approach has the advantage of serving the twin objectives of restoration of ecological balance and socio-economic welfare of watershed community.

(10) Eighth Five Year Plan (1990-95)

During this period, Ministry of Agriculture, Department of Agriculture and Cooperation, New Delhi formulated the guidelines for the implementation of NWDPR and published it in the form of a document commonly known as WARASA (Watershed Areas Rainfed Agriculture System Approach). The Ministry of Rural Development also brought out common guidelines for the implementation of DPAP, DDP and Integrated Wasteland Development Programme (IWDP) in the country so as to maintain uniformity in objectives, strategies and expenditure norms for various watershed development projects.

(11) Ninth Five Year Plan (1997-02)

The centrally sponsored scheme for reclamation of alkali soils was launched during the Seventh Five Year Plan in the states of Haryana, Punjab and Uttar Pradesh. It continued during the Eighth Five Year Plan and was extended to the states of Gujarat, Madhya Pradesh and Rajasthan. During 2000-01, it was extended to all other states where alkali soil problem exists. The scheme aimed at improving physical conditions and productivity status of alkali soils for restoring optimum crop production. The major components were assured irrigation water, on-farm development works like land leveling, bunding and ploughing, community drainage system, application of soil amendments, organic manures etc. During IX Plan, an area of 0.97 lakh ha, mostly occurring in isolated patches, was reclaimed at a cost of Rs. 14.99 crores (Govt. of India share).

Up to IX plan (1997-02), an area of 426 lakh ha had been covered under Priority Delineation Survey (PDS) and about 13.1 lakh ha under Detailed Soil Survey (DSS) by the All India Soil and Land Use Survey.

(12) Tenth Five Year Plan (2002-07)

The Tenth Five Year Plan (2002-2007) has put emphasis on natural resource management through rainwater harvesting, groundwater recharging measures and controlling groundwater exploitation, watershed development, treatment of waterlogged areas. The Government of India fully funded the Western Ghats Development Programme (WGDP), area affected due to erosion and water problem. In this programme, the State Governments were directed to adopt Integrated Watershed Approach in implementing the activities such as soil conservation, agriculture, horticulture, afforestation, fuel and fodder development, minor irrigation, animal husbandry etc. various soil conservation measures (engineering and agricultural) like construction of check dams, gully plugging, plantation of mixed species and contour trenching etc were taken up in sensitive Western Ghats areas of Sattari, Canacona and Sanguem talukas.

(13) Eleventh Five Year Plan (2007-12)

Watershed development projects, for the purpose of conserving soil and water, were funded through various schemes including National Watershed Development Projects in Rainfed Areas (NWDPR), River Valley Projects (RVP), and Integrated Wasteland Development Programme (IWDP). Emphasis has been given to increase the water resources availability

and their efficient use. Responsibility for ensuring adequate availability of water for agricultural use was divided between the Ministry of Water Resources (MoWR), which was responsible for major, medium, and minor irrigation, the Department of Land Resources, which was responsible for watershed management, the Department of Rural Development, which was responsible for the Mahatma Gandhi Rural Employment Guarantee Act (MGNREGA) and strongly oriented to deal with water conservation issues, and the Department of Agriculture, which deals with water use efficiency.



AGRIMOON.COM

All About Agriculture...

Lesson 2 Principles of Soil Erosion

2.1 Causes of Soil Erosion

No single unique cause can be held responsible for soil erosion or assumed as the main cause for this problem. There are many underlying factors responsible for this process, some induced by nature and others by human being. The main causes of soil erosion can be enumerated as:

(1) Destruction of Natural Protective Cover by

- (i) indiscriminate cutting of trees,
- (ii) overgrazing of the vegetative cover and
- (iii) forest fires.

(2) Improper Use of the Land

- (i) keeping the land barren subjecting it to the action of rain and wind,
- (ii) growing of crops that accelerate soil erosion,
- (iii) removal of organic matter and plant nutrients by injudicious cropping patterns,
- (iv) cultivation along the land slope, and
- (v) faulty methods of irrigation.

2.2 Types of Soil Erosion

2.2.1 According to Origin: Soil erosion can broadly be categorized into two types i.e. geologic erosion and accelerated erosion.

2.2.2 Geological Erosion: Under natural undisturbed conditions an equilibrium is established between the climate of a place and the vegetative cover that protects the soil layer. Vegetative covers like trees and forests retard the transportation of soil material and act as a check against excessive erosion. A certain amount of erosion, however, does take place even under the natural cover. This erosion, called geologic erosion, is a slow process and is compensated by the formation of soil under the natural weathering process. Its effect are not of much consequence so far as agricultural lands are concerned.

2.2.3 Accelerated Erosion: When land is put under cultivation, the natural balance existing between the soil, its vegetation cover and climate is disturbed. Under such condition, the removal of surface soil due to natural agencies takes places at faster rate than it can be built by the soil formation process. Erosion occurring under these condition is referred to as accelerated erosion. Its rates are higher than geological erosion. Accelerated erosion depletes soil fertility in agricultural land.

2.2.4 According to Erosion Agents: Soil erosion is broadly categorized into different types depending on the agent which triggers the erosion activity. Mentioned below are the four main types of soil erosion.

(1) Water Erosion: Water erosion is seen in many parts of the world. In fact, running water is the most common agent of soil erosion. This includes rivers which erode the river basin, rainwater which erodes various landforms, and the sea waves which erode the coastal areas. Water erodes and transports soil particles from higher altitude and deposits them in low lying areas. Water erosion may further be classified, based on different actions of water responsible for erosion, as : (i) raindrop erosion, (ii) sheet erosion, (iii) rill erosion, (iv) gully erosion, (v) stream bank erosion, and (vi) slip erosion.

(2) Wind Erosion: Wind erosion is most often witnessed in dry areas wherein strong winds brush against various landforms, cutting through them and loosening the soil particles, which are lifted and transported towards the direction in which the wind blows. The best example of wind erosion are sand dunes and mushroom rocks structures, typically found in deserts.

(3) Glacial Erosion: Glacial erosion, also referred to as ice erosion, is common in cold regions at high altitudes. When soil comes in contact with large moving glaciers, it sticks to the base of these glaciers. This is eventually transported with the glaciers, and as they start melting it is deposited in the course of the moving chunks of ice.

(4) Gravitational Erosion: Although gravitational erosion is not as common a phenomenon as water erosion, it can cause huge damage to natural, as well as man-made structures. It is basically the mass movement of soil due to gravitational force. The best examples of this are landslides and slumps. While landslides and slumps happen within seconds, phenomena such as soil creep take a longer period for occurrence.

2.3 Agents of Soil Erosion

Soil erosion is the detachment of soil from its original location and transportation to a new location. Mainly water is responsible for this erosion although in many locations wind, glaciers are also the agents causing soil erosion. Water in the form of rain, flood and runoff badly affects the soil. Soil is in fact a composite of sand, silt and clay. When the rain falls along the mountains and bare soil, the water detaches the soil particles, and takes away the silt and clay particles along with the flowing water. Similarly, when wind blows in the form of storms, its speed becomes too high to lift off the entire soil upper layer and causes soil erosion.

Other factors responsible for soil erosion are human and animal activities. Vegetation is the natural cover of soil. When the animals continuously graze in the pastures, the vegetation is removed due to their walking and grazing. Bare lands left behind are easily affected by soil erosion. Activities of human like forest cutting, increased agriculture, and clearing of land for different purposes are the other agents that cause erosion of the soil. The soil erosion agent can be classified and summarized as shown in Fig. 2.1.

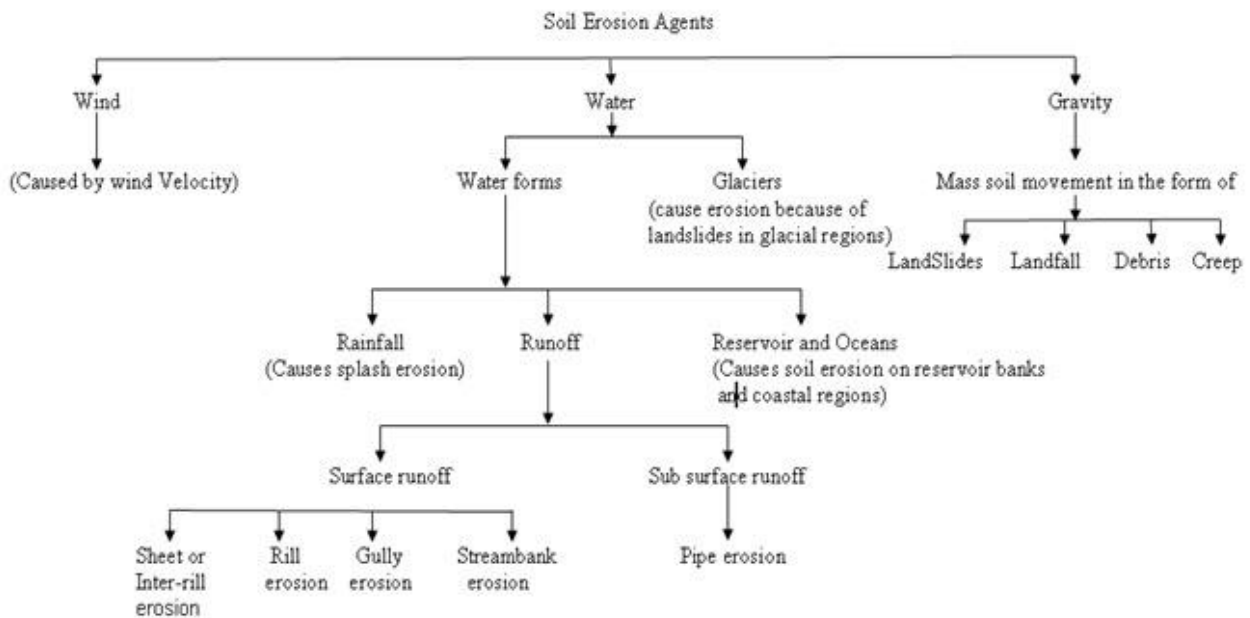

Fig. 2.1. Soil erosion agents, processes and effects. (Sources: Das, 2000)

2.4 Factors Affecting Soil Erosion

Soil erosion includes the processes of detachment of soil particles from the soil mass and subsequent transport and deposition of those soil/sediment particles. The main factors responsible for soil erosion, in India, are excessive deforestation, overgrazing and faulty agricultural practices. Soil erosion is a very complicated problem as many complex factors affect the rate of erosion and therefore it is difficult to solve. These factors include:

1. Climatic Factor: The climatic factors that influence erosion are rainfall amount, intensity, and frequency. During the periods of frequent or continuous rainfall, high soil moisture or saturated field conditions are developed, a greater percentage of the rainfall is converted into runoff. This in turn results in soil detachment and transport causing erosion at high rate.

2. Temperature: While frozen soil is highly resistant to erosion, rapid thawing of the soil surface brought about by warm rains can lead to serious erosion. Temperature also influences the type of precipitation. Although falling snow does not cause erosion, heavy snow melts in spring can cause considerable runoff damage. Temperature also influences the amount of organic matter that get collected on the ground surface and get incorporated with the topsoil layer. Areas with warmer climates have thinner organic cover on the soil. Organic matter cover on the surface protects the soil by shielding it from the impact of falling rain and helping in the infiltration of rainfall that would otherwise cause more runoff. Organic matter inside the soil increases permeability of the soil to cause more percolation and reduce runoff.

3. Topographical Factors: Among the topographical factors, slope length, steepness and roughness affect erodibility. Generally, longer slope increases the potential for erosion. The greatest erosion potential is at the base of the slope, where runoff velocity is the greatest and runoff concentrates. Slope steepness, along with surface roughness, and the amount and intensity of rainfall control the speed at which runoff flows down a slope. The steeper the slope, the faster the water will flow. The faster it flows, the more likely it will cause erosion and increase sedimentation. Slope accelerates erosion as it increases the velocity of flowing water. Small differences in slope make big difference in damage. According to the laws of

hydraulics, four times increase in slope doubles the velocity of flowing water. This doubled velocity can increase the erosive power four times and the carrying (sediment) capacity by 32 times.

4. Soil: Physical characteristics of soil have a bearing on erodibility. Soil properties influencing erodibility include texture, structure and cohesion. Texture refers to the size or combination of sizes of the individual soil particles. Three broad size classifications, ranging from small to large are clay, silt, and sand. Soil having a large amount of silt-sized particles is most susceptible to erosion from both wind and water. Soil with clay or sand-sized particles is less prone to erosion.

Structure refers to the degree to which soil particles are clumped together, forming larger clumps and pore spaces. Structure influences both the ability of the soil to absorb water and its physical resistance to erosion. Another property is the cohesion which refers to the binding force between the soil particles and it influences the structure. When moist, the individual soil particles in a cohesive soil cling together to form a doughy consistency. Clay soils are very cohesive, while sand soils are the least cohesive.

5. Vegetation: Vegetation is probably the most important physical factor influencing soil erosion. A good cover of vegetation shields the soil from the impact of raindrops. It also binds the soil together, making it more resistant to runoff. A vegetative cover provides organic matter, slows down runoff, and filters sediment. On a graded slope, the condition of vegetative cover will determine whether erosion will be stopped or only slightly halted. A dense, robust cover of vegetation is one of the best protections against soil erosion.

6. Biological Factors of Soil Erosion: Biological factors that influence the soil erosion are the activities like faulty cultivation practices, overgrazing by animals etc. These factors may be broadly classified into following three groups: (i) Energy factors, (ii) Resistance factors, and (iii) protection factors.

(i) Energy Factors: They include such factors which influence the potential ability of rainfall, runoff and wind to cause erosion. This ability is termed as erosivity. The other factors which directly reduce the power of erosive agents are reduction in length/degree of slope through the construction of terraces and bunds in case of water eroded areas and creation of wind breaks or shelter belts in case of wind eroded areas.

(ii) Resistance Factors: They are also called erodibility factors which depend upon the mechanical and chemical properties of the soil. Those factors which enhance the infiltration of water into the soil reduce runoff and decrease erodibility, while any activity that pulverizes the soil increases erodibility. Thus, cultivation may decrease the erodibility of clay soils but increases that of sandy soil.

(iii) Protection Factors: This primarily focuses on the factors related to plant cover. Plant cover protects the soil from erosion by intercepting the rainfall and reducing the velocity of runoff and wind. Degree of protection provided by different plant covers varies considerably. Therefore, it is essential to know the rate of soil erosion under different land uses, degrees of length and slope, and vegetative covers so that appropriate land use can be selected for each piece of land to control the rate of soil erosion. The quantity of soil moved past a point is called soil loss. It is usually expressed in unit of mass or volume per unit time per unit area.

2.5 Mechanics of Soil Erosion

Soil erosion is initiated by detachment of soil particles due to action of rain. The detached particles are transported by erosion agents from one place to another and finally get settled at some place leading to soil erosion process. Different soil erosion processes are shown in Fig. 2.2.

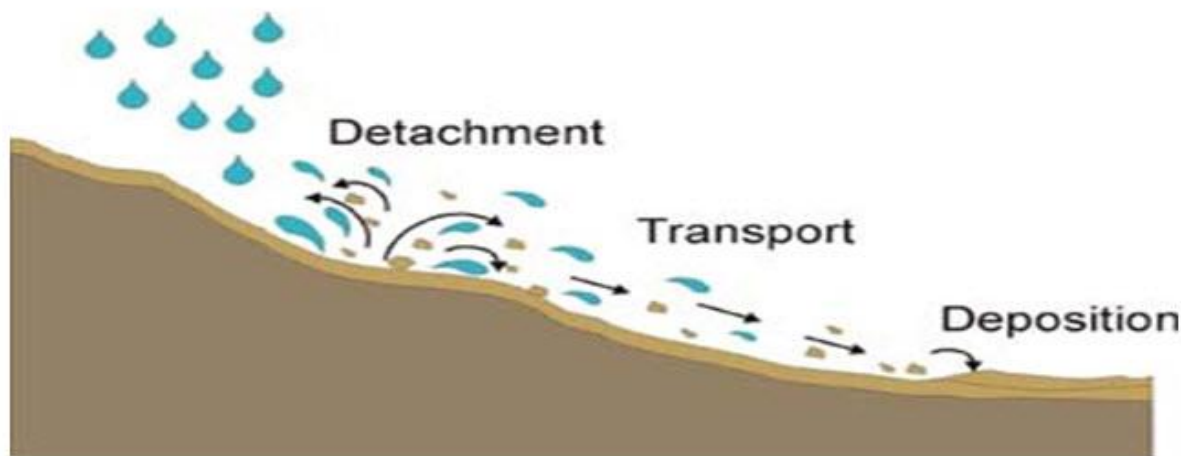

Fig. 2.2. Process of water erosion by the impact of raindrops.

Mechanics of soil erosion due to water and wind is discussed below.

2.5.1 Mechanics of Water Erosion

There are three steps for accelerated erosion by water:

- i) Detachment or loosening of soil particles caused by flowing water, freezing and thawing of the top soil, and/or the impact of falling raindrops,
- ii) Transportation of soil particles by floating, rolling, dragging, and/or splashing and
- iii) Deposition of transported particles at some places of lower elevation.

Rain enhances the translocation of soil through the process of splashing as shown in Fig.2.2. Individual raindrops detach soil aggregates and redeposit them as particles. The dispersed particles may then plug soil pores, reducing water intake (infiltration). Once the soil dries, these particles develop into a crust at the soil surface and runoff is further increased.

2.5.2 Mechanics of Wind Erosion

Wind erosion occurs where soil is exposed to the dislodging force of wind. The intensity of wind erosion varies with surface roughness, slope and types of cover on the soil surface and wind velocity, duration and angle of incidence. Fine soil particles can be carried to great heights and for (may be) hundreds of kilometers. The overall occurrence of wind erosion could be described in three different phases. These are initiation of movement, transportation and deposition.

1. Initiation of Movement: The initiation of the movement of soil particles is caused by several factors acting separately in combination. In the course of collision of grains rolling and bumping on the surface, some particles may be bounced up. It occurs when the wind force or the impact of moving particles is strong enough to dislodge stationary soil particles.

2. Transportation: The transportation of the particles once they are dislodged take place in three ways:

i) Saltation – In saltation soil particles of medium size (0.10-0.15 mm diameter) are carried by wind in a series of short bounces. These bounces are caused by the direct pressure of the wind on soil particles.

ii) Soil Creep – saltation also encourages soil creep (rolling or sliding) along the surface of the particles (0.5-1.0 mm diameter). The bouncing particles carried by saltation strike the large aggregates and speed up their movement along the surface.

iii) Suspension – When the particles of soil are very small (less than 0.1 mm) they are carried over long distances. Finer suspended particles are moved parallel to the ground surface and upward.

3. Deposition: Deposition of the particles occurs when the gravitational force is greater than the forces holding the particles in air. Deposition could occur when the wind velocity is decreased due to surface obstructions or other natural causes.



AGRIMOON.COM

All About Agriculture...

Lesson 3 Erosion Due to Water

Erosion of soil by water is caused by its two forms: liquid as the flowing water, and solid as the glaciers.

3.1 Forms of Water Erosion

The impact of rainfall causes splash erosion. Runoff water causes scraping and transport of soil particles leading to sheet, rill and gully erosion. Water waves cause erosion of bank sides of reservoirs, lakes and oceans. The subsurface runoff causes soil erosion in the form of pipe erosion, which is also called tunnel erosion. The glacial erosion causes heavy landslides. In India, glacial erosions are mainly confined to Himalayan regions. The various forms of water erosion are given below.

3.1.1 Hydraulic Action: The hydraulic action takes place when water runs over the soil surface compressing the soil, as a result of which the air present in the voids exerts a pressure on the soil particles and this leads to the soil detachment. The pressure exerted by the air voids is called hydraulic pressure. The soil particles so detached from their places, are scoured by the running water. The hydraulic action is more effective when the soil is in loose condition.

3.1.2 Abrasion: Soil particles mixed with the running water create an abrasive power in the water which increases the capacity of flowing water to scour more soil particles. Due to this effect, larger soil particles are eroded by the flowing water.

3.1.3 Attrition: This form includes mechanical breakdown of loads running along the moving water due to collision of particles with each other. The broken particles are moved along with the flow velocity, which generate abrasion effect on the bottom and banks of the water course. This effect pronounces the water erosion.

3.1.4 Solution: This form is associated with the chemical action between running water and soil or country rocks. This type condition is observed in areas where existing rocks or soils are easily dissolved in the running water.

3.1.5 Transportation: The process of soil transportation by running water is completed under the following forms:

- 1) **Solution:** the water soluble contents present in the water are transported by the water in solution form.
- 2) **Suspension:** it involves the transportation of finer soil particles, which are present in suspension form in the flowing water.
- 3) **Saltation and Surface Creep:** it involves transportation of medium size soil particles that are not able to stand in suspension form, but are mixed in water and flow over the stream bed in the form of mud. The surface creep action is responsible for transporting the coarser soil particles.

3.2 Factors Affecting Water Erosion

Water erosion is due to dispersive and transporting power of the water; as in case of water erosion first soil particles are detached from the soil surface by the raindrop force and then transported with surface runoff. There is a direct relationship between the soil loss and surface runoff volume. The water erosion process is influenced primarily by climate, topography, soils and vegetative cover. The factors influencing the water erosion are discussed below.

3.2.1 Climatic Factors: Climate includes rainfall, temperature and wind. The frequency, intensity and duration of rainfall are the principal aspects of rainfall influencing the volume of runoff, erosion and sediment (potential) from a given area. As the volume and intensity of rainfall increase, the ability of water to detach and transport soil particles increases. When storms are frequent, intense, and of long duration, the potential for erosion of bare soils is high. Temperature has a major influence on soil erosion. Frozen soils are relatively erosion resistant. However, bare soils with high moisture content are subject to uplift or “spew” by freezing action and are usually easily eroded upon thawing. Wind contributes to the drying of soil and increases the need for irrigation for new plantings and for applying wind erosion control practices.

3.2.2 Soil Characteristics: Soil characteristics include texture, structure, organic matter content and permeability. In addition, in many situations, compaction is significant. These characteristics greatly determine the erodibility of soil. Soils containing high percentages of sand and silt are the most susceptible to detachment because they lack inherent cohesive characteristics. However, the high infiltration rates of sands either prevent or delay runoff except where overland flow is concentrated. Clearly, well-graded and well-drained sands are usually the least erodible soils in the context of sheet and rill erosion. Clay and organic matter act as a binder to soil particles, thus reducing erodibility. As the clay and organic matter content of soils increase, the erodibility decreases. However, while clays have a tendency to resist erosion, they are easily transported by water once detached. Soils high in organic matter resist raindrop impact, and the organic matter also increases the binding characteristics of the soil. Sandy and silty soils on slopes are highly susceptible to gully erosion where flow concentrates because they lack inherent cohesiveness. Small clay particles, referred to as colloids, resist the action of gravity and remain in suspension for long periods of time. Colloids are potentially a major contributor to turbidity where they exist.

3.2.3 Vegetation Cover: Vegetative cover is an extremely important factor in reducing erosion at a site. It absorbs energy of raindrops, binds soil particles, slows down the velocity of runoff water, increases the ability of a soil to absorb water, removes subsurface water between rainfall events through the process of evapotranspiration and reduces off-site fugitive dust. By limiting the amount of vegetation disturbance and the exposure of soils to erosive elements, soil erosion can be greatly reduced. Vegetations create a surface obstruction for direct falling of raindrops on the land surface as well as in the flowing path of surface runoff. A good vegetative cover completely negates the effect of rainfall on soil erosion.

3.2.4 Topographic Effect: The main topographic factors which influence the soil erosion are land slope, length of slope and shape of slope. The land slope or slope inclination affects the erosion predominantly. As the slope increases, the runoff coefficient, kinetic energy and carrying capacity of surface runoff also increase thereby decreasing the soil stability. Critical slope length is the slope length at which the soil erosion begins. It is related to the critical

land inclination. Lower the critical inclination larger will be the critical slope length. The slope shapes have greater bearing on erosion potential. The base of a slope is more susceptible to erosion than the top, because runoff has more momentum and is more concentrated as it approaches the base of slope. The slopes may be roughly convex or concave. On convex slope the above phenomena is magnified, whereas on concave slope it is reduced. It is because in convex slope, the steepness increases towards bottom, while it is flattened towards bottom in case of concave slope.

3.3 Types of Water Erosion

Water erosion can be classified as splash erosion, sheet erosion, rill erosion, gully erosion, stream bank erosion, sea-shore erosion and land slide erosion. They are discussed as follows.

3.3.1 Splash Erosion: It is also known as raindrop erosion (Fig. 3.1) because it is caused by the impact of raindrops on exposed soil surface. The process of raindrop erosion can be described as: when raindrop strikes on open soil surface it forms a crater. This is accomplished by forming a blast which bounces the water and soil up and returns back around the crater. The soil may be splashed into the air up to a height of 50 to 75 cm depending upon the size of rain drops. At the same time the soil particles also move horizontally as much as 1.50 m on level land surface. On sloping land, more than half of the splashed particles move down with the runoff.

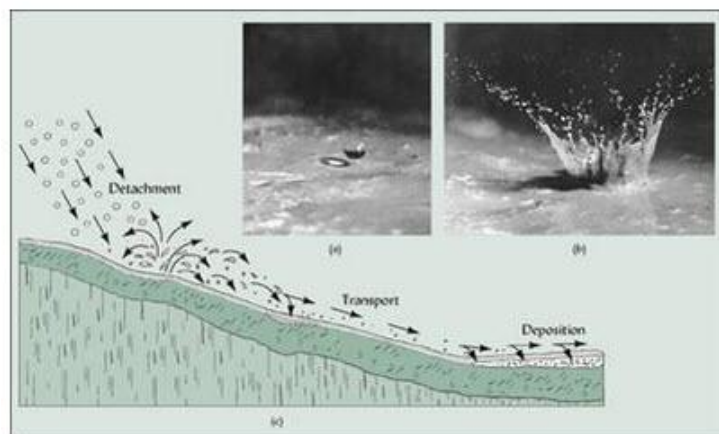

Fig. 3.1. Splash erosion.

3.3.2 Sheet Erosion: Sheet erosion may be defined as more or less uniform removal of soil in the form of a thin layer or in “sheet” form by the flowing water from a given width of sloping land (Fig. 3.2). It is an inconspicuous type of soil erosion because the total amount of soil removed during any storm is usually small. In the sheet erosion two basic erosion processes are involved. First process is the one in which soil particles are detached from the soil surface by falling of raindrop and in the second one the detached soil particles are transported away by surface runoff from the original place. The detached process is referred to as the splash erosion and transportation of detached particles by flowing water is considered as the wash erosion. When the rate of rainfall exceeds the infiltration rate of the soil, the excess water tends to flow over the surface of sloping land. This flowing water also detaches soil particles from the land surface and starts flowing in the form of thin layer over the surface. The erosion during these processes is called sheet erosion. The eroding and transporting power of sheet flow depends on the depth and velocity of flowing water for a given size, shape and density of soil particles.



Fig. 3.2. Sheet erosion.

3.3.3 Rill Erosion: This type of water erosion is formed in the cultivated fields where the land surface is almost irregular. As the rain starts, the water tends to accumulate in the surface depressions and begins to flow following least resistance path. During movement of water large amount of soil particles are eroded from the sides and bottom of the flow path, which are mixed in the flowing water. This surface flow containing soil particles in suspension form moves ahead and forms micro channels and rills (Fig. 3.3).



Fig. 3.3. Rill erosion.

3.3.4 Gully Erosion: Rills are small in size and can be leveled by tillage operations. When rills get larger in size and shape due to prolonged occurrence of flow through them and cannot be removed by tillage operation, these are called gullies (Fig. 3.4). Large gullies and their network are called ravines. It is the advanced and last stage of water erosion. In other words it is the advanced stage of rill erosion. If the rills that are formed in the field are overlooked by the farmers, then they tend to increase in their size and shape with the occurrence of further rainfall. Some of the major causes of gully erosion are: steepness of land slope, soil texture, rainfall intensity, land mismanagement, biotic interference with natural vegetation, incorrect agricultural practices, etc. Gully erosion gets initiated where

the longitudinal profile of an alluvial land becomes too steep due to sediment deposition. Gullies advance due to the removal of soil by the flowing water at the base of a steep slope, or a cliff at the time of fall of stream. High intensity of flow of the runoff increases the gully dimensions. In the absence of proper control measures, slowly the gullies extend to nearby areas and subsequently engulf the entire region with a network of gullies of various sizes and shapes.



Fig. 3.4. Gully erosion.

3.3.5 Stream Bank Erosion: Stream bank erosion is defined as the removal of stream bank soil by water either flowing over the sides of the stream or scouring from there (Fig.3.5). The stream bank erosion due to stream flow in the form of scouring and undercutting of the soil below the water surface caused by wave action is a continuous process in perennial streams. Stream bank erosion is mainly aggravated due to removal of vegetation, over grazing or cultivation on the area close to stream banks. Stream bank erosion is also caused by the occurrence of flood in the stream. Apart from scouring, the sloughing is also a form of stream bank erosion which is caused when the stream water subsides after reaching the peak. Sloughing is mainly due to movement of underground water from side into the stream due to pressure difference.



Fig. 3.5. Stream bank erosion.

3.3.6 Sea-shore Erosion: It is also called coastal erosion. Sea shore erosion is the wearing away of land and the removal of beach or dune sediments by wave action, tidal currents,

wave currents, or drainage (Fig. 3.6). Waves, generated by storms, wind or fast moving motor craft, cause coastal erosion which may take the form of long-term losses of sediment and rocks, or merely the temporary redistribution of coastal sediments. It may be caused by hydraulic action, abrasion, impact and corrosion.



Fig. 3.6. Sea-shore/ coastal erosion.

3.3.7 Landslide Erosion: When gravity combines with heavy rain or earthquakes, whole slopes can slump, slip or slide (Fig. 3.7). Slips occur when the soil (topsoil and subsoil) on slopes becomes saturated. Unless held by plant roots to the underlying surface, it slides downhill, exposing the underlying material.

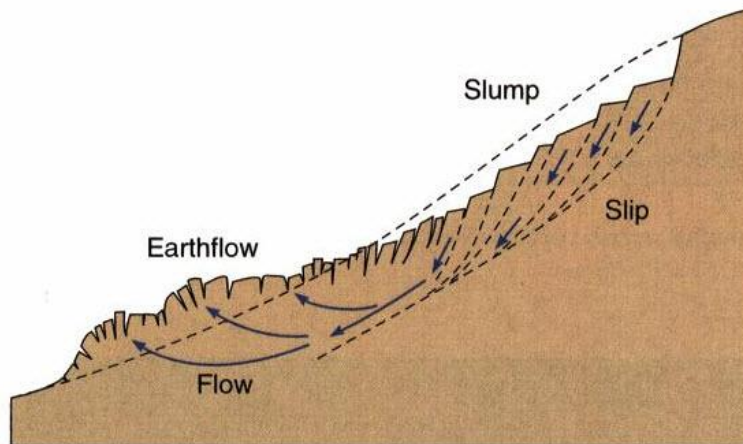

Fig. 3.7. Cross-section of landslide characteristics.



Lesson 4 Agronomical Measures for Water Erosion Control

4.1 Mechanics of Water Erosion Control

The different geological actions generated by the flowing water over the land surface by which soil erosion take place may be described as below.

(a) Hydraulic Action: when water runs over the soil surface then it compresses the soil, as a result the air present in the voids exerts a pressure on the soil particles, which leads to the soil detachment. The pressure exerted by the air present in the voids is known as hydraulic pressure. The soil particles detached in this process from their places, are scoured by the running water. The hydraulic action is more effective, especially when soil is in loose condition.

(b) Abrasion: In this geologic action, the soil particles mixed the running water, create an abrasive power in the water by which the capacity of flowing water to scour the soil particles get increased. Due to this effect greater soil particles are eroded by flowing water. The river bank erosion and erosion from bottom of the valley are results of abrasion action of running water.

(c) Attrition: This action includes the mechanical breakdown of loads running along the moving water due to collision of particles with each other. It can be expressed in other way that when big size rock fragments, boulders or pebbles are present in the moving water of streams or river, then they are broken due to striking actions with each other. The broken particles are moved along with the flowing water. They generate abrasion effects on the bottom and banks of the water course. This effect pronounces the water erosion.

(d) Solution: This process is associated with the chemical action between the running water and soil/rocks. Occurrence of this type of erosion is observed in those areas, where existing rocks/soil are easily dissolved in the water. Actually due to this action, the soil or rock materials are dissolved in the running water due to chemical action and are carried away along the water flow.

(e) Transportation: It is the process by which soil particles which are dissolved in the running water are carried away from one place to another. The transportation of particles depends upon the velocity of running water load present in the water, impediments/obstacles present in flow path of water and carrying capacity of running water. During water erosion, the process of soil transportation by running water is completed under the following forms:

i) **Solution:** The water soluble contents present in the water are transported by the water in solution form. Normally, certain dissolved chemicals such as calcium carbonate etc. derived from rocks are transported in solution form by the running water.

ii) **Suspension:** Suspension process involves the transportation of finer soil particles present in suspension form in the flowing water.

iii) **Saltation and Surface Creep:** The saltation mechanism is responsible to transport the medium size soil particles which can not be carried in suspension form due to their large

sizes, but are mixed in water and flow over the stream bed in the form of mud. The saltation and surface creep share a major part of sediment load, transported by running water. The transportation of soil particles by the surface creep action takes place for the coarser soil particles activated through the actions of jumping, collision and creeping.

(f) Deposition: The deposition of load mixed in the running water take place under following conditions:

i) The force acting in the direction of water flow and responsible for transport of the load becomes very less compared to the resisting force acting in the opposite direction, then the materials get deposited on the bed.

ii) Presence of surface obstruction such as trees, shrubs etc. in the flow path of running water tends to reduce the velocity of running water and as a result the soil load mixed in the water gets deposited.

Whenever there is meandering of the river or the stream, the velocity of flow on the concave side of the river reduces drastically and deposition of the load occurs on that side.

4.2 Agronomical Measures of Water Erosion Control

Soil conservation is a preservation technique, in which deterioration of soil and its losses are eliminated or minimized by using it within its capabilities and applying conservation techniques for protection as well as improvement of soil. In soil and water conservation, the agronomical measure is a more economical, long lasting and effective technique. Agronomic conservation measures function by reducing the impact of raindrops through interception and thus reducing soil erosion. They also increase infiltration rates and thereby reduce surface runoff. Widely used agronomic measures for water erosion control are listed below.

4.2.1 Contour Cropping

Contour Cropping is a conservation farming method that is used on slopes to control soil losses due to water erosion. Contour cropping involves planting crops across the slope instead of up and down the slope (Fig. 4.1). Use of contour cropping protects the valuable top soil by reducing the velocity of runoff water and inducing more infiltration. On long and smooth slope, contour cropping is more effective as the velocity of flow is high under such situation and contour cropping shortens the slope length to reduce the flow velocity. Contour cropping is most effective on slopes between 2 and 10 percent.



Fig. 4.1. Contour cropping. (Source: www.studyblue.com)

4.2.2 Strip Cropping

Strip cropping is the practice of growing strip of crops having poor potential for erosion control, such as root crop (intertilled crops), cereals, etc., alternated with strips of crops having good potentials for erosion control, such as fodder crops, grasses, etc., which are close growing crops (Fig. 4.2). Strip cropping is a more intensive farming practice than contour farming. The farming practices that are included in this type of farming are contour strip farming, cover cropping, farming with conservation tillage and suitable crop rotation. A crop rotation with a combination of intertilled and close growing crops, farmed on contours, provides food, fodder and conserves soil moisture. Close growing crops act as barriers to flow and reduce the runoff velocity generated from the strips of intertilled crops, and eventually reduce soil erosion. Strip cropping is laid out by using the following three methods:



Fig. 4.2. Strip cropping.

- i) **Contour strip cropping:** In contour strip cropping, alternate strips of crop are sown more or less following the contours, similar to contouring. Suitable rotation of crops and tillage operations are followed during the farming operations.
- ii) **Field strip cropping:** In a field layout of strip cropping, strip of uniform width are laid out across the prevailing slope, while protecting the soil from erosion by water. To protect the soil from erosion by wind, strips are laid out across the prevailing direction of wind. Such practices are generally followed in areas where the topography is very irregular, and the contour lines are too curvy for strict contour farming.
- iii) **Buffer strip cropping:** Buffer strip cropping is practiced where uniform strip of crops are required to be laid out for smooth operations of the farm machinery, while farming on a contour strip cropping layout. Buffer strip of legumes, grasses and similar other crops are laid out between the contour strips as correction strips. Buffer strips provide very good protection and effective control of soil erosion.

4.2.3 Mulching

Mulches are used to minimize rain splash, reduce evaporation, control weeds, reduce temperature of soil in hot climates, and moderate the temperature to a level conducive to microbial activity. Mulches help in breaking the energy of raindrops, prevent splash and dissipation of soil structure, obstruct the flow of runoff to reduce their velocity and prevent sheet and rill erosion (Fig. 4.3). They also help in improving the infiltration capacity by maintaining a conducive soil structure at the top surface of land.



Fig. 4.3. Mulching of cropped field.

4.2.3.1 Types of mulching material: To protect the land from erosion different types of materials are used as listed below.

1. Cut grasses or foliage
2. Straw materials
3. Wood chips
4. Saw dusts
5. Papers
6. Stones
7. Glass wools
8. Metal foils
9. Cellophanes
10. Plastics

The mulches may be broadly classified into the following five types:

1. **Synthetic mulch:** It includes organic and inorganic liquids that are sprayed on the soil surface to form a thin film for controlling the various atmospheric agents acting on the soil surface. The different synthetic mulching materials are: resins, asphalt emulsions, latex and cut back asphalt, canvas etc.
2. **Petroleum mulch:** The petroleum mulches are easier to apply and also less expensive. These mulches are available in the form of emulsions of asphalt in water, which can be sprayed on the soil surface at ambient temperature to form a thin film in continuous form that clings to soil, but does not penetrate deep inside the soil. The mulch film promotes uniform and rapid seed germination and also plays a significant role for vigorous growth of seedling. An ideal surface film is also stable against erosion, sufficiently porous to allow water into the soil, yet insoluble in water and resistant enough to the forces of weather, causing it to last as long as necessary for vegetation to become established.

3. **Conventional mulch:** The mulches such as hay or straw are more effective than the petroleum mulches. These mulches not only conserve the moisture and reduce the fluctuation of soil temperature, but also protect the soil from rain drop impacts and hold the excess surface water in contact with the soil, so as to increase the infiltration rate and thereby reduce the runoff and soil erosion. In addition, during day hours these mulches also absorb as much insolation as bare soil does, but little energy is conducted downward. This causes the surface of the mulch to become hot and the underlying soil to remain cool. On the other hand, during night hours, the mulch cools down permitting the soil to remain warm. The paper mulches also counted under conventional mulch are reported to produce remarkable results. Paper mulches are observed to increase the soil temperature, especially of the surface soil layers. There are several evidences to show that paper mulching gives better performance in improvement of soil condition, besides promoting the earthworm activity. But at the same time, caution has to be taken against the toxic elements of chemicals leached out of the paper. The bituminized treated papers have toxic effects on the plants.
4. **Stone mulch:** It involves the spreading of stone pieces on the ground surface to conserve the moisture and also to reduce the wind erosion. It is a very old practice, followed in arid zones. Soil under the stones tends to be in moist condition, but the temperature of that soil becomes slightly higher. The soils lying below the stones, harbor small animals and involve high nitrification. The stone mulching is also used for trapping the dew, particularly in those locations where significant dew fall takes place. Central arid zone research institute Jodhpur, has reported the use of rubble mulch, which is simply combination of small fragments of stones and bricks. This mulch provides better results on moisture conservation compared to the stone mulching, synthetic mulching and mulching made by straw materials.
5. **Organic mulch:** The tree branches, twigs, leaves, leaf litter, grasses, weeds etc. are used as organic mulch to cover the soil surface. The organic mulches are found superior to the artificial mulches in respect of conservation of moisture, reduction in evaporation and runoff. Use of this mulch controls the evaporation more effectively, particularly when rainfall takes place at frequent intervals, but it is not very effective when the numbers of rains are few and scattered. In other words, organic mulch does not conserve the moisture available due to infrequent rains and small showers, but these mulches may be quite effective for large rains lasting for several days which results in a wet surface with the availability of excess surface water for deep percolation. Further, the light mulches are almost ineffective for controlling the evaporation, because moisture conserving efficiency of mulch is inversely related to their capacity to absorb water or to extract it from the soil by capillary action. Resistant mulches do not decay shortly but last for a long time. As a result they are more effective for conserving the soil moisture.



Lesson 5 Terraces for Water Erosion Control

One of the most effective actions that can take to mitigate the problem of an eroding slope is to break up the rate of water descent by constructing terraces. The terraces for water erosion control consist of some mechanism to protect land surface as well as to reduce the erosive velocity of runoff water. It involves some land surface modification for retention and safe disposal of rainfall

5.1 Terraces and their Design

A Terrace is an earth-embankment, constructed across the slope, to control runoff and minimize soil erosion. A terrace acts as an intercept to land slope, and divides the sloping land surface into strips. In limited widths of strips, the slope length naturally available for runoff is reduced. It has been found that soil loss is proportional to the square root of the length of slope; i.e. by shortening the length of run, soil erosion is reduced. The soil eroded by the runoff scour and the raindrop splash flows down the slope, and gets blocked up by terraces. The scour of soil surface because of runoff water is initiated by the runoff at a velocity above the critical value, attained during a flow on long length of the sloping run. Thus, by shortening the length of run, the runoff velocity remains less than the critical value and therefore soil erosion owing to scour is prevented.

Terraces are classified into two major types: broad-base terraces and bench terraces. Broad-base terraces are adapted where the main purpose is either to remove or retain water on sloping land suitable for cultivation whereas, the purpose of bench terraces is mainly to reduce the land slope. The classification of the terraces is given in Fig. 5.1.

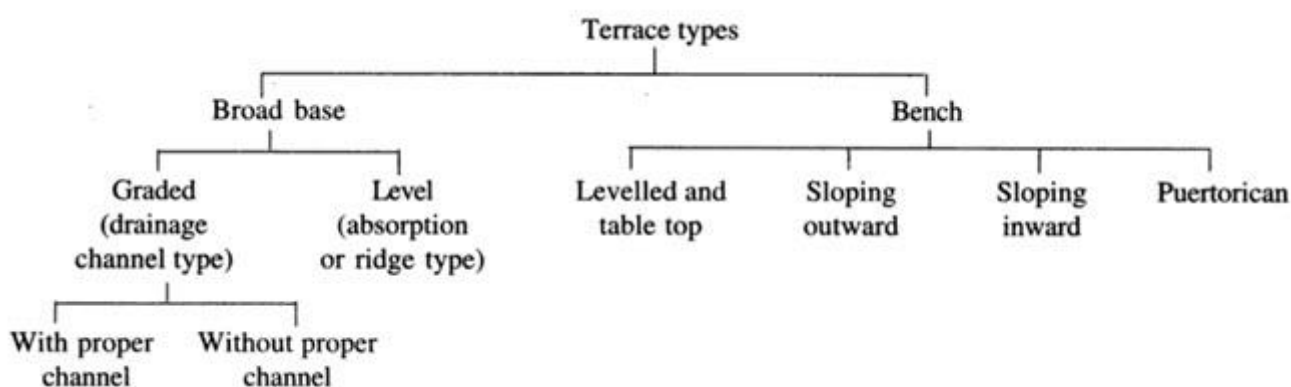

Fig. 5.1. Types of terraces.

5.2 Bench Terracing

The original bench terrace system consists of a series of flat shelf-like areas that convert a steep slope of 20 to 30 percent to a series of level, or nearly level benches (Fig. 5.2). In other words, bench terracing consists of construction of series of platforms along contours cut into hill slope in a step like formation. These platforms are separated at regular intervals by vertical drop or by steep sided and protected by vegetation and sometimes packed by stone retaining walls. In fact, bench terrace converts the long un-interrupted slope into several small strips and make protected platform available for farming. In several hilly areas bench

terraces have been used for the purpose of converting hill slopes to suit agriculture. In some areas where the climatic conditions favour the growing of certain cash crops like potato, coffee etc., the hill slopes are to be bench terraced before the area is put for cultivation of these crops. Bench terraces have also been adopted for converting sloping lands into irrigated fields or for orchard plantations.

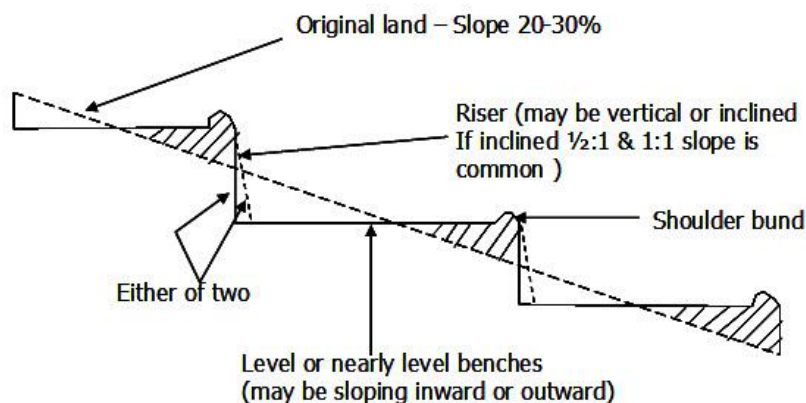

Fig. 5.2. Bench terrace and its different components.

5.3 Types of Bench Terraces

Depending on the purpose for which they are used, bench terraces are also classified as follows:

1. Hill-type bench terraces: used for hilly areas with a grade reversely towards the hill.
2. Irrigated bench terraces: level benches adopted under irrigated conditions.
3. Orchard bench terraces: narrow width terraces for individual trees. These are also referred to as intermittent terraces and step terraces.

The conversion of land into bench terraces over a period of time is referred to as gradual bench terracing. Bench terraces are classified depending upon the slope of benches. The different types are: (i) bench terraces sloping outward; (ii) bench terraces sloping inward and (iii) bench terraces with level top.

Bench terraces with slopes inside are to be adopted in heavy rainfall areas where a major portion of the rainfall is to be drained as surface runoff. In the case of these terraces, a suitable drain at the inward end of each of these terraces is to be provided to drain the runoff. These drains ultimately lead to a suitable outlet. These are also known as hill-type terraces. Bench terraces with level top are suitable for areas of medium rainfall, evenly distributed and having deep and highly permeable soils. Due to the fact that no slope is given to the benches it is expected that the most of the rainfall coming over the area is to be absorbed by the soil and very little water is to go as surface drainage. These types of terraces are also used where irrigation facilities are available and referred to as irrigated bench terraces. Bench terraces sloping outward are to be used in low rainfall areas with permeable soils. For bench terraces sloping outward a shoulder bund is essential even though such a bund is provided in the other two types also for giving stability to the edge of the terrace. In these terraces the rainfall thus conserved will have more time for soaking into the soil. Bench terraces with narrow width (about 1 m) are sometimes constructed for orchards bench terraces. These terraces are referred to as step terraces when a series of step like formations are made.

5.4 Design of Bench Terraces

For the designing of the bench terraces for a particular tract the average rainfall, the soil type, soil depth and the average slope of the area should be known. In addition the purpose for which the terraces are to be constructed should also be known. The design of bench terraces consists of determining the (1) type of the bench terrace, (2) terrace spacing or the depth of the cut, (3) terrace width, and (4) terrace cross section. Selection of the type of bench terrace among the three types, described earlier, depends upon the rainfall and soil conditions.

Terrace spacing is generally expressed as the vertical interval between two terraces. The vertical interval (D) is dependent upon the depth of the cut and since the cut and fill are to be balanced, it is equal to double the depth of cut. The factors that limit the depth of cut are the soil depth in the area and the slope. The depth of cut should not be too high as to expose the bed rock which makes the bench terraces unsuitable for cultivation. In higher slopes greater depth of cuts result in greater heights of embankments which may become unstable.

The width of the bench terraces (W) should be as per the requirement (purpose) for which the terraces are to be put after construction. Once the width of the terrace is decided, the depth of cut required can be calculated using the following formulae.

Case 1: When the terrace cuts are vertical

$$D = \frac{WS}{100} \quad (5.1)$$

S is the land slope in percent; $D/2$ is the depth of cut and W is the width of terrace.

Case 2: When the batter slope is 1:1

$$\frac{D/2}{W/2 + D/2} = \frac{S}{100}$$

$$D = \frac{WS}{(100 - S)} \quad (5.2)$$

Case 3: When the batter slope is $1/2:1$

$$\frac{D/2}{W/2 + D/4} = \frac{S}{100}$$

$$D = \frac{2WS}{(200 - S)} \quad (5.3)$$

After deciding the required width, the depth of cut can be calculated from one of the above formulae.

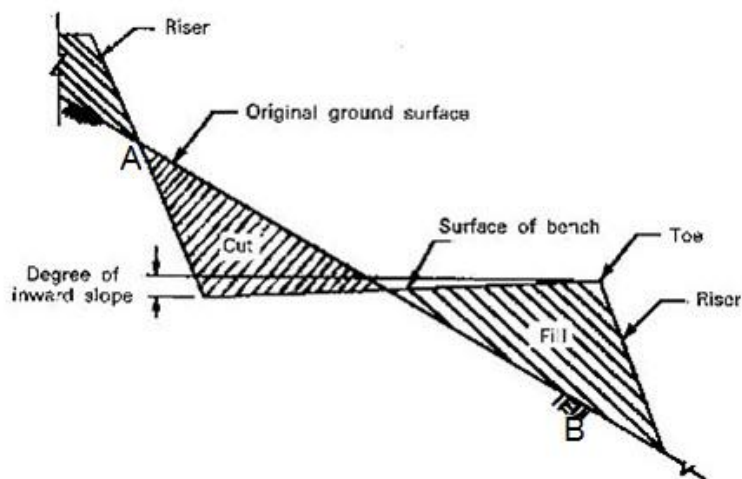

Fig: 5.3 Cross section of bench terraces.

The design of the terrace cross section consists of deciding (1) the batter slope, (2) dimensions of the shoulder bund, (3) inward slope of the terrace and the dimensions of the drainage channel in case of terraces sloping inward, and (4) outward slope in case of terraces sloping outward (Fig. 5.3). The batter slope is mainly for the stability of the fill or the embankment. The flatter the batter slope, the larger the area lost due to bench terracing. Vertical cuts are to be used in very stable soils and when the depth of the cut is small (up to 1 m). Batter slopes of $\frac{1}{2}: 1$ can be used in loose and unstable soils. The size of the shoulder bunds in case of terraces sloping inward is nominal. In case of terraces with flat top and sloping outwards, larger sections of shoulder bunds are required as water stands against these bunds. The bund cross section depends upon the terrace width and soil conditions. The inward slope of the terrace may be from 1 in 50 to 1 in 10 depending upon the soil conditions. For these terraces a drainage channel is to be provided at the inner edge of the terrace to dispose of the runoff.

5.5 Alignment of Bench Terraces

Alignment of bench terraces should start from the ridge and progress towards the valley. The average land slope of the area to be terraced should be determined by taking levels and then the specifications of the terrace should be worked out. Contour lines may be marked with the help of a leveling instrument. Taking a contour line as the centre line, the terrace width may be marked on the ground. The alignment may now be examined and suitable adjustments should be made wherever necessary taking into considerations the local conditions like depressions, sharp turns, field boundaries etc. that exist at the site.

Construction of the bench terraces may be started from the highest terrace and proceeded downwards. By this method, the top soil and the subsoil get mixed up and the top soil may not be available for the terrace surface. In cases where the subsoil condition is not good, it is necessary to keep the top soil apart and again spread it on the terrace. This can be accomplished by starting the construction of the terraces from the lower most one. After the construction of the first terrace, the top soil from the second terrace may be spread on the first terrace and the process continued for subsequent terraces. In bench terraced areas, suitable outlets should be provided to dispose of the runoff safely. In most of the cases one of the sides of the hill slope where vegetation is well established can be used as the outlet. Where such outlets are not available or feasible, waterways are to be formed to dispose of the runoff.

5.6 Area Lost for Cultivation due to Bench Terracing

The area lost for cultivation due to bench terracing of a slope can be calculated as follows.

Consider a batter slope of 1:1. Let D be the vertical interval of the benches to be laid out on a land with a slope of $S\%$, along AB in Fig. 5.3 and the batter of the risers is 1:1. L is the horizontal interval between the benches i.e., projected length of AB on horizontal plane. Actual distance of AB is given by:

$$\begin{aligned} AB &= \sqrt{L^2 + D^2} \\ &= L \left[1 + \frac{D^2}{2L^2} + \frac{D^4}{8L^4} + \dots \right] \end{aligned} \quad (5.4)$$

$$\begin{aligned} AB &= L + \frac{D^2}{2L} \\ L &= \frac{100D}{S} \\ AB &= \frac{100D}{S} + \frac{D^2}{2} \cdot \frac{S}{100D} \\ &= \frac{100D}{S} + \frac{DS}{200} \end{aligned} \quad (5.5)$$

If W is the width available for cultivation after terracing:

$$\begin{aligned} W + D &= L = \frac{100D}{S} \\ W &= \frac{100D}{S} - D = \frac{100D - DS}{S} \end{aligned} \quad (5.6)$$

Width not available for cultivation after terracing (from equations 5.5 and 5.6)

$$\begin{aligned} &= AB - W \\ &= \frac{100D}{S} + \frac{DS}{200} - \frac{100D}{S} + \frac{DS}{S} \\ &= \frac{DS}{200} + \frac{DS}{S} \end{aligned}$$

Width loss in percentage of original inclined width AB

$$= \frac{\frac{DS}{200} + \frac{DS}{S}}{\frac{100D}{S} + \frac{DS}{200}} * 100$$

$$= \frac{\frac{S}{200} + 1}{\frac{100}{s} + \frac{S}{200}} * 100 = \frac{(S+200)S}{20000 + S^2} * 100$$

By dividing the numerator and the denominator by 100 width lost in percentage of the original width

$$= \frac{S+200}{\frac{200}{S} + \frac{S}{100}}$$

The percentage width lost can be taken as the percentage area lost. When the batter is vertical, the length of bench terrace per hectare in metres will be $10000/W$ where W is in metres. When the batter slope is 1:1 the length per hectare in metres will be $10000/W + D$; D and W being in meters.

5.7 Maintenance of Bench Terraces

New terraces should be protected at their risers and outlets and should be carefully maintained, especially during the first two years. After cutting a terrace, its riser should be shaped and planted with grass as soon as possible. Sod-forming or rhizome-type grasses are better than those of the tall or bunch-type. Although tall grasses may produce considerable forage for cattle, they require frequent cutting and attention. The rhizome-type of local grass has proved very successful in protecting risers. Stones, when available, can also be used to protect and support the risers. An additional protection method is hydro-seeding. The outlet for drainage-type terraces is the point where the run-off leaves the terrace and goes into the waterway. Its gradient is usually steep and should be protected by sods of earth. A piece of rock, a brick, or a cement block, is sometimes needed to check the water flow on steeper channels. Similar checks on water flow are required for level bench terraces where the water falls from the higher terraces onto those below. A piece of rock should be placed on the lower terrace to dissipate the energy of the flowing water. The shoulder bund should be planted with permanent vegetation and ploughing of the toe of bund should be avoided. The batter slope of the terraces should be stabilized and protected by establishing deep rooted and soil binding spreading type of grasses.

5.7.1 Benches

The toe drains should be always open and properly graded; water must not be allowed to accumulate in any part of the terrace. All runoff should be allowed to collect at the toe drains for safe disposal to the protected waterway. Obstacles such as continuous mounds or beds must be removed at regular intervals to allow water to pass to the toe drain. Grasses and

weeds should be removed from the benches. Correct gradients should be maintained and reshaped immediately after crops are harvested. Ploughing must be carried out with care so as not to destroy the toe drains and the grade.

5.7.2 Risers

Grasses should be grown well on the risers. Weeds and vines which threaten the survival of the grasses should be cut down or uprooted. Grasses should not be allowed to grow too high. Any small break or fall from the riser must be repaired immediately. Cattle should not be allowed to trample on the risers or graze the grasses. Runoff should not be allowed to flow over the risers on reverse-sloped terraces.

5.7.3 Outlets for Drainage Types of Terrace

The outlets should be checked to see whether they are adequately protected. Make sure that the water flows through the outlets instead of going around them. Any breaks must be mended immediately.

5.7.4 Soil Productivity

Deep ploughing, ripping or sub-soiling is needed to improve the structure of the soils on the cut part of the bench terraces. Green manuring, compost or sludge is needed in the initial period in order to increase soil fertility. Soil productivity should be maintained by means of proper crop rotation and the use of fertilizers.

5.8 Solved Example of Terrace Design

On a 20% hill slope, it is proposed to construct bench terraces. If the vertical interval of terrace is 2 m, calculate (i) length of terrace per hectare, (ii) earth work required per hectare, and (iii) area lost per hectare both for vertical cut and batter slope of 1:1. The cut should be equal to fill.

Solution

Using the equation for vertical cut, and estimating the width of bench terrace (W)-

$$W = \frac{100D}{S} = \frac{100 \times 2}{20} = 10 \text{ m}$$

$$\text{Length of terrace per hectare} = \frac{10000}{10} = 1000 \text{ m}$$

$$\text{Earthwork} = \frac{1}{2} \times 5 \times \frac{2}{2} \times 1000 = 2500 \text{ m}^3.$$

$$\text{Area lost} = \frac{\sqrt{D^2 + W^2} - W}{\sqrt{D^2 + W^2}} \times 100 \text{ nearly } 2\%$$

When the batter slope is 1:1, using equation

$$\begin{aligned} W &= \frac{D(100 - S)}{S} \\ &= \frac{2(100 - 20)}{20} \\ &= 8 \text{ m} \end{aligned}$$

$$\begin{aligned} \text{Length per hectare} &= \frac{10000}{8 + 1 + 1} \\ &= 1000 \text{ m} \end{aligned}$$

$$\begin{aligned} \text{Earthwork per hectare} &= 0.5(5 \times 1 - 1 \times 1) \times 1000 \\ &= 2000 \text{ m}^3. \end{aligned}$$

Area lost for cultivation using equation

$$= \frac{\frac{S + 200}{\frac{200}{S} + \frac{S}{100}}}{\frac{20 + 200}{\frac{200}{20} + \frac{20}{200}}} = 21.57\%$$

Lesson 6 Bunding Methods for Water Erosion Control

Bunding is a mechanical method for control of soil erosion. When agronomical measures alone are not sufficient, such and other mechanical measures should be adopted.

6.1 Mechanical Measures for Water Erosion Control

Mechanical practices are engineering measures used to control erosion from slopping land surfaces and thus land surface modification is done for retention and safe disposal of runoff water. In the design of such practices, the basic approach is (i) to increase the time of stay of runoff water in order to increase the infiltration time for water, (ii) to decrease the effect of land slope on runoff velocity by intercepting the slope at several points so that the velocity is less than the critical velocity, and (iii) to protect the soil from erosion caused by the runoff water. The mechanical measures adopted for soil and water conservation are: bunding, terracing etc.

6.2 Bunds (Contour Bunds, Graded Bunds) and their Design

Bund is an engineering measure of soil conservation, used for creating obstruction across the path of surface runoff to reduce the velocity of flowing water. It retains the running off water in the watershed and thus to helps to control soil erosion. Bunds are simply embankment like structures, constructed across the land slope. Different types of bunds are used for erosion control and moisture conservation in the watersheds. When the bunds are constructed along the contours with some minor deviation to adapt to practical situation, they are known as **contour bunds**. If the bunds are constructed with some slope, they are known as **graded bunds**. No farming is done on bunds expects at some places, where some types of stabilization grasses are planted to protect the bund. The choice of the types of bund is dependent on land slope, rainfall, soil type and the purpose of the bund in the area. The contour bunds are recommended for areas with low annual rainfall (< 600 mm) agricultural fields with permeable soils and having a land slope of less than 6%, while graded bunds are used for safe disposal of excess runoff in areas with high rainfall and relatively impervious soil.

In India, contour and graded bunding have been practiced for a long time and the Indian farmers have very good knowledge about it. From the experience, it has been found that bunds could stand well in shallow, medium and medium deep soils. In deep black soil, due to cracks in dry condition, the bunds fail. Through these cracks, water continues to flow and big breaches are usually created. This results in severe damage to the fields. Although various erosion problems exist in black cotton soils, contour bunding cannot be taken up in such soils successfully.

6.2.1 Contour Bunds

Contour bunds are laid out in those areas which have less rainfall and permeable soils. The major requirements in such areas are prevention of soil erosion and conservation of rain water in the soil for crop use. To maximize the conservation of rainwater in the soil, no longitudinal slope is provided to the field strip. In such a system of bunding, the bunds are designed to be laid out on contours with minor adjustments, wherever necessary.

The main functions of contour bunds are:

1. It reduces the length of slope which in turn reduces the soil erosion.
2. The water is impounded for some time and gets recharged into the soil which helps in crop cultivation.

The limitations of contour bunds are:

1. The contour bunds are suitable for those areas, which receive the annual rainfall less than 600 mm
2. It is not suitable for clayey soils
3. Contour bunding is not suitable on the land slopes greater than 6%.

6.2.2 Graded Bunds

Graded bunds are laid out in areas where the land is susceptible to water erosion, the soil is less permeable and the area has water logging problems. A graded bund system is designed to dispose of excess runoff safely from agricultural fields. A graded bund is laid out with a longitudinal slope gradient leading to outlet. The gradient can be either uniform or variable. The uniformly-graded bunds are suitable for areas where the bunds need shorter lengths and the runoff is low. The variable-graded bunds are required where bunds need longer lengths, owing to which the cumulative runoff increases towards the outlets. In these types of bunds, variations in the grade are provided at different sections of the bund to keep the runoff velocity within the desired limits so as not to cause any soil erosion.

The limitations of the system are:

- Due to crossing of farm implements, the bunds are disturbed and some soil is lost.
- Proper maintenance is required at regular interval.

6.3 Design Specification of Bunds

The following parameters should be considered for bund design:

- 1. Type of Bund:** The type of bund (contour or graded bund) to be constructed depends upon the rainfall and soil condition. Contour bunds are preferred for construction in areas receiving annual rainfall less than 600 mm and where soil moisture is a limiting factor for crop production. Graded bunds are recommended in heavy and medium rainfall areas. The grade to be provided to the bund may vary from 0.2% to 0.3%.
- 2. Spacing of the Bunds:** The basic principles to be adopted for deciding the spacing of bunds are: (1) the seepage zone below the upper bund should meet the saturation zone of the lower bund; (2) the bunds should check the water at a point where the water attains erosive velocity and (3) the bund should not cause inconvenience to the agricultural operations.

For determining the spacing of the bunds the following formula is used:

$$V.I. = \frac{S}{a} + b \quad (6.1)$$

where,

V.I. = vertical interval between consecutive bunds,

S = land slope (percent) and

a and b = constants, depend upon the soil and rainfall characteristics of the area.

The above equation is area specific. It can be modified for areas with different rainfall amounts.

1. For the areas of heavy rainfall:

$$V.I. = 10S + 60 \quad (6.2)$$

2. For the areas having low rainfall

$$V.I. = 15S + 60 \quad (6.3)$$

In which, VI is in cm and S is in percent.

The bund spacing can not be easily located on the ground on the basis of vertical interval. But the horizontal interval (spacing) can be easily measured on the land surface. For this purpose, the relationship between horizontal and vertical spacing is important and is given below.

$$H.I. = V.I. / S$$

Here, H.I. indicates the horizontal distance of the bund and V.I. is the vertical interval.

3. Size of the Bund: The size of bund includes its height, top width, side slopes and bottom width. The height of bunds mainly depends upon the slope of the land, spacing of the bunds and the maximum intensity of rainfall expected in the area. Once the height of the bund is determined, other dimensions of the bund viz., base width, top width and side slopes are determined using the information on the nature of the soil. Depending on the amount of water to be intercepted, the height of the bund can be calculated as given below (Fig. 6.1).

Let X = height of the bund, L = distance between bunds, V = vertical interval between bunds, and W = width of water spread.

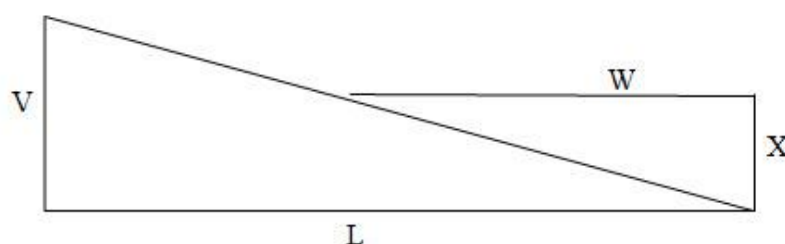

Fig. 6.1. Basic diagram for deriving the height of bund.

$$\frac{W}{L} = \frac{X}{V} \text{ or } W = \frac{LX}{V} \quad (6.4)$$

Considering 1m length of the bund, amount of water stored = $\frac{1}{2} WX$

Substituting for W from Eqn. 6.4, amount of water stored

$$= 0.5 \left(\frac{LX^2}{V} \right) \quad (6.5)$$

Assuming that any time the maximum rainfall, which the bunds have to withstand, is 15 cm high; water retained by 1 m length of the bund

$$= \frac{15}{100} (L.1) = \frac{3L}{20} \quad (6.6)$$

Now equating both these values:

$$0.5 \left(\frac{LX^2}{V} \right) = \frac{3L}{20}$$

$$\text{Height of the bund, } X = \sqrt{\frac{3V}{10}} \quad (6.7)$$

When, the land slope is expressed as S per cent.

$$V = LS/100$$

$$x = \sqrt{\frac{3LS}{1000}} \quad (6.8)$$

L and X are in meters and S is the per cent slope. This is the theoretical height and suitable free board is added to arrive at the practical height of the bund.

Base width of the bund depends upon the hydraulic gradient of water in the soil. Side slopes are dependent upon the angle of repose of the soil. A general value of the hydraulic gradient assumed is 1:4. Side slopes of the bund recommended for different soils are given in Table 6.1.

Table 6.1. Side slopes of the bunds recommended for different soil types

Side slopes	1.5 to 1	2 to 1	2.5 to 1
Soil types	Red Gravel	Light Sandy loam	Sand
	Light red loam	Clay	
	Black loam	Black cotton soil	
	White gravel	Soft decomposed rock	

Some of the typical cross sections of bunds are shown in Table 6.2. Usually a higher size of the bunds than required by the hydraulic considerations is adopted to allow for the settlement and poor maintenance by the cultivators.

Table 6.2. Typical bund cross-sections for scarcity areas

Soil Types	Top width (m)	Bottom width (m)	Height(m)	Side Slope
Full maximum or soil layer up to 7.5 cm	0.45	1.95	0.75	1:1
Soil layer from 7.5 cm to 23 cm	0.45	2.55	0.83	1.25 :1
Full soil or soil layer from 23 cm to 45 cm	0.53	3.0	0.83	1.50: 1
Full soil 45 cm to 80 cm	0.60	4.2	0.90	2:1

4. Length of Bund. The length of bund is determined by calculating the horizontal interval of the bund formed. The length of bund per hectare area of land is given as:

$$L = 10000/H.I$$

$$= (10000*S)/(VI*100)$$

$$= 100(S/VI) \quad (6.9)$$

5. Earth Work: The earth work of bunding system includes the sum of earthwork made in main bunds, side bunds and lateral bunds formed in the field. The earthwork of any bund is obtained by multiplying the cross-sectional area to its total length. The total earthwork can be given by the following equation.

$$E_t = E_m + E_s + E_l \quad (6.10)$$

where, E_t = total earthwork, E_m = earthwork of main bunds, E_s = earthwork of side bunds, E_l = earthwork of lateral bunds, $E_m = \text{cross-sectional area} * \text{total length of bund} = (100S/VI) * \text{cross-sectional area}$.

Therefore, $E_s + E_l = ((100S/VI) * 30/100) * \text{cross-sectional area}$

Therefore, total $E_t = E_m + E_s + E_l$

$$= (100S/VI + 30S/VI) * \text{cross-sectional area}$$

$$= 130S/VI * \text{cross-sectional area}$$

$E_t = 1.3 * (100S/VI) * \text{cross-sectional area of bund}$

In the above calculation the value of $E_s + E_l$ is taken as 30% earth work of main contour bund (E_m) by assuming that the length of side and lateral bund to be as 30% of the length of main bund and their cross-sectional area is also equal to main bund.

6. Area Lost due to Bunding: It is calculated by multiplying the length of contour bund per hectare with its base width. i.e

$$A_L = 10000/HI * b$$

$$= 100S/VI * b$$

Where, b is the base width of bund.

This equation computes only the area lost due to main contour bund and not the area lost due to side and lateral bunds. Usually, the area lost due to side and lateral bunds is taken as 30% of the area lost due to main contour bund. Thus, the total area lost due to contour bunding is:

$$\left(\left(\frac{100S}{VI} \right) * b + \left(\frac{100S}{VI} \right) * b * \frac{30}{100} \right)$$

$$= 1.3 * \frac{100S}{VI} * b$$

The above equation can also be written in the following form to compute the area lost in percentage due to bunding:

$$A_L (\%) = 1.3 * S * b / VI$$

6.4 Construction of Bunds

Construction of bunds should start from the ridge and continue down the valley. This will ensure protection of the bunds if rains occur during construction. The base width area of the bund should be cleared of vegetation and the soil in this area should also be slightly distributed so that good binding can be achieved when the bund is formed over it. The burrow pits for the soil are generally located on the upstream side of the bund. It should have a uniform depth of 30 cm and the width can be varied as per necessity. The burrow pits should be continuous and no breaks are to be left. The burrow pits should not be located in a gully or depression. When the soil is dug, the clods should not be put on the bund at a time.

The earth should be put in layers of 15 cm and consolidated by trampling. The templates of the specified dimensions are used for checking the bund section. The bund section should be finally shaped, trimmed and slightly rammed on the top and the sides. After the bund formation, it is desirable to plough the field and the burrow pit.



AGRIMOON.COM

All About Agriculture...

Lesson 7 Gully Erosion

Gully erosion is an advance stage of rill erosion as rill erosion is the advanced stage of sheet erosion. It is the most spectacular form of erosion. Any concentration of surface runoff is a potential source of gully erosion. The Soil Conservation Society of America defines a gully as “a channel or miniature valley cut by concentrated runoff but through which water commonly flows only during and immediately after heavy rains. It may be dendritic or branching or it may be linear, rather long, narrow and of uniform width”. In India, the rate of soil erosion from gullies is 33 t/ha/yr in ravine regions (Shekinah and Saraswathy, 2005). The distinction between ravine, gully and rills is that of size. A gully is too large to be filled by normal tillage practices. A ravine is a deep narrow gorge. It is larger than a gully and is usually worn down by running water. It is estimated that about 4 million ha of land in India are affected by gully erosion (Michael and Ojha, 2012).

7.1 Development of Gullies

The main processes in the development of gullies are waterfall erosion and channel erosion. These two erosions are commonly found in the same gully. The extension of the gully head is usually by waterfall erosion; while the scouring of bottom and sides which enlarges the depth and width of gullies is by channel erosion. Gullies usually start with channel erosion. When an overfall develops at the head of the gully, the gully continues to develop by waterfall erosion. The waterfall erosion at gully head and advancement of the gully towards the upper edge of the watershed is shown in Fig. 7.1.

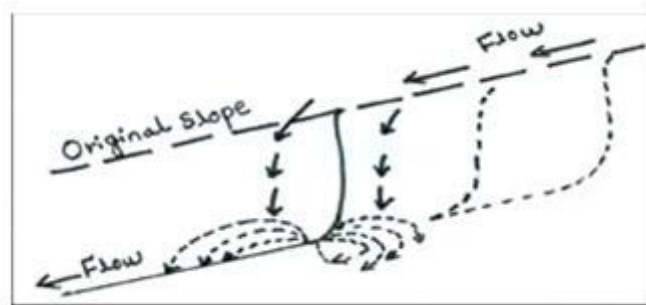

Fig. 7.1. Waterfall erosion at gully head.

The gully development is recognized in four stages:

Formation Stage: Scouring of top soil in the direction of general slope occurs as the runoff water concentrates. It normally proceeds slowly where the top soil is fairly resistant to erosion.

Development Stage: Causes upstream movement of the gully head and enlargement of the gully in width and depth. The gully cuts to the C-horizon of soil, and the parent materials are removed rapidly as water flows.

Healing Stage: Vegetation starts growing in the gully.

Stabilization Stage: Gully reaches a stable gradient, gully walls attain a stable slope and sufficient vegetation cover develops over the gully surface to anchor the soil and permit development of new topsoil.

7.2 Classification of Gullies

Gullies can be classified based on three factors viz. their size, shape (cross section) and formation of branches or continuation. The detailed classification is discussed below.

7.2.1 Based on Size (depth and drainage area)

Gully classification based on the size is presented in Table 7.1.

Table 7.1. Gully classification based on size

Classification	Depth (m)	Drainage area (ha)
Small	< 1	< 2
Medium	1 to 5	2 to 20
Large	> 5	> 20

7.2.2 Based on Shape

The classification of gullies based on shape is shown in Fig 7.2.

U-Shaped: These are formed where both the topsoil and subsoil have the same resistance against erosion. Because the subsoil is eroded as easily as the topsoil, nearly vertical walls are developed on each side of the gully.

V-Shaped: These gullies develop where the subsoil has more resistance than topsoil against erosion. This is the most common form of gully.

Trapezoidal: These gullies are formed where the gully bottom is made of more resistant material than the topsoil. Below the bottom of gully, the subsoil layer has much more resistance to get eroded and thus the development of further depth of gully is restricted.

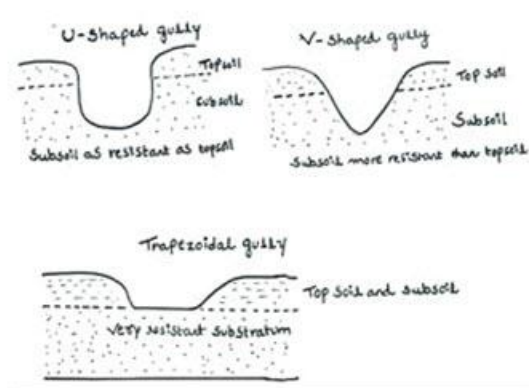

Fig. 7.2. Gully classes based on the shape of gully cross-section.

7.2.3 Based on the Formation of Branches or Continuation

Continuous Gullies: These gullies consist of many branches. A continuous gully has a main gully channel and many mature or immature branch gullies. A gully network is made up of many continuous gullies. A multiple-gully system may be composed of several gully networks.

Discontinuous Gullies: These may develop on hillsides after landslides. They are also called independent gullies. At the beginning of its development, a discontinuous gully does not have a distinct junction with the main gully or stream channel. Flowing water in a discontinuous gully spreads over a nearly flat area. After some time, it reaches the main gully channel or stream. Independent gullies may be scattered between the branches of a continuous gully, or they may occupy a whole area without there being any continuous gullies.

7.3 Principles of Gully Control

Generally, gullies are formed by an increase in surface runoff. Therefore, minimizing surface runoff is essential in gully control. The rate of gully erosion depends primarily on the runoff producing characteristics of the watershed, the watershed area, soil characteristics, size-shape and slope of gully etc. Watersheds deteriorate because of misuse of the land (man made changes), short intensive rainstorms, prolonged rains of moderate intensity, and rapid snow melts. The precipitation factors which turn into high runoff, develop flooding and form gullies. In gully control, the following three methods should be applied according to the order given:

- Improvement of gully catchments to reduce and regulate the runoff rates (peak flows).
- Diversion of surface water above the gully area.
- Stabilization of gullies by structural measures and accompanying re-vegetation.

When the first and/or second methods are applied in some regions of the countries with temperate climates, small or incipient gullies may be stabilized without having to use the third method. On the other hand, in tropical and subtropical countries which have heavy rains (monsoons, typhoons, tropical cyclones, etc.); all three methods have to be applied for successful gully control.

7.4 Gully Control Measures

Preventing the formation of gully is much easier than controlling it once it has formed. One of the major steps in a gully control programme is to plan the control of runoff from the drainage area. The various methods employed for controlling runoff may be considered in the following order:

- **Retention of Runoff on the Drainage Area:** It is possible through good crop management and applicable conservation practices such as contouring, strip cropping, bunding, terracing etc. Where contour bunds are used, runoff is greatly reduced. On cultivated areas, small and medium sized gullies can also be reclaimed by placing a series of earthfills across the gully.

- **Diversion of Runoff Around the Gullied Area:** The most effective control of gullies is by complete elimination of runoff from the gullied area. This can be obtained by diverting runoff from the gully, causing it to flow at a non- erosive velocity to a suitable outlet. Terraces and diversion ditches are generally used for diverting runoff from its natural outlet. Terraces are very effective in the control of small gullies on cultivated fields or even medium size shallow gullies. If the slope above a gully is too steep for terracing, or if the drainage area is pasture or woodland, diversion ditches may be used to keep the runoff out of the gully.
- **Conveyance of Runoff through the Gully:** If it is not possible to either retain or divert the runoff, then runoff must be conveyed through the gully itself. This is possible only if vegetation can be established in the gullies, or if soil conservation structures are built at critical points to give primary control.

7.5 Classification of Gully Control Measures or Structures

Basically gully control structures are used to reduce soil erosion, control sedimentation, and harvesting water. Gully control measures are mainly of two types.

7.5.1 Biological or Vegetative Measures

7.5.1.1 Anti-Erosion Crops

These crops stabilize gully. Crops produced provide supplementary income.

7.5.1.2 Changing Gully into Grassed Waterway

Small and medium size gullies can be converted into grassed waterways. In practice, gully is shaped and suitable species of grasses are grown. Channel cross-section should be broad and flat, to keep water spread uniform over a wide area.

7.5.1.3 Sod Flumes

It may be successfully used to control overfall in gullies with head < 3 m and area <10 ha. The design of sod flume is shown in Fig 7.3. It serves the purpose of preventing further waterfall erosion by providing a protected surface over which the runoff may flow into the gully. Slope varies with the soil type, size of watershed, height of overfall and type of sod used. 4:1 is the steepest slope considered for its design. To maintain a non-erosive velocity, flume should be wide enough. The maximum depth of flow over the flume should not exceed 30 cm.

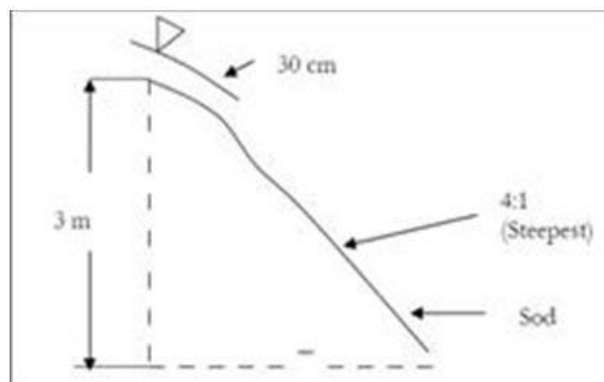

Fig. 7.3. Sod flume.

7.5.1.4 Sod Strip Checks

These checks are best adapted to small gullies with small to medium sized watersheds. These checks cannot be used in gullies with very steep grades. Strips are laid across gully channel (Fig. 7.4). Strips should have a minimum width of 30 cm and should extend up to gully sides at least 15 cm. Strip spacing usually varies from 1.5 to 2.0 m.

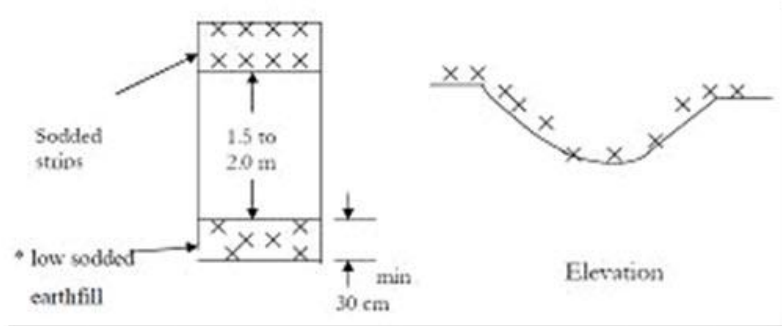

Fig. 7.4A. Sod strip checks.



Fig. 7.4B. A series of sod-strip checks in a small gully. (Source: Agr. Handbook No. 61. USDA, SCS).

7.5.1.5 Low Sodded Earthfills

These are used as substitutes for temporary gully controlled structures in small and medium sized gullies. Already growing sods are cut along with soil mass and combined together to form earth fill dams (Fig. 7.5). They are constructed with a maximum height of 45 cm, upstream (u/s) side slope of 3:1 and downstream (d/s) side slope of 4:1.

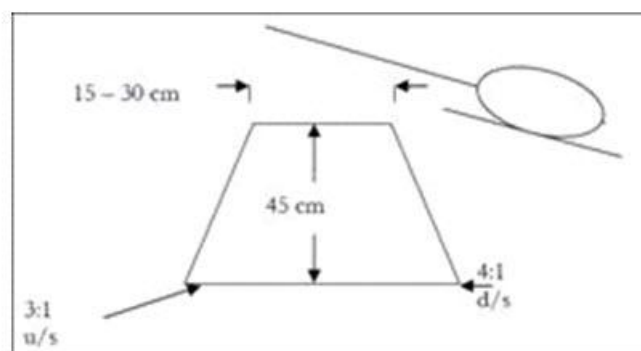

Fig. 7.5 Low sodded earthfills.

7.5.1.6 Trees, Shrubs etc.

Trees, shrubs etc. are used to stabilize severely eroded gullied area. Generally gullied area is fenced and trees are grown. A plant spacing of 1×1 m, 1.2×1.2 m or a maximum of 2×2 m should be maintained.

7.5.2 Engineering Measures (Temporary and Permanent)

7.5.2.1 Temporary Gully Control Structures (TGCS)

TGCS have a life span of 3 to 8 years and they are pretty effective where the amount of runoff is not too large. These are made of locally available materials. Basic purposes they serve are to retain more water as well as soil for proper plant growth and prevent channel erosion until sufficient vegetation is established on the upstream side of the gully. TGCS are of many types:

- Woven wire check dams
- Brush dams
- Loose rock dams
- Plan or slab dams
- Log check dams
- Boulder check dams

7.5.2.2 Permanent Gully Control Structures (PGCS)

If the erosion control programmer requires bigger structure, then PGCS are used. They include:

- Drop spillway
- Drop-inlet spillway
- Chute spillway
- Permanent earthen check dams

7.6 Design Criteria of TGCS

- The overall height of a temporary check shouldn't ordinarily be more than 75 cm. An effective height of about 30 cm is usually considered sufficient. Also, sufficient freeboard is necessary.
- Life of the check dams under ordinary conditions should be in between 3 to 8 years.
- Spillway capacity of check dams is generally designed to handle peak runoff that may be expected once in 5 to 10 year return period.
- Since the purpose of check dams in gully control is to eliminate grade in the channel, check dams theoretically should be spaced in such a way that the crest elevation of one will be same as the bottom elevation of the adjacent dam up-stream.

- As an integral part of most of the checks dams, an apron or platform of sufficient length and width must be provided at the down-stream end to catch the water falling over the top and to conduct it safely without scouring.

7.6.1 Woven Wire Check Dams

Woven-wire check dams are small barriers which are usually constructed to hold fine material in the gully (Fig. 7.6).

General:

- Used in gullies of moderate slopes (not more than 10 percent) and small drainage areas that do not have flood flows which carry rocks and boulders.
- Help in the establishment of vegetation for permanent control of erosion.
- Dam is built in half-moon shape with the open end up-stream.
- The amount of curvature is arbitrary: but an off-set equal to $1/6^{\text{th}}$ of the width of gully at the dam site is optimum.

Construction:

- To construct a woven-wire dam, a row of posts is set along the curve of the proposed dam at about 1.2 m intervals and 60-90 cm deep.
- Heavy gauge woven wire is placed against the post with the lower part set in a trench (15-20 cm deep), and 25-30 cm projected above the ground surface along the spillway width.
- Rock, brush or sod may be placed approximately up to a length of 1.2 m to form the apron.
- For sealing the structure, straw, fine brush or similar material should be placed against the wire on the upstream side upto the height of spillway.

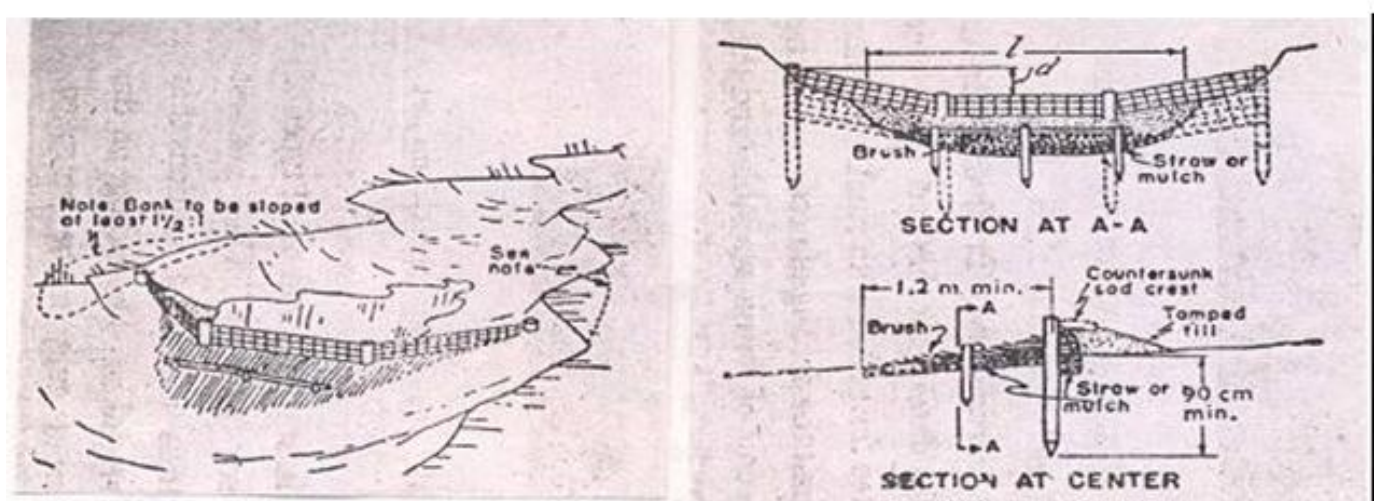

Fig. 7.6. Woven wire check dams. (Source: Agr. Handbook No. 61. USDA, SCS).

7.6.2 Brush Dams

General:

- Cheap and easy to build, but least stable of all types of check dams.
- Best suited for gullies with small drainage area.
- Center of the dam is kept lower than the ends to allow water to flow over the dam rather than around it (Fig. 7.7).

Construction:

- For a distance of 3-4.5 m along the site of the structure, sides and bottom of the gully are covered with thin layer of straw or similar fine mulch.
- Brushes are then packed closely together over the mulch to about one half of the proposed height of dam.
- Several rows of stakes are then driven crosswise in the gully, with rows 60 cm apart, and stakes 30-60 cm apart in the rows.
- Heavy galvanized wire is used to fasten the stakes in a row, as well as to firmly compress the brushes in places.
- Sometimes large stones are also placed on top of brush to keep it compressed and in close contact with the bottom of the gully.
- Major weakness is the difficulty of preventing the leaks and constant attention is required to plug openings of appropriate size with straw as they develop.

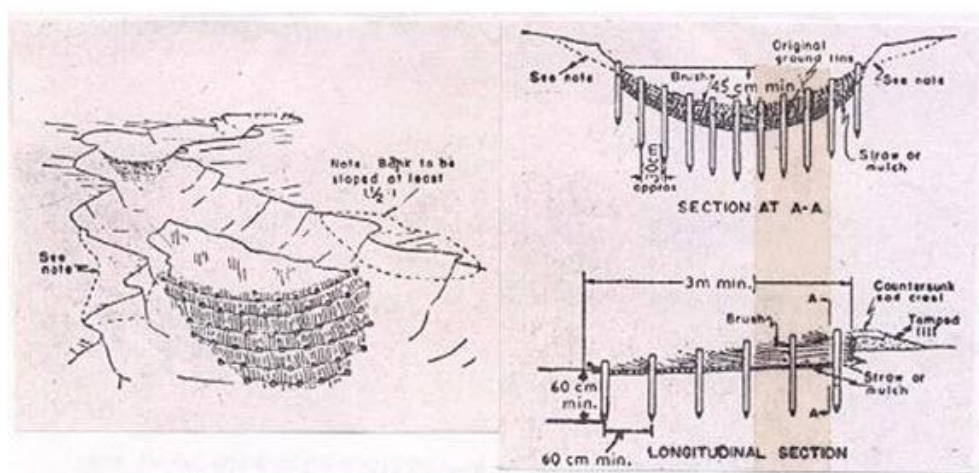

Fig. 7.7. Brush dam. (Source: Agr. Handbook No. 61. USDA, SCS).

7.6.3 Loose Rock Dams

Loose rock dams made of relatively small rocks are placed across the gully (Fig. 7.8). The main objectives for these dams are to control channel erosion along the gully bed, and to stop waterfall erosion by stabilizing gully heads. Loose stone check dams are used to stabilize the incipient and small gullies and the branch gullies of a continuous gully or gully

network. The length of the gully channel is not more than 100 m and the gully catchment area is 2 ha or less. These dams can be used in all regions.

General:

- Suitable for gullies with small to medium size drainage area.
- Used in areas where stones or rocks of appreciable size and suitable quality are available.
- Flat stones are the best choice for dam making.
- Stones can be laid in such a way that the entire structure is keyed together.
- If round or irregular shaped stones are used, structure is generally encased in woven-wire so as to prevent outside stones from being washed away.
- If the rocks are small, they should be enclosed in a cage of woven-wire.

Construction:

- A trench is made across the gully to a depth of about 30 cm. This forms the base of the dam on which the stones are laid in rows and are brought to the required height.
- The center of the dam is kept lower than the sides to form spillway.
- To serve as an apron, several large flat rocks may be countersunk below the spillway, extending about 1 m down-stream from the base of the dam.

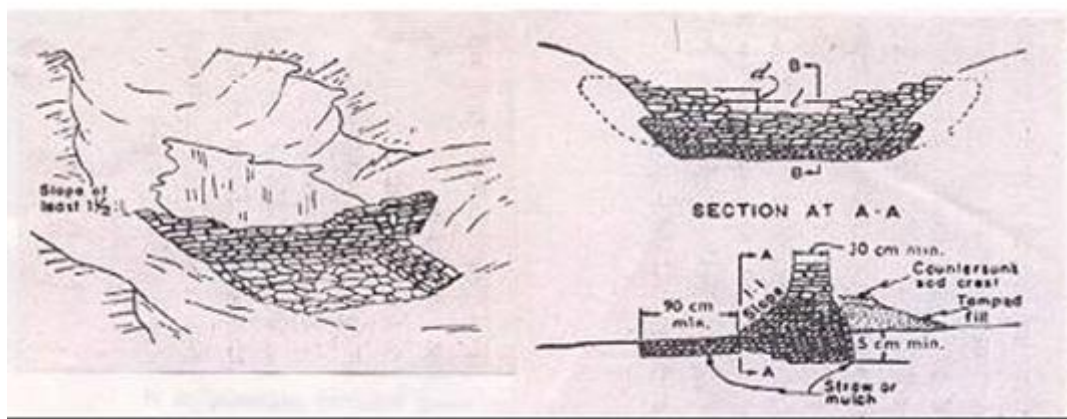

Fig. 7.8. Loose rock dam. (Source: Agr. Handbook No. 61. USDA, SCS).

7.6.4 Plank or Slab Dam

General:

- These dams are suitable in areas where timber is plentiful, and dam can be constructed with much less labor as compared to other types of temporary structures.
- These dams can generally be used in gullies with larger drainage area.

Construction:

- The planks are placed across the gully to form the dam. If the planks are not close fitting, straw or grass may be used for sealing purposes.
- A suitable opening for the spillway notch is made over the headwall. On the up-stream face, a well tempered earth fill is made.
- On the down-stream, the apron may be made of loose rock, brush, sod or planks.

7.6.5 Log Check Dam

They are similar to plank or slab dams. Logs and posts used for the construction are placed across the gully. They can also be built of planks, heavy boards, slabs, poles or old railroad ties. The main objectives of log check dams are to hold fine and coarse material carried by flowing water in the gully, and to stabilize gully heads. They are used to stabilize incipient, small and branch gullies generally not longer than 100 m and with catchment areas of less than two hectares. The maximum height of the dam is 1.5 m from the ground level. Both, its downstream and upstream face inclination are 25 percent backwards. The spillway is rectangular in shape. In general, the length and depth of spillway are one to two meters and 0.5 to 0.6 m respectively (Fig. 7.9).

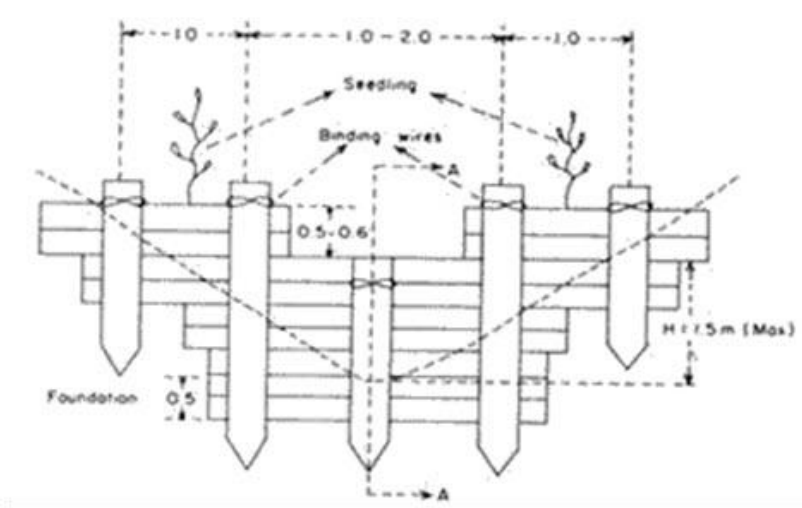

Fig. 7.9A. Front view of the first log check dam. (Source: Agr. Handbook No. 61. USDA, SCS).

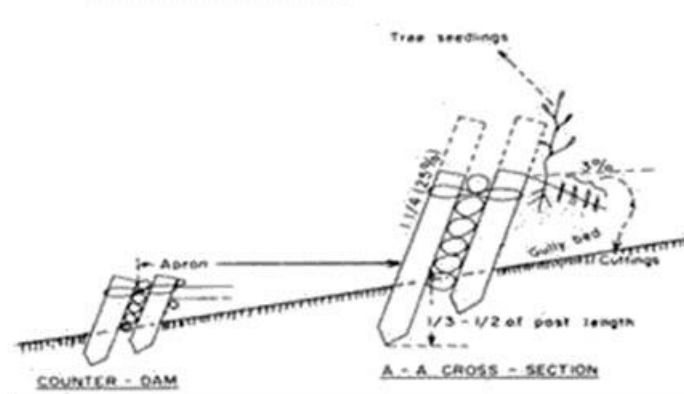

Fig. 7.9B. A-A cross-section of the first log check dam and counter dam. (Source: Agr. Handbook No. 61. USDA, SCS).

7.6.6 Boulder Check Dams

Boulder check dams placed across the gully are used mainly to control channel erosion and to stabilize gully heads. In a gully system or multiple-gully system all the main gully channels of continuous gullies (each continuous gully has a catchment area of 20 ha or less and its length is about 900 m) can be stabilized by boulder check dams. These dams can be used in all regions. The maximum total height of the dam is 2 m. Foundation depth must be at least half of the effective height. The thickness of the dam at spillway level is 0.7 to 1.0 m (average 0.85 m), and the inclination of its downstream face is 30 percent (1:0.3 ratio); the thickness of the base is calculated accordingly. The upstream face of the dam is usually vertical. If the above-mentioned dimensions are used, it is not necessary to test the stability of the dam against overturning, collapsing and sliding. The dimensions of the spillway (Fig. 7.10) should be computed according to the maximum discharge of the gully catchment area. The form of the spillway is generally trapezoidal.

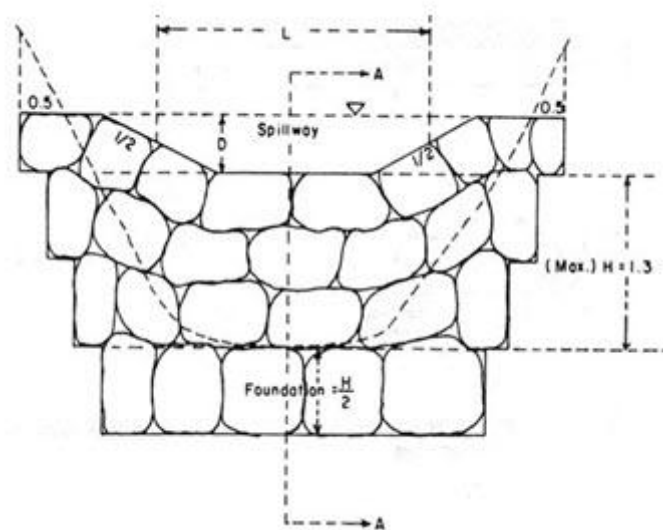

Fig. 7.10. Front view of the boulder check dam. (Source: Agr. Handbook No. 61. USDA, SCS).

Problem 7.1: Design the notch dimensions of a wooden slab dam to carry a peak flow of 0.6 m³/sec. The notch has rectangular opening. Width of gully channel is 2.5 m.

Solution

$$Q = 0.6 \text{ m}^3/\text{sec} = 600 \text{ litres/sec}$$

Length, L , of notch = width of gully channel

$$= 2.5 \text{ m} = 250 \text{ cm}$$

$$Q = 0.0171 LH^{3/2}$$

Substituting the values in the formula,

$$600 = 0.0171 \times 250 \times H^{3/2}$$

$$H = 27.01 \text{ cm, say } 27 \text{ cm}$$

Assume a freeboard of 5 cm

Total depth of notch = $27 + 5 = 32$ cm

The design dimensions of the notch are: length 2.5 m; total depth 32 cm.



AGRIMOON.COM

All About Agriculture...

Lesson 8 Drop Spillway

The drop structure is a weir structure, is limited to a maximum drop of 3 m and it is not a favorable structure where temporary spillway storage is desired to obtain a large reduction in the discharge at or d/s from the structure.

8.1 Permanent Gully Control Structures (PGCS)

PGCS, built of masonry, reinforced concrete or earth are efficient supplemental control measures in soil and water conservation. They are helpful in situation where vegetative measures or temporary structures fail to serve the purpose of controlling the concentration of runoff or reclaim a gully. PGCS are generally used in medium to large gullies with medium to large drainage area. PGCS are designed to handle runoff from the heaviest rains that may be expected once in 25 to 50 years or more depending upon the estimated life of the structure. Three basic permanent structures, generally employed in stabilizing gullies are:

1. Drop spillway
2. Drop inlet spillway
3. Chute spillway

8.2 Salient Features of PGCS

1. The main functions of PGCS are:

- a) To halt the advance of over-fall at gully head,
- b) To stabilize the grade so that a gully can be changed to vegetative waterway.

2. A gully control structure must not only have sufficient capacity to pass the design discharge, but the kinetic energy of discharge must also be dissipated within the confines of the structure in a manner and to a degree that will protect both the structure and the downstream channel from damage.

3. Two primary causes of failure of permanent structures are:

- a) Insufficient hydraulic capacity and
- b) Insufficient provision for energy dissipation.

8.3 Planning for Design

These structures must be designed after careful investigations of various factors influencing the characteristics of runoff approaching the structure (with reference to specific site conditions), the downstream flow characteristics and other specific requirements. There are

no standard solutions which can be applied to all the problems encountered in the field. The design should include analysis of all the factors affecting the work. Basic data needed are:

1. Topographic map of the contributing watershed and the adjoining downstream area,
2. Information on soil.
3. Information on rainfall.
4. Existing land use pattern.

Preliminary investigations consisting of:

1. Reconnaissance of area,
2. Collection and analysis of available data and
3. Outline survey are pre-requisites in the overall planning of a permanent structure.

This helps the designer to study alternative site locations and to establish the techno-economic feasibility of the project. In the absence of adequate data, a safe design requires conservative assumptions. However, every effort should be made to collect all the available data. The more dependable the data, the smaller is the margin of over design and more economical will be the resulting structure.

8.4 Design Procedure

The design procedure of a PGCS may be divided into three phases:

1. Hydrologic design
2. Hydraulic design
3. Structural design

8.4.1 Hydrologic Design

1. It involves the determination of the design runoff rates and volumes which the structure is expected to handle.
2. Prediction of design peak runoff rates and flood volumes includes the study of the factors influencing the runoff characteristics of rainfall and watershed.
3. It is designed to handle runoff from the heaviest rain expected once in 25 to 50 years or more, depending upon the estimated life of structure.
4. For the design of spillway for flood protection structures like drop inlet spillway information on total runoff volume, inflow-outflow, reservoir stage and storage characteristics are important.
5. Flood routing procedure is employed in designing the spillways of drop inlet structures.
6. The Rational method of predicting peak runoff rate can be employed for designing drop structures and chute spillways.

8.4.2 Hydraulic Design

1. It involves the study of the requirements of the dimensions of the structure, in order to handle the estimated peak runoff through drop and chute structures.
2. It also involves the study of the effects of flow on the upstream and downstream reaches of the channel and the dissipation of the kinetic energy produced by the drop in the water surface elevation.

8.4.3 Structural Design

1. It provides the required strength and stability to the component parts of the structure. It involves the analysis of the various forces acting on the structure. The forces are: These forces disturb the equilibrium of the structure and give rise to internal stress, which should be effectively resisted by the material with which the structure is constructed.
 - a. The water pressure (static and dynamic) which acts on the structure.
 - b. The forces developed due to the outflow over the structure.
 - c. The effect of water flow underneath the structure (seepage, sub-surface flow).
2. These forces disturb the equilibrium of the structure and give rise to internal stress, which should be effectively resisted by the material with which the structure is constructed.
3. The structure must be stable under the action of the external forces and be able to withstand the sliding forces resulting from its own weight.

8.5 Basic Components of PGCS

1. These components can be divided into three groups:
 - a) Inlet:** Water enters the structures through the inlet, which may be in the form of a box or weir in a wall.
 - b) Conduit:** The conduit receives the water from the inlet and conducts it through the structure. It restricts the water to a definite channel. The conduit may be closed in the form of a box channel or it may be open as in a rectangular channel.
 - c) Outlet:** Its function is to discharge the water into the channel below at a safe velocity. The outlet should provide for the dissipation of kinetic energy of the discharge within the confines of the structure.

8.6 Drop Spillway

It is a weir structure, in which flow passes through the weir opening, fall or drops on an approximately level apron or stilling basin and then passes into the downstream channel. Its use is limited to a maximum drop of 3 m. It is mainly used at the gully bed to create a control point. Several such drop structures are constructed across the gully width throughout the length at fixed intervals. The series of such structures, develop a continuous break to flow of water, causing deposition of sediments and thus filling the gully section. Sometimes, the drop structures are also used at the gully head to pass the flow safely and controlling the gully head. The different components of drop structures are shown Fig. 8.1.

8.6.1 Components and Functions

1. **Head wall:** It acts as a front wall against runoff flow in the drop spillway. It is constructed across the gully width. A notch of suitable size is also made at the top in the headwall for easy water conveyance. Rectangular notch is most commonly used. The size of the notch should be sufficient to allow the water very safely.
2. **Head Wall Extension:** It is the extended portion of head wall into the gully sides. It permits stable fill and prevents piping (due to seepage) around the structure. Its main function is to provide structural strength against sliding of the structure and also to prevent the flow of water from the sides of the drop spillway.
3. **Wing Walls:** These are constructed at the rear end of the structure with some inclination, usually at 45° from the vertical. These walls are extended up to the gully sides and perform the function of preventing the flow backward into the space left between gully wall and side wall of the structure. They provide stability to the fill and protect the gully banks and surface.
4. **Cut-off Walls:** These are constructed to provide structural strength against sliding of the structure. They increase frictional resistance of the structure which opposes the force causing the slide. In other words, cut-off walls act as a key for the structure, prevent piping under the structure besides reducing uplift and sliding.
5. **Toe Walls:** Prevent undercutting of apron.
6. **Side Walls:** These are constructed in the side along the gully walls. They guide the water and protect the fill against erosion. The function of the side walls is to prevent splashing of water over the gully banks and also to confine the water flow within the apron.
7. **End Sills:** These are the elevated portion of rear end of the apron. Its main function is to obstruct the water from directly moving into the channel below. They also raise the tail water level to create hydraulic jump and to dissipate the energy of the flowing water.
8. **Longitudinal Sills:** These are constructed in the apron section. They are constructed lengthwise parallel to the side walls. The sills are useful to make the apron stable.
9. **Apron:** It is one of the main downstream components of the straight drop spillway as it receives the gully flow with high velocity and changes the flow regime so as to minimize the soil erosion on the downstream channel. It includes several elevated blocks to make the apron surface rough. This feature of apron is responsible for dissipating the maximum kinetic energy of falling water by creating hydraulic jump. As a result the velocity of outflow water is significantly reduced.

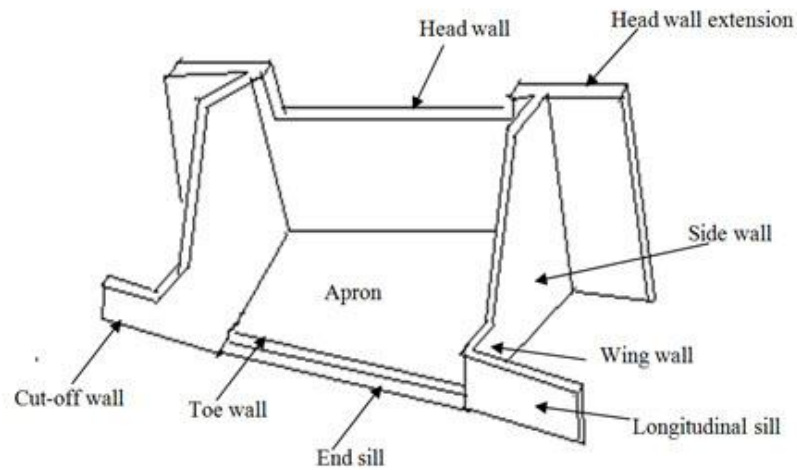

Fig. 8.1. Drop spillway.

The drop structure is used to control the velocity of runoff in a channel by allowing the water to fall from higher elevation to much lower elevation. The main three purposes of drop spillways are as follows:

1. To provide a transition between a broad or flat waterways and ditch or gully section.
2. To raise the flow line to allow formation of sufficient soil depth for vegetative growth where bottom of the gully is at risk.
3. To raise the flow line of the waterway so as to provide drainage in case of wet waterways.

8.6.2 Uses of Drop Spillway

1. To control gradient in either natural or constructed channels, To control tail-water at the outlet of a spillway or conduit.
2. To serve as a reservoir spillway where the total drop is relatively low.
3. To serve as inlet and outlet structures for tile drainage system in conjunction with gradient control.
4. To use as grade stabilization in lower reaches of waterways and outlets.
5. To use as erosion control, to protect the roads, buildings etc.
6. Straight drop spillway as an outlet in tile drainage system and for releasing the irrigation water into the field in irrigation system.
7. In the reservoir, for letting out the water through low height drop spillway of less than 3 m,
8. For controlling irrigation in the water distribution system and
9. As an outlet for disposing surface water from large areas, especially with drainage ditches.

8.6.3 Material for Construction

For most soil conditions, drop spillways may be built of any of the construction materials adapted for use in hydraulic structures. It may be concrete, masonry, concrete blocks etc. Reinforced concrete is most widely used and has been very satisfactory in terms of long life and low annual cost. In case a number of structures are involved, the selection of material should be based on the required life span of structures and annual cost comparison, which includes maintenance, of the structures built of different available material.

8.6.4 Advantages

1. Stability: It is very stable and likelihood of serious structural damage is remote.
2. Non-Clogging of Weir: As rectangular weir is used in this case, there is less likelihood of clogging by debris.
3. Maintenance cost is low.
4. It is relatively easy to construct and economical.
5. Standardization: The designs may be standardized which result in savings in engineering and constructional costs.
6. The danger of undermining by rodents is not possible in this structure.

8.6.5 Disadvantages

1. Use is limited to a maximum drop of 3 m. They may be costlier than other structure.
2. It is not a favourable structure where it is desired to use temporary spillway storage to obtain a large reduction in the discharge at or downstream from the structure.
3. In the areas where discharge is less than $3 \text{ m}^3/\text{s}$, the construction of straight drop spillway proves to be costly affair, and thus should not be preferred.
4. If the gully grade below the structure is not stable then it is impossible to construct a drop spillway.

8.7 Design of Drop Spillway

In general, the hydraulic structures fail mainly due to their insufficient hydraulic capacity and lack of provision for dissipating the energy of falling water into the structure. That is why, design of these structures is done considering not only to have sufficient discharge handling capacity, but also for dissipating the kinetic energy of the falling discharge within the structure in such a manner that will protect the structure and downstream channel from scouring.

8.7.1 Hydrologic Design

It involves the estimation of design runoff rate and flood volume which the structures have to handle safely. Runoff rate is calculated by the rational method.

8.7.2 Hydraulic Design

The design consists of determining the length of crest (L), and depth (h) of the weir to provide required capacity and to maintain an adequate freeboard under free flow condition. The design of drop structure is done using the following steps.

(a) Inlet Design: Straight drop spillway consists of a straight type inlet due to which it is named as straight drop spillway. This type of inlet is most suitable for wide and shallow gullies to handle small to medium flows. To calculate the inflow capacity of straight drop spillway, the following weir formula may be used:

$$Q = CL\left(H + \frac{V_a^2}{2g}\right)^{\frac{3}{2}} \quad (8.1)$$

where, Q = peak discharge rate (m^3/s) which is to be handled by the structure; L = Length of crest (m); H = head over the crest (m); V_a = mean velocity of approach (m/s), C = coefficient of discharge. The value of C commonly used is 1.72. Thus, substituting the value of C in the above equation we have,

$$Q = 1.72L\left(H + \frac{V_a^2}{2g}\right)^{\frac{3}{2}} \quad (8.2)$$

The above formula can only be applied if the crest of the weir is not submerged to a depth

greater than $d_c/3$ (d_c is critical depth, $d_c = \sqrt[3]{\frac{Q^2}{L^2g}}$) by the tail water i.e. free flow condition is maintained. If the flow becomes submerged then the coefficient of discharge alters from the value of 1.72. The remaining two parameters i.e. length of crest (L) and depth of weir (h) are calculated as:

$$h = f + H + \frac{V_a^2}{2g} \quad (8.3)$$

$$L = \frac{Q}{\sqrt{d_c^3g}} \quad (8.4)$$

Another formula can be used for the calculation of the inflow capacity for submerged flow is given as:

$$Q = \frac{2}{3} C_d \sqrt{2g} LH^{\frac{3}{2}} \quad (8.5)$$

where, C_d = coefficient of discharge and its value varies with the entrance condition (0.6); g = acceleration due to gravity (9.81 m/s^2). By substituting the value of C_d and g in the above equation we have,

$$Q = 0.017 LH^{\frac{3}{2}} \quad (8.6)$$

By applying the above equation, L and H are determined using trial and error method to satisfy the Q value. A free board in the range of 15 to 30 cm is added to H to get the height of the side wall over the crest.

(b) Outlet Design: Outlet design is made with the considerations that the kinetic energy gained by the sheet of flowing water while falling from the crest of gully head to the downstream side of the structure must be dissipated and/or converted into potential energy. The preliminary calculations to design the outlet are performed by using the following two terms:

i) Froude Number: It may be calculated by the following formula:

$$F = \frac{v}{\sqrt{gd}} \quad (8.7)$$

where, F = Froude number (dimensionless); v = velocity of flowing water entering into the apron to create the jump (m/s); d = depth of flow at entrance (m).

When $F = 1$, $v = \sqrt{gd}$, under this condition, the flow is said to be in critical state. If $F < 1$ or $v < \sqrt{gd}$ the flow is referred as sub-critical flow. In this case gravity force is dominant which results in reduction of flow velocity. Similarly, if $F > 1$ or $v > \sqrt{gd}$ the flow is super critical flow. In this state, the inertial forces become more dominant than the gravity force causing increase in the flow velocity. In outlet design, attempts are made to convert the flow velocity to sub-critical range, by creating hydraulic jump inside the outlet.

ii) Hydraulic Jump: Depth of flow increases when flow changes from super-critical to sub-critical state. This increase in depth of flow over a very short length is known as hydraulic jump. In the process of development of hydraulic jump, a high degree of turbulence is created which is responsible for dissipating the energy.

(c) Design of Component Parts:

i) Height of transverse sill (S):

$$S = \frac{d_c}{2} \quad (8.8)$$

ii) Height of headwall (HB): $HB = F + S$ (8.9)

iii) Height of headwall extension (HE): $HE = F + S + h$ (8.10)

iv) Minimum length of headwall extension (E): $E = 3h + 0.6$ or $1.5F$ whichever is more. (8.11)

v) Minimum length of apron (L_B): Whichever is more,

$$L_B = F \left[2.3 \frac{h}{F} + 0.5 \right] \text{ or } 2[F + S + h + 0.3 - J] \quad (8.12)$$

vi) Height of side wall and wing wall at the junction (J). Whichever is greater,

$$J = 2h \text{ or } \left[F + h + S - \frac{(L_B + 0.13)}{2} \right] \quad (8.13)$$

vii) Depth of cutoff wall (c) and toe wall (T):

$$C = T = \frac{1.65(S + 0.4F + 0.75)}{4} \quad (8.14)$$

8.7.3 Structural Design

It involves the determination of strength and stability of different parts of the structure. The various forces which act on the structure are mainly static water pressure, force due to overflow and effect of water flow below the structure (i.e. seepage and sub-surface flow). The structural design comprises estimation of horizontal pressure (equivalent fluid pressure), uplift pressure, contact pressure and factor of safety.



AGRIMOON.COM
All About Agriculture...

Lesson 9 Drop Inlet Spillway

A drop inlet or shaft spillway is one in which the water enters through a horizontally positioned circular or rectangular box type riser or inlet and flows to some type of outlet protection through a circular (horizontal or near horizontal) conduit. The drop inlet spillway is ideally suited to conditions when there is need to control the downstream channel flow by providing a temporary storage upstream of the structure. It consists of an earthen dam and a pipe spillway. The dam provides the temporary storage of runoff from the contributing watershed while the spillway permits the design discharge to pass downstream (Fig. 9.1). It is adapted where drop is > 3.0 m. The drop inlet structure (Fig. 9.1) consists of the inlet, conduit and the outlet. Where the inlet is funnel shaped, this type of structure is often called as Morning glory or Glory hole spillway.

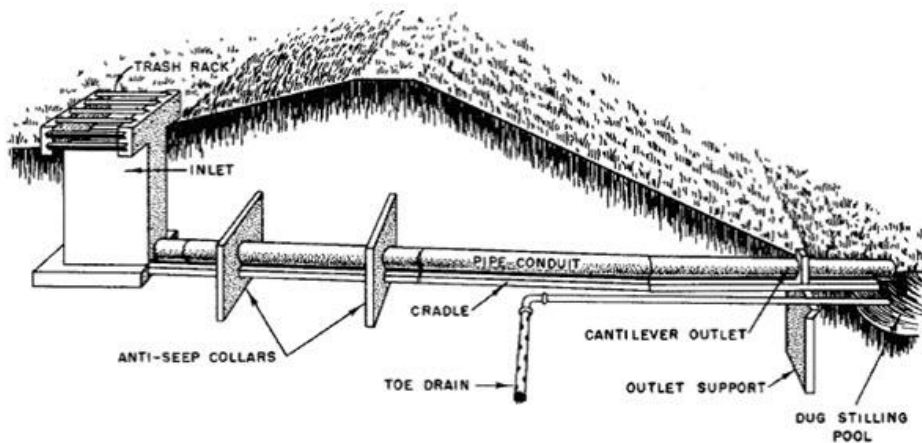

Fig. 9.1. Drop inlet spillway and its components.

Advantages

- Drop inlet structures are used in gullies towards the downstream part to create storage of water.
- These structures not only help in protecting gullies but also create water storage.
- The stored water could be useful for irrigation or other farm use purposes.
- A large number of drop inlet structures will have a retarding effect on downstream flows. A reduction in the sediment load could also occur.
- An earthen embankment helps in storing the water and the drop inlet essentially lets out the excess water safely.
- These are frequently used for headwater flood control and as outlets for farm ponds and reservoirs, silt detention reservoirs and settling basins.
- They are suitable as gully control structures for the stabilization and control of advancing gully heads when the gully is more than 3 m deep.
- They are relatively simple to build.

9.1 Design of Drop Inlet Spillways

The design consists of hydrologic and hydraulic designs.

9.1.1 Hydrologic Design

The hydrologic design of the drop inlet structure consists of knowing both the peak rate of runoff expected and also the inflow hydrograph. The latter is needed as temporary storage of water is created in case of these structures. The outflow will not be same as the inflow like in drop or chute spillways.

9.1.2 Hydraulic Design

To understand the hydraulic design of the structure, the different types of flow that occur in the conduit are to be considered. The flow through the structure could be controlled first by the inlet and latter by the conduit. A typical discharge characteristic curve is shown in Fig. 9.2. To calculate the inflow capacity of straight drop inlet spillway, the following weir formula is used.

$$Q = \frac{2}{3} C_d \sqrt{2g} L H^{\frac{3}{2}} \quad (9.1)$$

where, Q = peak discharge rate to be handled by the structures (m^3/s); g = acceleration due to gravity (9.81 m/s^2); H = head over the crest (m); C_d = coefficient of the discharge (0.6). A free board is also added to H . Generally 15 to 30 cm of free board is added to the calculated value of H .

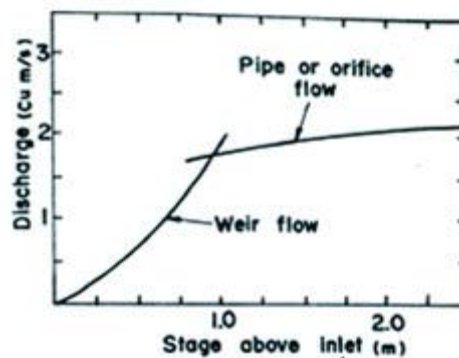

Fig. 9.2. Discharge characteristic curve of a drop inlet spillway.

(Source: Murty and Jha, 2011)

The flow through the conduit is governed by the slope given to it. There is also loss of head due to friction (H_f) during the flow and it is given by:

$$H_f = LK_c \frac{v^2}{2g}$$

where L = length of the pipe (m); v = velocity of flow (m/s); K_c = head loss coefficient.

The slope of the pipe is given by:

$$S = \tan \theta = \frac{H}{\sqrt{L^2 - H^2}} \approx \sin \theta \quad (9.3)$$

Neutral slope (S_n) is a hydraulic slope in which the head loss due to friction is equal to the head loss due to elevation change in the conduit.

$$S_n = \frac{H_f}{L} = K_e \frac{v^2}{2g} \quad (9.4)$$

Different flow conditions possible are shown in Fig. 9.3 (a), (b) and (c). When the conduit has a slope less than the neutral slope and the inlet is submerged the conduit will flow full (Fig. 9.3a). Pipe flow condition prevails and the capacity of the conduit under the conditions shown in Fig. 9.3 (a) and (c) is given by:

$$Q = \frac{a\sqrt{2gH}}{\sqrt{1 + K_e + K_e L}} \quad (9.5)$$

where a = area of cross section of the conduit (m^2) and K_e = coefficient of entrance losses.

If the conduit is at greater than neutral slope and the outlet is not submerged (Fig. 9.3b), the flow will be controlled by the inlet section of the conduit. In such a case the discharge (Q) is calculated using the orifice formula:

$$Q = ac\sqrt{2gH} \quad (9.6)$$

where c = the coefficient of discharge for the orifice (obtained from hydraulic tables).

Using these formulae for the discharge characteristics of the drop inlet (shown in Fig. 9.2) is prepared. From the site conditions, the information relating to the stage (water level above the level of the inlet) and the storage capacity can also be determined. Using the inflow hydrograph, storage-capacity curve and the discharge characteristics of the structure, the outflow hydrograph of the structure can be worked out using the *flood routing* procedure. For the design storm hydrograph selected, the storage capacity and the discharge characteristics of the structure selected should be such that the temporary storage will not exceed the design depth for the embankment.

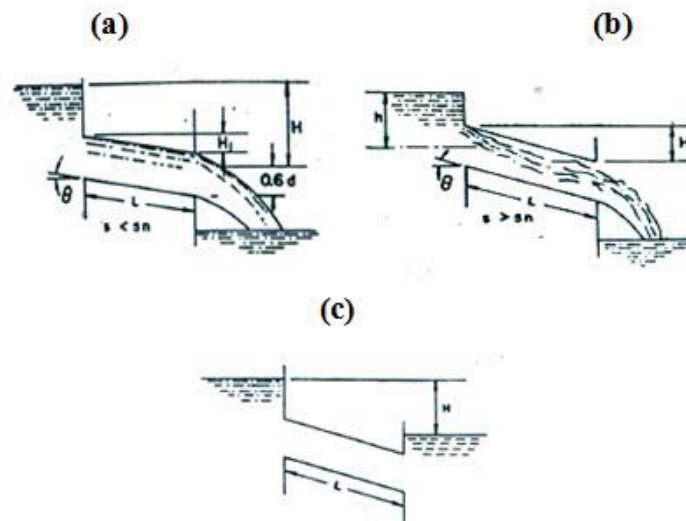

Fig. 9.3. Different flow conditions (a) Full free outfall pipe flow; (b) Part full: free outfall orifice flow; (c) Full: outfall submerged pipe flow in drop inlet spillway.

9.2 Components of Drop Inlet Spillway

The different components of the drop inlet spillway are shown in Fig. 9.4. The construction of the earthen embankment will have to be done in the same manner as the earth darns or embankments. Other features of the drop inlet spillway are as follows:

- **Anti-seep Collars:** These are provided on the conduit pipe and are constructed using concrete masonry. These are necessary for control of seepages and prevention of failure due to piping. The total length of the seepage collars should be nearly 30 per cent of the total length of seepage and to get this length two or more seepage collars are provided. The anti-seep collars shall be placed within the saturated zone. The normal saturation zone may be determined by projecting a line at a slope of 4 horizontal to 1 vertical from the point where the normal water elevation touches the upstream slope of the fill to a point where this line intersects the invert of the pipe barrel. All soil fill located below this line may be assumed as saturated.
- **Cradle to the Conduit:** To prevent uneven settlement and to develop hoop stress in the concrete pipes a cradle of masonry or concrete is provided to the conduit. Concrete pipes withstand more loads when hoop stress is developed than otherwise.
- **Emergency Spillway:** If the runoff exceeds the design runoff, there is a danger of overtopping of the embankment and failure of the structure. To prevent such an occurrence, an emergency spillway is located on the embankment at the convenient location. The emergency spillway leads to downstream of the structure. The channel of the emergency spillway is protected with grass or stone pitching. The flood routing procedure gives the elevation at which the emergency spillway is to be located.
- **Stone Pitching:** Stone pitching is recommended on the upstream side on the embankment and downstream side beyond the outlet to prevent soil erosion.
- **Filters:** Sand and gravel filters are provided to help drainage and prevent piping.

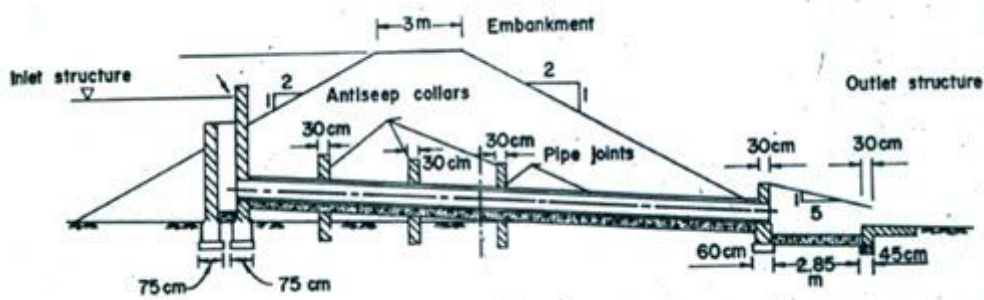

Fig. 9.4. Components of drop inlet spillway. (Source: Murty and Jha, 2011)

Problem 9.1

Determine the size of concrete pipe needed in a drop-inlet spillway for a peak flow of $2 \text{ m}^3/\text{s}$ and a total head of 3 m. Determine the slope to be given to the pipe for the pipe to flow full. Length of pipe = 12 m, entrance loss coefficient $K_e = 0.5$ and friction loss coefficient $K_c = 0.03$.

Solution

$$\text{Velocity of water in pipe, } v = \frac{\sqrt{2gH}}{\sqrt{1+K_e+K_cL}}$$

$$= \frac{\sqrt{2 \times 9.81 \times 3}}{\sqrt{1+0.5+(0.03 \times 12)}} = 5.63 \text{ m/s}$$

$$Q = A \times v \text{ or } A = \frac{Q}{v}$$

$$A = \frac{2}{5.63} = 0.355 \text{ m}^2$$

$$\frac{\pi}{4} d^2 = 0.355 \text{ m}^2$$

$\therefore d = 0.67 \text{ m}$ or select 75 cm diameter pipe.

$$S_n = \frac{K_c \frac{v^2}{2g}}{\sqrt{1 - \left(K_c \frac{v^2}{2g} \right)}}$$

Neutral slope,

Neglecting the second term in denominator as it is very much less than 1.0.

$$\therefore S_n = K_c \frac{v^2}{2g}$$

$$\therefore S_n = \frac{0.03 \times (5.63^2)}{2 \times 9.81} = 0.048$$

The downstream end of the pipe is kept 30 cm below the upstream end.

Actual slope, $S = 0.3/12 = 0.025$

As $S < S_n$, the pipe will flow full.



AGRIMOON.COM

All About Agriculture...

Lesson 10 Chute Spillway

Chute (open channel or trough) spillway is a spillway whose discharge is conveyed from the upper reach of the channel or a reservoir to the downstream channel level through an open channel placed along a dam, abutment (supporting wall), or through a saddle. Chute structures are useful for gully head control and they could be used for drops upto 5 to 6 m. Chute spillways are constructed at the gully head to convey the discharge from upstream area of gully into the gully through a concrete or masonry open channel, when drop height exceeds the economic limit of drop structures. Chute spillway has more advantage than a drop spillway, when a large runoff volume is required to be discharged from the area. Flow in a chute spillway is at super-critical velocities.

10.1 Components of Chute Spillway

The chute spillway consists of the following three design components (Fig. 10.1):

- **Inlet or Entrance Channel:** The most common type of inlets used in chute spillways are the straight inlet, box type inlet and sometimes side channel inlet also. The box type inlet is generally used in a situation when straight type inlet is not sufficient to carry the runoff at the desired drop.
- **Channel Section or Conduit:** In chute spillway, the rectangular type conduits are mostly common. The side walls of conduit confine the flow rate and discharge distribution. The top edge of side walls is constructed in such a way that it may be flushed with the embankment slope. The vertical curve section is continued through the channel in such a manner so that it conveys and guides the discharge to the lower elevation without erosion.
- **Outlet:** The outlet dissipates the energy of the flowing water and provides non-erosive velocity downstream. Straight apron type outlets are most commonly used in small gully control structures.

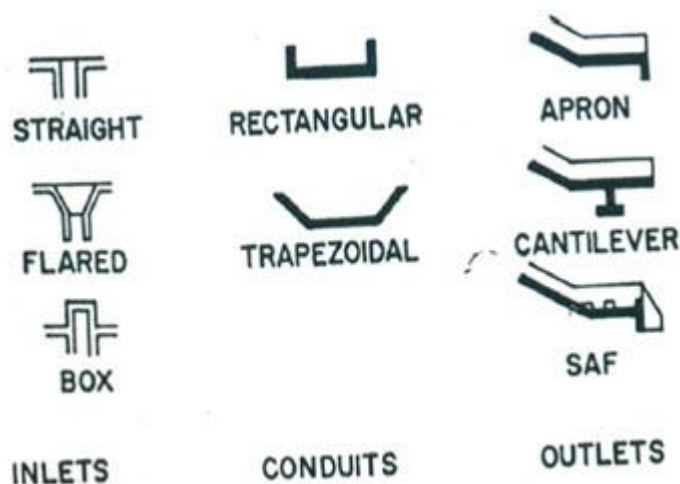

Fig. 10.1. Components of Chute Spillway. (Source: Michael and Ojha, 2012)

10.2 Applicability

- In general, chute spillways are used whenever a channel is to be constructed down a steep slope.
- They are preferred over drop spillways when the drop exceeds the economic limits of the latter.
- It is superior to a drop inlet spillway when large discharges are required to be conveyed. When there is no opportunity to provide temporary storage, the chute spillway with its inherent high capacity is preferred over the drop inlet spillway.
- Chute spillways are frequently used in combination with earth dams to drop water farther than is feasible with drop structures. The capacity of a chute spillway is not reduced due to sedimentation at the outlet.
- However, sometimes there is a danger that rodents may undermine the structure and in poorly drained locations seepage may endanger the foundations.

10.3 Material for Construction

- A chute spillway usually requires less masonry or concrete than a drop structure of the same capacity and drop.
- To minimize problems of settling and undermining, chute spillways are constructed on foundations on solid ground or on fill that has been carefully compacted under controlled conditions.
- Reinforced concrete, brick, or stone masonry are used for chute construction.

10.4 Design Features

Design of a chute spillway includes the design of the inlet, the channel section and the outlet.

Inlet: The design procedure for inlets is the same as described under drop spillways. The discharge that the spillway is expected to convey is determined from hydrological data. The capacity of a chute spillway is usually controlled by the inlet section. The details of the inlet structure are shown in Fig. 10.2. The inlets convey and guide the designed discharge and provide cutoff of flow by piping under and around the chute channel. To calculate the inflow capacity of chute spillway, the following weir formula may be used:

$$Q = 1.66LH^{\frac{3}{2}} \quad (10.1)$$

where, Q = peak discharge rate (m^3/s) which is to be handled by the structure; L = Length of crest (m) and H = head above the crest (m).

Velocity of flow (v) is given by:

$$Q = 1.66LH^{\frac{3}{2}} \quad (10.2)$$

where h_f = frictional head loss over the apron (m); h = total drop.

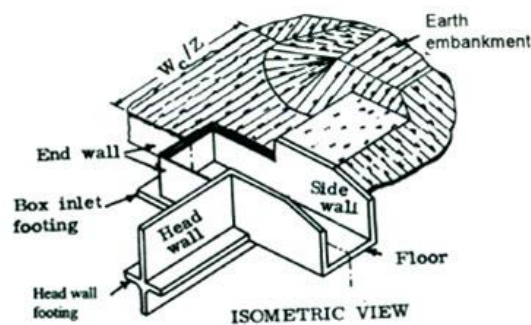

Fig. 10.2. Rectangular Weir Box Inlet for Chute Spillways.

Channel Section: Design of channel cross-section is similar to the design of open channel, in which bottom width, top width, side slope and depth are determined for a given discharge rate. For this purpose, Manning's formulae is used.

Outlet: The design principle of outlet of chute spillway is similar to the design of outlet of drop structures (Fig. 10.3). The hydraulic jump is used as the means of energy dissipation. In the design of outlets using the hydraulic jump, the sequent-initial depths ratio (y_2/y_1) is important. Here y_1 and y_2 are the flow depths before and after the jump respectively.

In a rectangular channel the depth ratio is:

$$\frac{y_2}{y_1} = \frac{1}{2\left(\sqrt{1+8F_n^2} - 1\right)} \quad (10.3)$$

where, F_1 = Froude number is given by $\frac{v_1}{\sqrt{gy_1}}$; v_1 = the flow velocity before occurrence of hydraulic jump (m/s); g = acceleration due to gravity (m/s^2).

The Saint Anthony Falls (SAF) stilling basin type outlet provides an adequate facility for dissipation of kinetic energy.

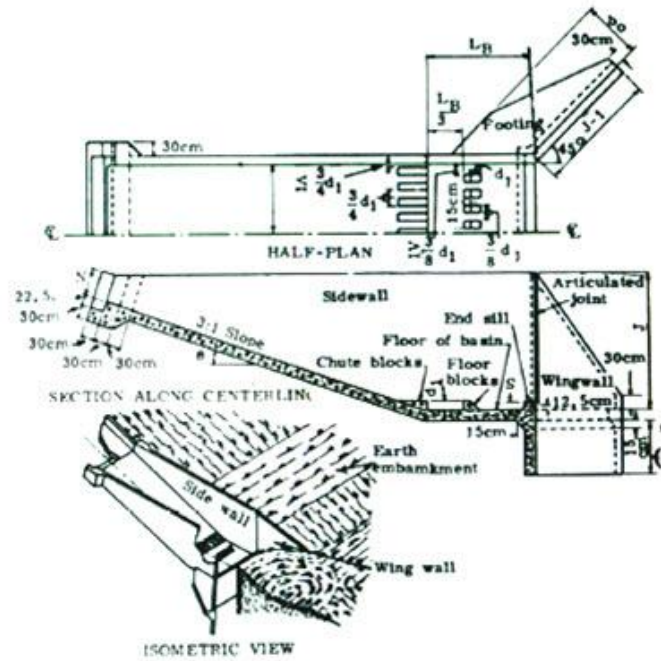

Fig. 10.3. Outline Section of Chute Spillway Provided with SAF Stilling Basin.

10.4.1 Design of Saint Anthony Falls (SAF) Stilling Basin

The SAF stilling basin (Fig. 10.4) gives adequate performance for a range of Froude numbers varying from 1.7 to 17. The criteria for the design of SAF stilling basins are as follows:

Referring to Fig. 10.4, the dimensions of different components of SAF stilling basin are given as:

- Length of stilling basin (L_B):

$$L_B = \frac{4.5 y_2}{F_n^{0.176}} \quad (10.4)$$

- Width and spacing of the chutes and floor blocks = $0.75 y_1$; where y_1 = height of the chute and floor blocks.

- Spacing of floor blocks from upstream end of the stilling basin = $\frac{L_B}{3}$

- The floor blocks should not be closer than $\frac{3y_1}{8}$ from the side walls of the basin.
- The location of the floor blocks should be fixed at downstream side from the openings between the chute blocks.
- The height of the end sill should be equal to $0.07 y_2$, in which y_2 stands for theoretical tail water depth, corresponding to initial flow depth y_1 .

- The actual depth of tail water above the stilling basin may be computed by the following equation:

$$y_2' = \left(1.10 - \frac{F_n}{120}\right) y_2, \text{ for } F_n = 1.7 \text{ to } 5.5 \quad (10.5)$$

$$y_2' = 0.85 y_2, \text{ for } F_n = 5.5 \text{ to } 11 \quad (10.6)$$

$$y_2' = \left(1.00 - \frac{F_n^2}{800}\right) y_2, \text{ for } F_n = 11 \text{ to } 17 \quad (10.7)$$

- The height of side wall above the maximum tail water depth (y_3) is given by:
- The height of wing wall should be equal to the height of stilling basin's side wall.
- The top of the wing wall should be inclined at 1:1 slope.
- The length of the wing wall should be equal to $y_2' + y_3 \cdot y_2' + J$.
- The wing wall may be inclined at angle of 45° from the center line of the outlet.
- In order to make the structures safe against sliding, a cutoff wall of nominal depth should be provided at the end of stilling basin.
- In the design of stilling basin, the effect of entrained air should be neglected.

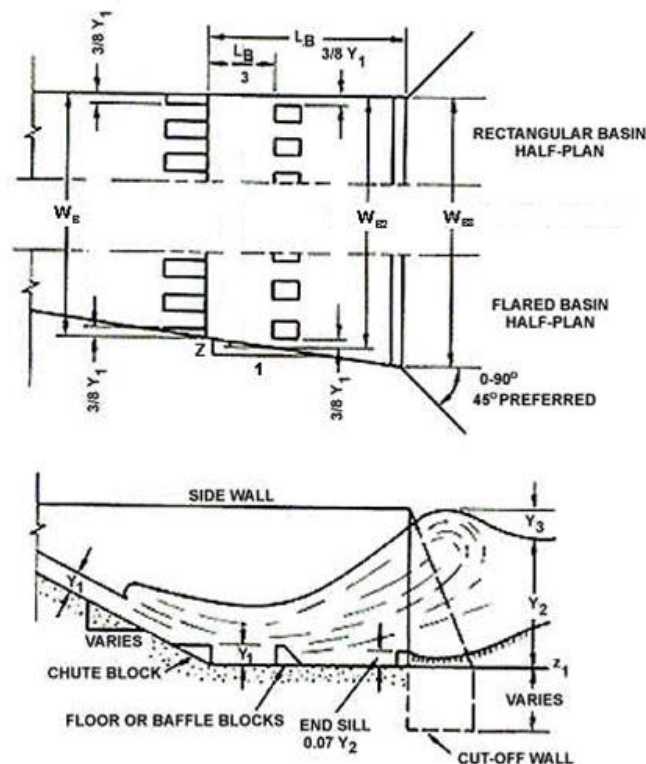

Fig. 10.4. Rectangular Weir Box Inlet for Chute Spillways.

Lesson 11 Earthen Dam

An earthen embankment is a raised confining structure made from compacted soil. The purpose of an earthen embankment is to confine and divert the storm water runoff. It can also be used for increasing infiltration, detention and retention facilities. Earthen embankments are generally trapezoidal in shape and most simple and economic in nature. They are mainly built with clay, sand and gravel, hence they are also known as earth fill dams or earthen dams. They are constructed where the foundation or the underlying material or rocks are weak to support the masonry dam or where the suitable competent rocks are at greater depth. They are relatively smaller in height and broader at the base.

11.1 Components of An Earthen Dam

The various components of an earthen dam are shown in Fig. 11.1.

1. **Shell, Upstream Fill, Downstream Fill or Shoulder:** These components of the earthen dam are constructed with pervious or semi-pervious materials upstream or downstream of the core. The upstream fill is called the upstream shell and the downstream portion is the downstream shell.
2. **Upstream Blanket:** It is a layer of impervious material laid on the upstream side of an earthen dam where the substratum is pervious, to reduce seepage and increase the path of flow. The blanket decreases both the seepage flow and excess pressure on the downstream side of the dam. A natural blanket is a cover of naturally occurring soil material of low permeability.
3. **Drainage Filter:** It is a blanket of pervious material constructed at the foundation to the downstream side of an earthen dam, to permit the discharge of seepage and minimize the possibility of piping failure.
4. **Cutoff Wall or Cutoff:** It is a wall, collar or other structure intended to reduce percolation of water through porous strata. It is provided in or on the foundations.
5. **Riprap:** Broken stones or rock pieces are placed on the slopes of embankment particularly the upstream side for protecting the slope against the action of water, mainly wave action and erosion.
6. **Core Wall, Membrane or Core:** It is a centrally provided fairly impervious wall in the dam. It checks the flow of water through the dam section. It may be of compacted puddled clay, masonry, or concrete built inside the dam.
7. **Toe Drain:** It is a drain constructed at the downstream slope of an earthen dam to collect and drain away the seepage water collected by the drain filters.
8. **Transition Filter:** It is a component of an earthen dam section which is provided with core and consists of an intermediate grade of material placed between the core and the shells to serve as a filter and prevent lateral movement of fine material from the core.

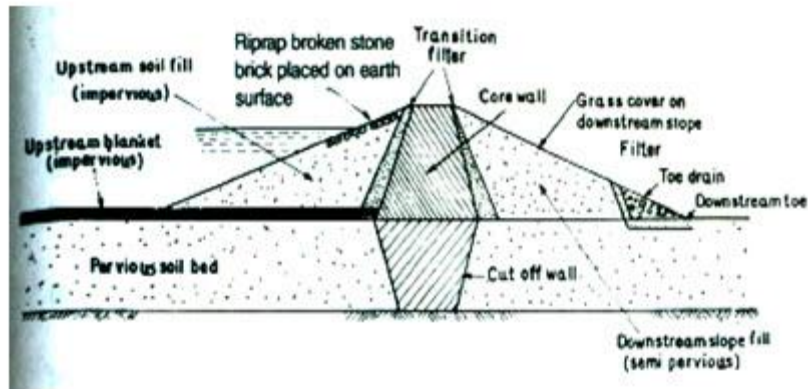

Fig. 11.1. Cross-section of an Earthen Dam with Various Components.

11.2 Advantages

1. Design procedures are straightforward and easy.
2. Local natural materials are used.
3. Comparatively small establishment and equipment are required.
4. Earth fill dams resist settlement and movement better than more rigid structures and can be more suitable for areas where earth movements are common.

11.3 Disadvantages

1. An earthen embankment is easily damaged or destroyed by water flowing on, over or against it. Thus, a spillway and adequate upstream protection are essential for any earthen dam.
2. Designing and constructing adequate spillways is usually the most technically difficult part of any dam building work. Any site with a poor quality spillway should not be used.
3. If it is not adequately compacted during construction, the dam will have weak structure prone to seepage.
4. Earthen dams require continual maintenance to prevent erosion, tree growth, subsidence, animal and insect damage and seepage.

11.4 Types of Earthen Dam

1. Based on the method of construction:

(a) Rolled Fill Earthen Dams: In this type of dams, successive layers of moistened or damp soils are placed one above the other. Each layer not exceeding 20 cm in thickness is properly consolidated at optimum moisture content maintained by sprinkling water. It is compacted by a mechanical roller and only then the next layer is laid.

(b) Hydraulic Fill Earthen Dam: In this type of dams, the construction, excavation and transportation of the earth are done by hydraulic methods. Outer edges of the embankments are kept slightly higher than the middle portion of each layer. During construction, a mixture of excavated materials in slurry condition is pumped and discharged at the edges.

This slurry of excavated materials and water consists of coarse and fine materials. When it is discharged near the outer edges, the coarser materials settle first at the edges, while the finer materials move to the middle and settle there. Fine particles are deposited in the central portion to form a water tight central core. In this method, compaction is not required.

2. Based on the mechanical characteristics of earth materials used in making the section of dam:

(a) **Homogeneous Earthen Dams:** It is composed of one kind of material (excluding slope protection). The material used must be sufficiently impervious to provide an adequate water barrier, and the slopes must be moderately flat for stability and ease of maintenance (Fig. 11.2).

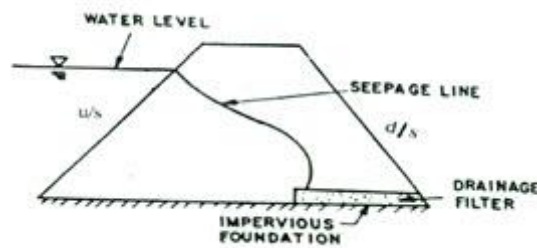

Fig. 11.2. Homogenous Earthen Dam.

(b) **Zoned Earthen Dams:** It contains a central impervious core, surrounded by zones of more pervious material, called shells. These pervious zones or shells support and protect the impervious core (Fig. 11.3).

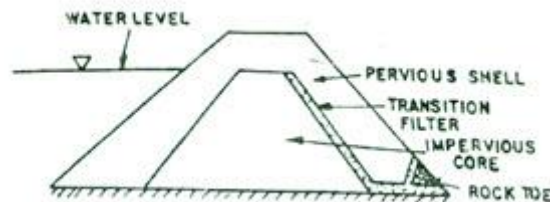

Fig. 11.3. Zoned Earthen Dam.

(c) **Diaphragm Earthen Dam:** This type of dam (Fig. 11.4) is a modified form of homogenous dam which is constructed with pervious materials, with a thin impervious diaphragm in the central part to prevent seepage of water. The thin impervious diaphragm may be made of impervious clayey soil, cement concrete or masonry or any impervious material. The diaphragm can be constructed in the central portion or on the upstream face of the dam. The main difference in zoned and diaphragm type of dams depends on the thickness of the impervious core or diaphragm. The thickness of the diaphragm is not more than 10 m.

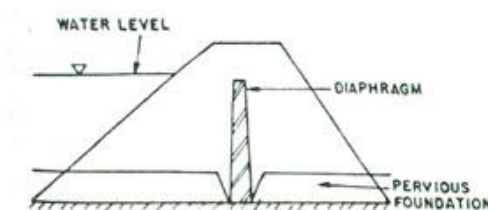

Fig. 11.4. Diaphragm Earthen Dam.

11.5 Design Criteria

Following main design criteria may be laid down for the safety of an earth dam:

1. To prevent hydraulic failures the dam must be so designed that erosion of the embankment is prevented. For this purpose, the following steps should be followed:
 - (a) Spillway capacity is sufficient to pass the peak flow.
 - (b) Overtopping by wave action at maximum water level is prevented.
 - (c) The original height of structure is sufficient to maintain the minimum safe freeboard after settlement has occurred.
 - (d) Erosion of the embankment due to wave action and surface runoff does not occur.
 - (e) The crest should be wide enough to withstand wave action and earthquake shock.
2. To prevent the failures due to seepage:
 - (a) Quantity of seepage water through the dam section and foundation should be limited.
 - (b) The seepage line should be well within the downstream face of the dam to prevent sloughing.
 - (c) Seepage water through the dam or foundation should not remove any particle or in other words cause piping.
 - (d) There should not be any leakage of water from the upstream to the downstream face. Such leakage may occur through conduits, at joints between earth and concrete sections or through holes made by aquatic animals.
3. To prevent structural failures:
 - (a) The upstream and downstream slopes of the embankment should be stable under all loading conditions to which they may be subjected including earthquake.
 - (b) The foundation shear stresses should be within the permissible limits of shear strength of the material.

11.6 Design of Earthen Dam

The preliminary design of earthen dam is done on the basis of past experiences. For designing purpose several parameters, given below should be considered.

1. Top Width
2. Free Board
3. Settlement Allowance
4. Casing or Outer Shell
5. Cut-off Trench

6. Downstream Drainage System

1. Top Width: Minimum top width (W) should be such that it can enhance the practicability and protect it against the wave action and earth wave shocks. Sometimes it is also used for transportation purposes. It depends upon the height of the earthen dam and can be calculated as follows:

$$W = \frac{H}{5} + 3 \quad (\text{for very low dam}) \quad (11.1)$$

$$W = 0.55\sqrt{H} + 0.2H \quad (H \leq 30) \quad (11.2)$$

$$W = 1.65\sqrt[3]{H} + 1.5 \quad (H \geq 30) \quad (11.3)$$

where H = the height of the dam (m), for Indian conditions it should not be less than 6 m.

Free board: It is the vertical distance between the top of the dam and the full supply level of the reservoir or the added height. It acts as a safety measure for the dam against high flow condition that is waves and runoff from storms greater than the design frequency from overtopping the embankment. The Recommended values of free board for different heights of earthen dams, given by U.S.B.R., are given in Table 11.1.

Table 11.1. Recommended Values of Free Board given by U.S.B.R.

Nature of spillway	Height of dam	Free board
Free	Any	Minimum 2 m and maximum 3 m over the maximum flood level
Controlled	< 60 m	2.5 m above the top of the gate
Controlled	> 60 m	3 m above the top of the gate

If fetch length or exposure is given then the free board can also be calculated by Hawksley's formula:

$$h_w = 0.014D_m^{0.5} \quad (11.4)$$

where, h_w = wave height (m); D_m = fetch or exposure (m).

2. Settlement Allowance: It is the result of the settlement of the fill and foundation material resulting in the decrease of dam storage. It depends upon the type of fill material and the method and speed of construction. It varies from 10% of design height for hand compacted to 5% for machine compacted earthfill.

3. Casing or Outer Shell: Its main function is to provide stability and protection to the core. Depending upon the upstream and downstream slopes, a recommendation for the casing and outer shell slopes for different types of soils given by Terzaghi is presented in Table 11.2.

Table 11.2. Recommended Slopes of Earthen Dam (Sources: S.K. Garg, 2008)

Sl. No.	Types of material	u/s slope	d/s slope
1.	Homogenous well graded material	$2\frac{1}{2}:1$	2:1
2.	Homogenous coarse silt	3:1	$2\frac{1}{2}:1$
3.	Homogenous <u>silty</u> clay or clay		
	a) Height less than 15 m	$2\frac{1}{2}:1$	2:1
	b) Height more than 15 m	3:1	$2\frac{1}{2}:1$
4.	Sand or sand and gravel with clay core	3:1	$2\frac{1}{2}:1$
5.	Sand or sand and gravel with R.C. core wall	$2\frac{1}{2}:1$	2:1

Cutoff Trench: It is provided to reduce the seepage through the foundation and also to reduce the piping in the dam. It should be aligned in a way that its central line should be within the upstream face of the impervious core. Its depth should be more than 1 m. Bottom width of cutoff trench (B) is calculated as:

$$B = h - d \quad (11.5)$$

where h = reservoir head above the ground surface (m); and d = depth of cutoff trench below the ground surface (m).

4. Downstream Drainage System: It is performed by providing the filter material in the earthen dam which is more pervious than the rest of the fill material. It reduces the pore water pressure thus adding stability to the dam.

Three types of drains used for this purpose are:

- a) Toe Drains
- b) Horizontal Blanket
- c) Chimney Drains.

Lesson 12 Stream Bank Erosion

12.1 Introduction

Rivers and streams are products of their catchments. They are often referred to as dynamic systems which mean they are in a constant state of change. The factors controlling river and stream formation are complex and interrelated. These factors include the amount and rate of supply of water and sediment into stream systems, catchment geology and the type and extent of vegetation in the catchment. As these factors change over time, river systems respond by altering their shape, form and/or location. In stable streams the rate of these changes is generally slow and imperceptible.

Erosion is the removal of soil particles from a site due to the forces of water, wind and ice. Over time, these forces slowly wear away or disintegrate the soil. In case of a stream, erosion may occur in several ways and may be identified as given below.

Erosion of streams in agricultural areas normally occurs as a result of one of the three factors:

- Change in stream flow,
- Water flowing over or through the stream bank and
- Discharge of concentrated runoff from other sources.

Streams are generally subject to wide fluctuations in both flow depth and velocity over a period of years due to normal seasonal changes in rainfall and large single-storm events. As the flow depths and velocities increase, the force of the water flowing against the stream bank removes soil particles from the banks, and in many cases erosion causes banks to slump and fall into the flowing water. A typical stream bank erosion is shown in Fig. 12.1. In extreme situations where high flows persist over long periods, banks may erode several feet annually. Rain falling on stream banks or runoff from adjacent fields that enters a stream by flowing over the stream banks can also erode soil from the banks, particularly if banks are inadequately protected. Finally, water discharged into a stream from tributary drainage systems (such as waterways or tile lines) can also erode stream banks, particularly if the water is discharged in an area where the bank is unstable and highly erodible. In many cases, moving the outlet to a point where the stream is less erodible or stabilizing the outlet area with rock can alleviate this problem.



Fig. 12.1. Stream Bank Erosion Showing Slump and Meandering.

Although a stream channel may appear to be stable, when viewed over a period of decades or centuries, most streams exhibit a tendency to adjust or shift location. In some instances, changes result from single event, such as a tree falling into a stream and deflecting the flow of the water. In other instances, these changes are due to differences in soil type and structure within the stream channel or are the result of erosion occurring from catastrophic storm events. Any straight stream channel will eventually erode some portions of each bank and begin to bend or meander. As the stream bends become longer and more sharply curved, more soil is eroded from one side of the channel and deposited on the other side of the channel.

12.2 Susceptible Area to Stream Bank Erosion

Catchments with little vegetation cover and steep gradients will often have high rates of water runoff that result in high-velocity stream flows. Stream straightening, dredging or realignment to accommodate roads or rail lines lead to increased stream impact and velocity, which in turn increase the energy applied to stream banks. The erosive impact of these high-velocity stream flows depends on the stability of the bank material. For instance, sand will erode more easily than gravel and silt will erode more easily than sand.

12.3 Process of Stream Bank Erosion

Erosion of stream or river banks through lateral (side) erosion and collapse often causes high sediment loads in creeks and rivers. The problem is often initiated by heavy rainfall in catchments with poor vegetation cover, causing excess runoff. The resultant high volume and velocity runoff will concentrate in the lower drainage lines or streams within the catchments. When the stress applied by these stream flows exceeds the resistance of the local soil material, stream bank erosion occurs. As the sediment load increases, fast-flowing streams grind and excavate their banks in the lower landscape. Later, the stream becomes overloaded or velocity is reduced and deposition of sediment takes place further downstream or finally in dams and reservoirs. Stream bank erosion is exacerbated by the lack of riparian zone vegetation and by direct stock access to streams.

The mechanisms of stream bank erosion can be classified into two main groups:

- Bank scour and
- Mass failure

In most of the cases bank instability can occur due to either scouring or mass failure being dominant. Bank scour is the direct removal of bank materials by the physical action of flowing water and is often dominant in smaller streams and the upper reaches of larger streams and rivers. Mass failure, which includes bank collapse and slumping, is where large chunks of bank material become unstable and topple into the stream or river in a single event. Mass failure is usually dominant in the lower reaches of large streams and often occurs in association with scouring of the lower banks. By looking carefully at the processes operating at a site it may be possible to narrow down the probable causes of instability.

12.4 Bank Scour

Bank scour is the direct removal of bank materials by the physical action of flowing water and the sediment it carries. Undercutting of the stream bank toe due to flowing water causing bank scour is shown in Fig. 12.2.



Fig. 12.2. Undercutting of the bank toe, a sign of bank scour.

As flow velocity increases, the erosive power of flowing water also increases and scour may occur. Increases in flow velocity can be the result of natural and/or human induced processes. Undercutting of the bank toe is an obvious sign of scour processes. Effective strategies for combating scour are generally aimed at reducing flow speed through re-vegetation and in some cases through strategic bank or channel works.

12.5 Mass Failure

Mass failure describes the various mechanisms of bank erosion that result in sections of the bank sliding or toppling into the stream. Mass failure is sometimes described as collapse or slumping (Fig. 12.3). Bare and near-vertical banks or areas of slumped bank materials are obvious signs of these processes. The causes of these types of failures are often difficult to determine but can include natural and/or human factors.



Fig. 12.3. Slumping is a Common Type of Mass Failure.

Collapse following undermining of the bank toe and slumping as a result of saturation after flooding are common examples of mass failure. Effective strategies for combating slumping or bank collapse are generally aimed at stabilizing the bank toe and restoring bank vegetation.

12.6 Impacts of Stream Bank Erosion

In addition to loss of productive land due to bank erosion, dramatic changes in the course of a river or creek often restrict access on properties. Subsequent deposition of soil causes problems on productive land downstream and sedimentation in reservoirs. Other problems include deterioration in water quality due to high sediment loads, loss of native aquatic

habitats, damage to public utilities (roads, bridges and dams) and maintenance costs associated with the prevention or control of erosion hazards.

12.7 Causes of Stream Bank Erosion

Stream bank erosion is a natural process that has over a period of time resulted in the formation of the productive floodplains and alluvial terraces common to the middle and lower reaches of many river systems.

Paradoxically, even stable river systems have some eroding banks. However, the rate at which erosion occurs in stable systems is generally much slower and of a smaller scale than that occurring in unstable systems.

Events like flooding can trigger dramatic and sudden changes in rivers and streams. However, land use and stream management can also trigger erosion responses. The responses can be complex, often resulting in accelerated rates of erosion and sometimes affecting stability for decades. Determining the cause of accelerated stream bank erosion is the first step in solving the problem.

- When a stream is straightened or widened, stream bank erosion increases.
- Accelerated stream bank erosion is a part of the process as the stream seeks to re-establish a stable size and pattern.
- Damaging or removing streamside vegetation to the point where it no longer provides for bank stability can cause a dramatic increase in bank erosion.
- A degrading stream bed results in higher and often unstable, eroding banks.
- When land use changes such as clearing of land for agriculture or development occur in a watershed, runoff increases. With this increase in runoff the stream channel will adjust to accommodate the additional flow, increasing stream bank erosion.

Addressing the problem of stream bank erosion requires an understanding of both stream dynamics and the management of streamside.

Stream bank erosion can also be accelerated by factors such as;

- Stream bed lowering or infill,
- Inundation of bank soils followed by rapid drops in flow after flooding,
- Saturation of banks from off-stream sources,
- Redirection and acceleration of flow around infrastructure, obstructions, debris or vegetation within the stream channel,
- Removal or disturbance of protective vegetation from stream banks due to trees falling from banks or by poorly managed stock grazing,
- Bank soil characteristics such as poor drainage or seams of readily erodible material within the bank profile,
- Wave action generated by wind,

- Excessive or inappropriate sand and gravel extraction and
- Intense rainfall events (e.g. cyclones).

12.8 Control Measures for Stream Bank Erosion

Many of the traditional methods for dealing with stream bank erosion have been expensive to install and maintain. Solutions such as rock riprap or gabions (wire baskets filled with rock) may solve the erosion problem, but implementation is possible at the expense of the habitat and the stream's natural beauty. Today there are some promising developments in the area of stream bank stabilization and stream restoration. Natural channel design principles look to nature for the blueprint to restore a stream to an appropriate dimension, pattern and profile. Soil bio-engineering practices, native material revetments and in-stream structures help to stabilize eroding banks. All these techniques combined together can be used to move a stream toward a healthy, naturally stable and self maintaining system. The possible control measures of stream bank erosion are discussed below.

12.8.1 Riprap

Riprap is a layer of large stones used to protect soil from erosion in areas of concentrated runoff as shown in Fig. 12.4 and Fig. 12.5. Riprap can also be used on slopes that are unstable because of seepage problems. When properly designed and installed, riprap can prevent the protected area from erosion. The steepness of the slope limits the applicability of riprap, because slopes steeper than 2:1 can cause riprap loss due to erosion and sliding. If used improperly, riprap can actually increase erosion. In addition, riprap can be more expensive than other stabilization options.

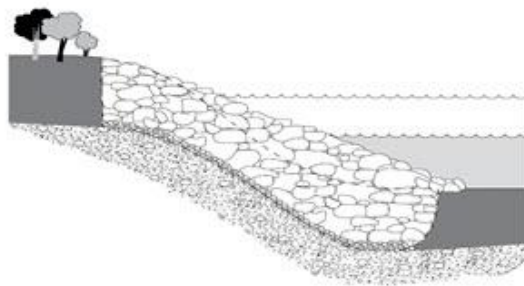

Fig. 12.4. Cross Section of a Riprap Revetment.



Fig. 12.5. Riprap for Protection of River Bank.

12.8.2 Gabions

Gabions are rectangular galvanized wire baskets filled with stones used as pervious, semi flexible building blocks for slope and channel stabilization (Fig. 12.6). Live rooting branches may be placed between the rock-filled baskets. Gabions are generally used where flow velocities are too high for riprap or the surface to be protected has a very steep slope.



Fig. 12.6. Use of Gabions for Protecting the Stream Bank from Erosion.

12.8.3 Soil Bio-engineering Practices

Bio-engineering uses plant materials in a structural way to reinforce and stabilize eroding stream banks. This technique relies on the use of dormant cuttings of willows, shrub dogwoods and other plants that root easily (Fig. 12.7). Bio-engineering practices range from simple live stakes to complex structures such as fabricated lifts incorporating erosion control blankets, plants and compacted soil.



Fig. 12.7. Bio-engineering Practices to Stabilize Eroding Banks Native Material

These practices use native materials, wood and stone to armor stream banks and deflect flow away from them. Low rock walls and log crib-walls can be used to armor the bank. Rootwads armor the bank and provide protection downstream by deflecting the flow away from the bank (Fig. 12.8). Rock and logs can be used to construct a variety of structures that stabilize the streambed and banks. Cross vanes are rock structures that stabilize the

streambed while aiding in stream bank stabilization. Rock or log vanes redirect stream flow away from the toe of the stream bank and help to stabilize the bank upstream and downstream from the structure (Fig. 12.9).



Fig. 12.8. Rootwads Armor to Protect the River Bank in-stream Structures.



Fig. 12.9. Rock Vanes for Protection of Stream Bank.



Lesson 13 River Training and Stream Bank Protection

13.1 Introduction

A river is a natural watercourse, usually of freshwater, flowing towards an ocean, a lake, a sea, or another river. In a few cases, a river simply flows into the ground or dries up completely before reaching another body of water. Small rivers may also be called by several other names, including stream, creek, brook, rivulet, run, tributary and rill. Rivers are the main source of water to satisfy domestic, municipal, irrigation, industrial and energy production demands.

Rivers are part of the hydrological cycle and the cycle is completed by flowing of storm water or melted snow water through defined channels, finally discharging unutilized water back into sea. Water within a river is generally collected from precipitation through a drainage basin from surface runoff and other sources such as groundwater recharge, springs, and the release of stored water in natural ice and snow packs (e.g., from glaciers). Potamology is the scientific study of rivers while limnology is the study of inland waters in general. Rivers carry tremendous amount of silt and sediment washed out from catchment area or eroded from river bed and banks. Before going into the details of river training and stream bank protection, it is important to learn about the types of rivers and their characteristics.

13.2 Types of Rivers

Rivers can be classified using their topological characteristics as well as based on their flood hydrograph as follows:

13.2.1 Based on the Topology of River Basin

13.2.1.1 Rivers of Hills (Upper Reach)

The perennial rivers fed from ice and snow packs (from glaciers) take off from mountains, and flow through hilly regions before traveling through the plains. These upper reaches of the river may be termed as Rivers of hills. These rivers further have two characteristics to be further classified as given below.

Incised or rocky rivers: In these rivers, the flow channel is formed due to erosion in highly steep reaches and with swift flow forming rapids (Fig. 13.1). In these rivers, river beds and banks are less susceptible to erosion. Sediment in this reach is often different from the river bed material as most of it comes from catchment due to denudation and soil erosion. In these rivers, the bed load can not be determined on the basis of usual bed load transportation formula derived on the basis of bed characteristics.



Fig. 13.1. Incised or Rocky Rivers.

Boulder River: River bed consists of boulders, gravels, shingles and alluvial sand deposits (Fig. 13.2). These rivers flow through wide shallow beds and interlaced channels, and develops straight course. During floods, boulders, gravels, shingles are transported, get deposited downstream and form heaps when flood subsides. Normal water unable to shift these heaps goes around them, often attack the banks and consequently widen the bed.



Fig. 13.2. Boulder River.

13.2.1.2 Rivers in Alluvial Plains (Rivers in Flood Plains - Lower Reach)

After the boulder stage, a river enters the alluvial plains. The bed and banks are now made up of sand and silt. The bed slope and the velocity of flow in the river are much smaller than those of the boulder rivers. The cross-section of the river is decided by the sediment load and the erodibility of the bed and banks of the river. The sediment transported by such rivers is predominantly of the same type as the material forming the channel bed. During high floods, these rivers inundate very large areas and cause considerable damage to life, property, and crops. Such rivers are also called alluvial rivers.

These rivers, i.e. rivers in flood plain, follow zig-gag path- called meandering. Rivers meander freely, generating huge amount of sediment, and carry sediment similar to bed

material. Soil gets eroded constantly from outer edge of the bend and gets deposited either on the inner edge or between two successive bends forming a bar. Once a straight moving river slightly deviates from its axis, the unbalance created goes on multiplying with constant erosion from the concave side and deposition on the convex side (Fig. 13.3). If these erosion processes are unchecked, the process continues, resulting in the formation of large meanders. Rivers in flood plains can be further classified as: aggrading or accreting type, degrading type, stable type, braided type, and deltaic type rivers.

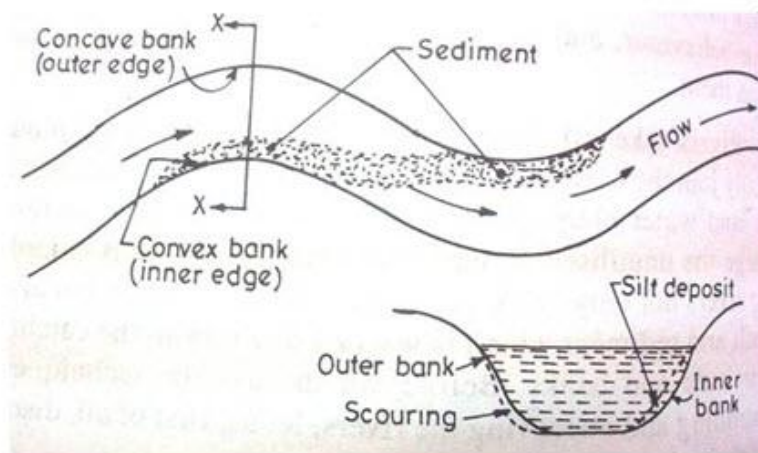

Fig. 13.3. Rivers in Alluvial Plains.

Aggrading Rivers: These are silting river, collecting sediment and increasing their bed slope (building up of slope). The causes of silting could be heavy sediment load due to construction of obstruction across the river (dam and weir), sudden intrusion of sediment from tributary, etc. These rivers have straight and wide reaches with shoal in the middle.

Degrading Rivers: In these rivers, the bed is constantly eroded /scoured to reduce the land slope. The elevated bed soil is eroded and is transported by the flowing water. Under these conditions, the river bed slope is reduced to achieve more stable bed with reduced slope. These rivers are generally found below a dam or a weir or a barrage.

Stable Rivers: When the alignment of a river channel, river slope, and river regime are relatively stable and show little variation from year to year except that the river may migrate within its permanent banks, the river is said to be stable. However, changes in bed and plan-forms of a stable river do take place, but these are small.

Braided Rivers: River flows in two or more channels around alluvial island, developed after local deposition of coarser material (Fig. 13.4).

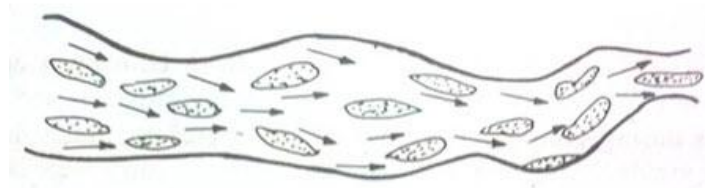

Fig. 13.4. Braided river.

Deltaic Rivers: Rivers which before joining the sea get divided into branches, due to very flat bed slopes resulting in shoal formation and braiding of the channel, forming delta are called deltaic rivers (Fig. 13.5). The delta river indicates a stage, rather than a type of river.

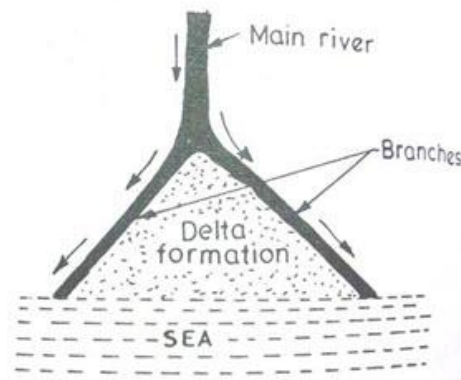

Fig. 13.5. Deltaic rivers. (Source: Asawa, 1993)

Tidal Rivers: After passing through the alluvial plain, the tail reaches of the rivers adjoining the oceans are affected by ocean tides. Ocean water enters into the river during the flood tide and moves back during ebb tide. Thus the river undergoes periodic rise and fall in its water level which creates water flush in the lower/last portion of the river. The distance affected due to this sudden water flush; causing disturbances due to water and sediments; depends on configuration of river, tidal range, freshet discharge etc.

13.2.2 Based on Flood Hydrograph

Flashy Rivers

In case of flashy rivers, the river stage rises and falls in a very short period of a day or two due to the steep flood hydrograph. A small flow may, however, continue for some time.

Virgin Rivers

In arid regions, waters of some rivers may get completely lost due to evaporation and percolation before meeting another water body. Such rivers become completely dry much before they join another river or sea, and are called virgin rivers.

13.3 Objectives of River Training

River training is an age-old practice resulting in incessant development and application of human ingenuity to correct vagaries of the rivers. It requires deep and precise study of river mechanism and behaviour discussed heretofore. River training has assumed considerable significance in India due to huge annual recurring damage caused by the floods; 80 per cent of which accounts for loss of crops. River training, in its broad aspects, covers all engineering works constructed on a river to guide and confine the flow to the river channel, and to control and regulate the river bed configuration for effective and safe movement of floods and river sediments. In essence, river training envisages training and stabilizing a river within a suitable waterway and along a certain alignment for a variety of purposes. River training works involve large outlays and it is essential to select the type of the training work and materials of construction so as to make optimum utilization of funds, and effective as well as economical utilization of the available construction materials.

The various objectives of river training are:

1. To guide the axis of flow at ordinary and low stages and safe passage of floods without overtopping the banks,

2. To protect the banks from erosion and generally improve their alignment by stabilizing the river channel,
3. To train the river flow along a safe course, thereby avoiding damage by flooding or erosion of valuable lands, habitations, crops, factories, etc.,
4. To prevent outflanking of a bridge, barrage or weir by directing the flow in a defined stretch of the river,
5. To prevent river from changing its course,
6. To confine a too wide river channel due to swinging from side to side and to reclaim the land from river bed,
7. To check certain devastations like flash torrents,
8. To trap bed load in areas of superfluous width,
9. To transport efficiently bed load and suspended sediment load,
10. To provide sufficient depth of flow for safe navigation,
11. To establish channel boundaries where braiding has been created too wide a section divided into small channels separated by islands, and
12. To correct disorderly banks or flow conditions.

13.4 Methods of River Training

The following types of river training works are generally adopted:

1. Guide bunds;
2. Spurs (Groynes);
3. Marginal bunds;
4. Closure bunds; and
5. Assisted cut offs.

13.4.1 Guide Bunds

The necessity of guide bunds is in confining and guiding the river flow through the structure without causing damage to it and its approaches. They also prevent the out flanking of the structure. The shape and design features of guide bunds provide necessary guidance to the flow. The guide bund can either be divergent upstream or parallel. In the case of divergent guide bund, there is possibility of formation of a shoal at the center. Parallel guide bunds minimize obliquity and separation of flow along the flanks. According to geometrical shape, the guide bunds may be straight or elliptical. In the case of certain type of alluvial rivers with sandy bed and meandering pattern, elliptical shape of guide bund appears to be preferable to minimize obliquity and separation of flow.

Normally the upstream shank of the guide bund is between 1.0 to 1.5 times the length of the bridge, while the downstream shank is between 0.2 to 0.4 times the length of the bridge. The

tail bund on the downstream side is provided to afford an easy exit to the water and to prevent formation of vertical whirlpools or rollers which give rise to scour. These tail bunds are also curved at their ends and should be properly protected. The slope in the rear of the guide bund need not necessarily be provided with pitching and may be protected by planting suitable grass or shrubs.

Maintenance:

- Substantial reserve of pitching stone should be maintained on the guide bund for use during emergency. This should be stacked at the top of the guide bund.
- The track on the guide bund, where provided, should be maintained in a satisfactory condition. The track should be inspected soon after the monsoon every year and carry out necessary repairs well before the next monsoon.
- Disturbance of pitching stone on the slope indicates dangerous condition and additional stones should be placed in position immediately as necessary.

13.4.2 Spurs (Groynes)

A spur (also called groyne) is a structure constructed transverse to the river flow and is projected from the bank into the river. In practice, there are two types of spurs- either 'Permeable' or 'Impermeable'. Permeable spurs are constructed by driving wooden bullies or bamboos, filled in with brush wood, with sarkanda mattresses or other suitable material. These are helpful in causing quick siltation due to damping of velocity. They are useful when concentration of suspended sediment load is heavy as they allow the water to pass through them easily. Impermeable spurs are made of solid core, constructed of stones or earth and stones with exposed faces protected by pitching. These spurs can withstand severe attacks as compared to the permeable spurs.

Based on the working characteristics, spurs may also be classified as (a) repelling (deflecting), (b) attracting and (c) neutral (sedimenting) spurs as shown in Fig. 13.6. Repelling or deflecting spurs are those which incline upstream at an angle of 60° to 70° to the river course and deflect the current towards the opposite bank. They cause silting in still water on the upstream pocket. Attracting spurs incline downstream and allow deep channel flow continuously along their noses. They cause scour just on the downstream side of the head due to turbulence. The river flow is attracted towards the spur. Neutral or sedimenting spurs are those which are built at right angles to the bank to keep the stream in a particular position and promote silting between the spurs. They have practically no effect on the diversion of the current and are mostly used for training of rivers for navigational purposes.

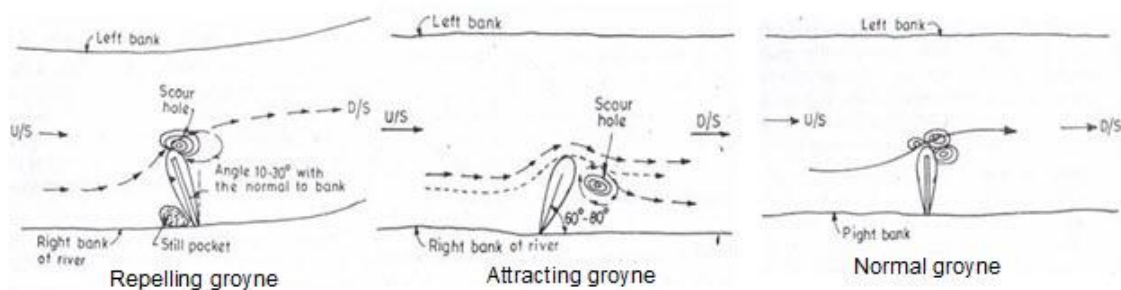

Fig. 13.6. Gryones (Repelling, Attracting & Normal) Types.

Spurs are also classified as full height spurs and part height spurs. Where top level is higher than the highest flow level (HFL) of the stream, it is called a full height spur. All these spurs are generally extended into the stream with straight head end. However, spurs are also constructed extending into the stream with a 'T' head or hockey stick shaped head (Fig. 13.7), properly designed to hold the river flow at a distance. A series of such spurs/groynes correctly positioned can hold the river at a position away from the point intended to be protected. The edge of the 'T' head should be curved somewhat in the manner of a guide bund to avoid swirls. The banks get protected from certain distance upstream and downstream of the groynes. The maintenance procedures specified for guide bunds apply equally to spurs/groynes also.

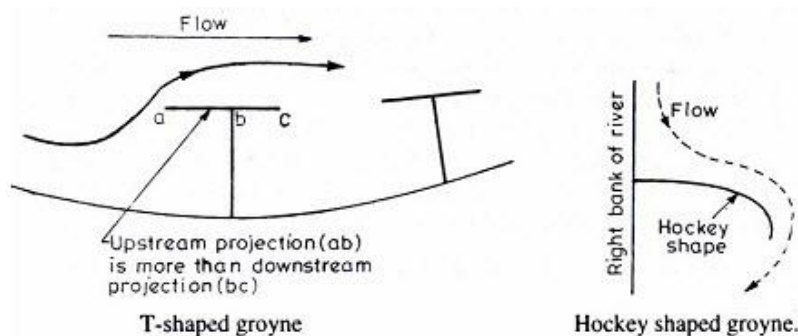

Fig. 13.7. 'T' Head and Hockey Stick Shaped Head Groynes.

13.4.3 Marginal Bunds

Marginal bunds are provided to contain the spread of the river when the river in flood spills over its banks upstream of the bridge site over wide area and likely to spill in the neighbouring water courses or cause other damages. The marginal bund should normally be built well away from the active area of the river. The slope should be well protected by turfing. Where a marginal bund has to be built in the active area of the river, it should be protected with pitching and apron. The earth for the construction of marginal bund should preferably be obtained from the river side. The upper end of the marginal bund should be anchored into high ground well above HFL. Marginal bunds should be inspected every year along with the annual bridge inspection and necessary repairs should be carried out before the onset of monsoon. Cattle crossing and rodent holes across the marginal bund should be specially watched and protected.

13.4.4 Closure Bunds

Sometimes it may be necessary to entirely block one or more channels of the river in order to prevent the discharge of such channels developing into a main river channel after the construction of the bridge. This is done by providing a closure bund. The bund is designed as an earthen dam. The same is generally constructed at some distance from the railway line. Special care should be exercised to guard it against its failure. It should be inspected every year after the monsoon and necessary repairs should be carried out.

13.4.5 Assisted Cutoffs

Sometimes when very heavy meandering develops near bridges and there is a danger of its encroaching too heavily into the still water area or otherwise dangerously approaching the embankment, it becomes necessary to dig a cut-off channel which will ultimately develop and help in the diversion of water through it. To make it economical, a pilot channel cut is

usually made when there is low flow in the river and full development of the channel takes place during the flood. This cut off channel should preferably have (i) at least three times the river's straight regime slope, and (ii) the upstream end should take off from where the bed load of main channel has less than the average amount of coarse material i.e. from the active part of the channel where the velocity is more. The entrance to the pilot cut should be bell shaped to facilitate entry of water. The chord loop ratio should normally be greater than 1 to 5 if a successful channel is to develop. Cut off should be planned with care taking all relevant factors into account.

13.5 Design of Spurs

The design of spurs for river training and protection mainly consists of identifying the number of spurs required to protect a certain stretch of the river length depending upon the size (effective length) of the spur. The selection of the length of spur depends upon the position of the existing bank line and the designed or expected bank line for the trained river. Too long groynes on easily erodible rivers make the protection susceptible to damage and failure. Along with the length of the spurs, spacing between the successive spurs is also important. Spacing between the spurs depends on the effective length and the types of banks to be protected. For an example, convex bank sides are protected with larger spur spacing whereas smaller spacing is suggested for concave banks. Another aspect in designing the spur spacing is dependent on the width of river. For wider river, larger spur spacing is preferred. Design of the spurs spacing is given below.

The spacing between the spurs or groynes generally bears a definite ratio to their length (l) exposed to the stream. The common practice is to keep the spacing (S) at about 7 to 7.5 times the effective length- h (vertical length from river bank) so as to effectively protect the bank. The total number of spurs required to protect the river bank can be calculated as:

$$N = \frac{L}{S} + 1 \quad (13.1)$$

where,

N = number of spurs and

$S = 7h$, where h is the vertical projection of spur exposed in the river stream.

If θ is the angle of inclination of spur from vertical, then

$$h = l \cos \theta \quad (13.2)$$

where, l = length of spur exposed to the stream.

In placing spurs, care should be taken to see that they are never constructed at a point where severe bank erosion is taking place but should be placed at some distance upstream. One or two extra spurs should be placed upstream side for effective protection of eroding stream bank and safely guiding the stream.

Solved Problems: Spur Design

1. Find out the number of spurs to control one side of the stream bank of 150 m length. The average flood flow is $5000 \text{ m}^3/\text{sec}$. It is given that the length of spur is 10 m and angle of projection is 30° from the vertical.

Solution:

Total length of eroded bank, $L = 150 \text{ m}$

Projection angle from vertical, $\theta = 30^\circ$

Total length of spur = 10 m

We have,

Length of the spur exposed to the river- l (assume that one third of total length is embedded into the bank)

$$l = 10 \times \frac{2}{3} = 6.67 \text{ m}$$

Vertical projection of spur exposed in the river stream-

$$h = l \cos\theta = 6.67 \times \cos 30^\circ = 5.78 \text{ m}$$

Let us assume the spacing of spur (S) = 7 h

$$= 7 \times 5.78 = 40.4 \text{ m}$$

Thus number of spurs required to protect eroded downstream (using equation 13.1)

$$N = (150/40.4) + 1$$

$$= 4.71 = 5 \text{ spurs}$$

Assuming that 2 spurs are provided towards the upstream face additionally, total number of spurs required = $5 + 2 = 7$ spurs.



Module 3: Wind Erosion, Estimation and Control

Lesson 14 Wind Erosion and Its Estimation

14.1 Wind Erosion

Wind erosion is a serious environmental problem. It is in no way less severe than water erosion. High velocity winds strike the bare lands (having no cover), with increasing force. Fine, loose and light soil particles blown from the land surface are taken miles and miles away and thereby, causing a great damage to the crop productivity. It is a common phenomenon occurring mostly in flat, bare areas; dry, sandy soils; or anywhere the soil is loose, dry and finely granulated and where high velocity wind blows. Wind erosion, in India, is commonly observed in arid and semi-arid areas where the precipitation is inadequate, e.g. Rajasthan and some parts of Gujarat, Punjab and Haryana.

Wind erosion damages land and natural vegetation by removing soil from one place and depositing it at another location. It causes soil loss, dryness and deterioration of soil structure, nutrient and productivity losses and air pollution. Smaller particles of soil are more subject to movement by wind as silt, clay and organic matter are removed from the surface soil by strong wind, leaving the coarse, lesser productive material behind. Suspended dust and dirt are inevitably deposited over everything. It blows on and inside homes, covers roads and highways, and smothers crops. Sediment transport and deposition are significant factors in the geological changes which occur on the land around us and over long periods of time are important in the soil formation process. Most serious damage caused by wind erosion is the change in soil texture. Damage caused by wind erosion is demonstrated in Fig.14.1.



Fig. 14.1. An Illustration of Wind Erosion.

14.2 Factors Affecting Wind Erosion

Climate, soil and vegetation are the major factors affecting wind erosion at any particular location. The climatic factors that affect the wind erosion are the characteristics of wind itself (velocity and direction) in addition to the precipitation, humidity and temperature. Soil

moisture conditions, texture, structure, density of particles, organic matter content are the soil characteristics that influence erosion by wind. Soil movement is initiated as a result of wind forces exerted against the surface of the ground. For each specific soil type and surface condition there is a minimum velocity required to move soil particles. This is called the threshold velocity. Once this velocity is reached, the quantity of soil moved is dependent upon the particle size, the cloddiness of particles, and wind velocity itself. Surface features like vegetation or other artificial cover (mulching etc) have the protective effect on wind erosion problem as surface cover increases the roughness over the land surface and thus reduces the erosive wind force on the land surface.

14.3 Mechanics of Wind Erosion

The overall occurrence of wind erosion could be described in three distinct phases. These are:

1. Initiation of Movement
2. Transportation
3. Deposition.

Movement of soil particles is caused by wind forces exerted against or parallel to the ground surface. The erosive wind is turbulent at all heights except very close to the surface. The lowest velocity occurs close to the ground and increases in proportion to the logarithm of the height above the surface. Soil particles or other projections on the surface absorb most of the force exerted by the wind on the surface. However, if the soil particles are lighter and loose, wind may lift them from the surface in the initiation process. A minimum threshold velocity (wind) is required to initiate the movement of soil particles. Thus, the threshold velocity is the minimum wind velocity needed to initiate the movement of soil particles. The magnitude of the threshold velocity is not fixed for all places and conditions but it varies with the soil conditions and nature of the ground surface. For example, for the most erodible soils of particle size about 0.1 mm; the required threshold velocity is 16 km/h at a height of 30 cm above the ground.

14.3.1 Initiation of Movement: The soil particles are first detached from their place by the impact and cutting action of wind. These detached particles are then ready for movement by the wind forces. After this initiation of movement, soil particles are moved or transported by distinct mechanisms.

14.3.2 Transportation: The transportation of the soil particles are of three distinct types and occur depending upon size of the soil particles. Suspension, saltation, and surface creep are the three types of soil movement or transport which occur during wind erosion. While soil can be blown away at virtually any height, the majority (over 93%) of soil movement/transportation takes place at or within one meter height from land surface. These transportation mechanisms of soil particles due to wind are shown in Fig. 14.2.

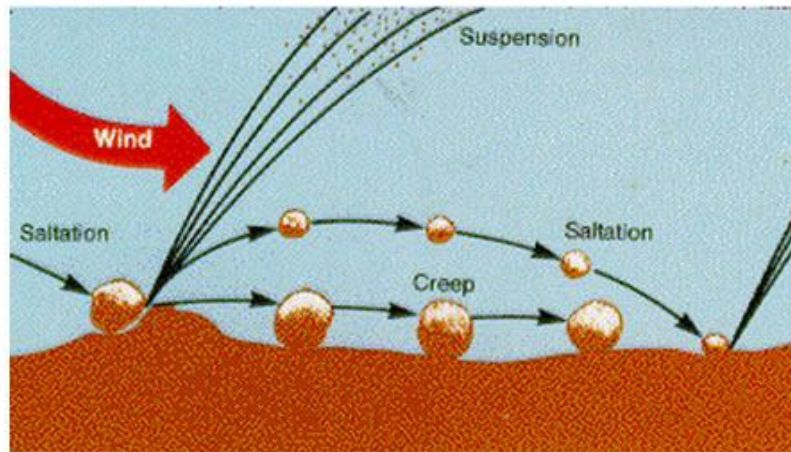

Fig. 14.2. Mechanics of Wind Erosion.

14.3.3 Suspension: It occurs when very fine dirt and dust particles are lifted into the atmosphere. They can be thrown into the air through impact with other particles or by the wind itself. These particles can be carried very high and be transported over very long distances in the atmosphere by the winds. Soil moved by suspension is the most spectacular and easiest to recognize among the three forms of movement. The soil particles of less than 0.1 mm size are subjected to suspension and around 3 to 40 % of soil weights are carried by the suspension method of soil transport under the wind erosion.

14.3.4 Saltation: The major fraction of soil moved by the wind is through the process of saltation. Saltation movement is caused by the pressure of the wind on soil particles as well as by the collision of a particle with other particles. Soil particles (0.1 to 0.5 mm) move in a series of bounces and/or jumps. Fine soil particles are lifted into the air by the wind and drift horizontally across the surface increasing in velocity as they move. Soil particles moved in the process of saltation can cause severe damage to the soil surface and vegetation. They travel approximately four times longer in distance than in height. When they strike the surface again they either bounce back into the air or knock other soil particles from the soil mass into the air. Depending on soil type, about 50 to 75% of the total weight of soil is carried in saltation. The height of the jump varies with the size and density of the soil particles, the roughness of the soil surface, and the velocity of the wind.

14.3.5 Surface Creep: The large particles which are too heavy to be lifted into the air are moved through a process called surface creep. In this process, the particles are rolled across the surface after coming into contact with the soil particles in saltation. In this process the largest of the erosive particles having diameters between 0.5 to 2 mm are transported and around 5 to 25% of the total soil weights are carried in this fashion. Overall, the mass of soil moved by wind is influenced primarily by particle size, gradation of particles, wind velocity and the distance along the eroding area. Winds being variable in velocity and direction produce eddies and cross-currents that lift and transport soil. The amount of soil moved/transported depends on the median particles (soil) diameter and the difference in threshold and actual wind velocity. The mass of soil moved can be related to the influencing parameters by the following equation:

$$\text{Quantity of soil moved} \propto (V - V^{\text{th}})^3 / D^{0.5}$$

where V = wind velocity, V^{th} = threshold velocity, and D = particle diameter.

14.3.6 Deposition: Deposition of soil particles occurs when the gravitational force is greater than the forces holding the particle in the air. This generally happens when there is a decrease in the wind velocity caused by vegetative or other physical barriers like ditches or benches. Raindrops may also take dust out of air.

14.4 Estimation of Soil Loss Due to Wind Erosion

An equation in the form of universal soil loss equation has been developed and can be used for estimating soil loss by wind. However, the evaluation of the constants in the equation for wind erosion is comparatively difficult than the universal soil loss equation. The equation is of the form,

$$E = IRKFCWDB \quad (14.1)$$

Where, E is soil loss by wind erosion, I is soil cloddiness factor, R is surface cover factor, K is surface roughness factor, F is soil textural class factor, C is factor representing local wind condition, D is wind direction factor, and B is wind barrier factor, W is field width factor.

Another model of wind erosion estimation used in USA is as follows:

$$E = f(I, K, C, L, V) \quad (14.2)$$

Where, E is estimated average annual soil loss (t/ha/yr), I is soil erodibility index (t/ha-yr), K is ridge roughness factor, C is climate factor, L is unsheltered length of eroding field (m), and V is vegetative cover factor.

The soil erodibility index (I) can be estimated as given below

$$I = 525(2.718)^{-0.05F} \quad (14.3)$$

Where, F is % of dry soil fraction greater than 0.84 mm, K is ridge roughness factor; a measure of ridges made by tillage implements on wind erosion and can be estimated as given below

$$K_r = \frac{0.16h^2}{d} \quad (14.4)$$

Where, K_r is ridge roughness, h is ridge height in mm, d is ridge spacing in mm, and K can be estimated as a function of ridge roughness.

$$K = 0.35 + \frac{12}{(K_r + 18)} + (6.2 * 10^{-6} K_r^2) \quad (14.5)$$

The climatic factor (C) depends on wind velocity and soil surface moisture. The mean wind velocity profile above the soil surface is estimated as given below.

$$U_z = \left(\frac{U_*}{k} \right) \ln \left(\frac{z-d}{z_0} \right) \quad (14.6)$$

$$\text{Where, } U_* = \text{Frictional Velocity} = \frac{\tau_0 (\text{shear stress at boundary})}{\rho (\text{air density, } 1.2 \text{ kg/m}^3)} \quad (14.7)$$

$k = \text{vonKarman's constant} = 0.4 (\text{usually taken})$

$Z_0 = \text{a roughness parameter}$

$d = \text{effective surface roughness height}$

$\log d = \log h - 0.15$

$\log z_0 = \log h - 0.09$

$c = \text{crop height}$

Solved Problem:

Find out the wind velocity at 10 and 15 m height from ground surface over a wheat cropped field of plants height 1.3 m and friction velocity of 6 m/s.

Solution: The mean wind velocity above the soil surface is estimated as-

$$U_z = \left(\frac{U_*}{k} \right) \ln \left(\frac{z-d}{z_0} \right)$$

Given: frictional velocity (U_z) = 6 m/s

Plants height of wheat cropped field = 1.3 m (h)

$z = 10$ and 15 m,

$\log d = \log h - 0.15$

$\log z_0 = \log h - 0.09$

Estimating d and z_0

$\log d = \log(1.3) - 0.15 = -0.03606$

$d = 0.92033$ m

$\log z_0 = \log(1.3) - 0.09 = -0.023943$

$z_0 = 1.05668$ m

Now: $U_{10} = 32.26359$ m/s, and $U_{15} = 38.84401$ m/s.

Lesson: 15 Wind Erosion Control Measures

Wind erosion is the process of detachment, transportation and deposition of soil particles by the action of wind. It occurs in all parts of the world and is a cause of serious soil deterioration. In India, Rajasthan has severe wind erosion problem. A large part of area the state is affected by sand dune formation. Some parts of coastal areas also have such problems. It most commonly occurs in the regions where soil is loose, finely divided and dry, soil surface is smooth and bare, and where wind is strong to detach the soil particles from the surface.

15.1 Wind Erosion Control

A suitable surface soil texture is the best key to wind erosion protection. Properly managed crop residues, carefully timed soil tillage, and accurately placed crop strips and crop barriers can all effectively reduce wind erosion. Proper land use and adaptation of adequate moisture conservation practices are the main tools which help in wind erosion control. In arid and semiarid regions where serious problem of wind erosion is common, several cultural methods can help to reduce the wind erosion. In the absence of crop residue, soil roughness or soil moisture can reduce the wind erosion effectively.

Three basic methods can be used to control wind erosion:

- Maintain Vegetative Cover (Vegetative Measures)
- Roughen the Soil Surface by Tillage Practices (Tillage Practices or may be called Tillage Measures)
- Mechanical or Structural Measures (Mechanical Measures)

There is no single recipe for erosion control as many factors affect the outcome. However, with an understanding of how soil is eroded, strategies can be devised to minimize erosion.

15.2 Vegetative Measures

Vegetative measures can be used to roughen the whole surface and prevent any soil movement. The aim is to keep the soil rough and ridged to either prevent any movement initially or to quickly trap bouncing soil particles in the depressions of the rough surface. A cover crop with sufficient growth will provide soil erosion protection during the cropping season. It is one of the most effective and economical means to reduce the effect of wind on the soil. It not only retards the velocity near the ground surface but also holds the soil against tractive force of wind thereby helping in reduction of soil erosion.

From the basic concept, the velocity of wind decreases near the ground surface because of the resistance offered by the vegetation. The variation in wind velocity with respect to height above the land surface increases exponentially (chapter 14).

Vegetative measures can be of two types:

1. Temporary Measures
2. Permanent Measures

The use of these measures depends upon the severity of erosion.

15.3 Tillage Practices

The tillage practices, such as ploughing are importantly adopted for controlling wind erosion. These practices should be carried out before the start of wind erosion. Ploughing before the rainfall helps in moisture conservation. Ploughing, especially with a disc plough is also helpful in development of rough soil surface which in turn reduces the impact of erosive wind velocity. Both the above effects are helpful in controlling the wind erosion.

Surface roughening should only be considered when there is insufficient (less than 50%) vegetation cover to protect the soil surface or when the soil type will produce sufficient clods to protect the surface. Roughening can be used in both crop and pasture areas. Surface roughening alone is inadequate for sandy soils because they produce few clods. Tillage ridges, about 100 mm high, should be used to cover the entire area prone to erosion. Ridges that are lower than 100 mm get quickly filled with sand, whilst the crest of the ridge that is higher than 100 mm tends to erode very quickly.

The common tillage practices used for wind erosion control are as under:

- Primary and Secondary Tillage
- Use of Crop Residues
- Strip Cropping

15.4 Mechanical Measures

This method consists of some mechanical obstacles, constructed across the prevailing wind, to reduce the impact of blowing wind on the soil surface. These obstacles may be fences, walls, stone packing etc., either in the nature of semi-permeable or permeable barriers. The semi-permeable barriers are most effective, because they create diffusion and eddying effects on their downstream face. Terraces and bunds also obstruct the wind velocity and control the wind erosion to some extent. Generally, in practice two types of mechanical measures are adopted to control the wind erosion; i) wind breaks and ii) shelter belts.

15.4.1 Wind Breaks

This is a permanent vegetative measure which helps in the reduction of wind erosion. It is most effective vegetative measure used for controlling severe wind erosion. The term wind break is defined as any type of barrier either mechanical or vegetative used for protecting the areas like building apartments, orchards or farmsteads etc. from blowing winds. The wind break acts as fencing wall around the affected areas, normally constructed by one row or maximum up to two rows across the prevailing wind direction.

A further use for "windbreaks" or "wind fences" is for reducing wind speeds over erodible areas such as open fields, industrial stockpiles, and dusty industrial operations. As erosion is proportional to the cube of wind speed, a reduction in wind speed by 1/2 (for example) will

reduce erosion by over 80%. The largest one of these windbreaks is located in *Oman* (28 m high by 3.5 km long) and was created by Mike Robinson from Weather Solve Structures.

15.4.2 Shelter Belts

A shelterbelt is a longer barrier than the wind break, is installed by using more than two rows, usually at right angle to the direction of prevailing winds. The rows of belt can be developed by using shrubs and trees. It is mainly used for the conservation of soil moisture and for the protection of field crops, against severe wind erosion.

Shelterbelt is more effective for reducing the impact of wind movement than the wind break. Apart from controlling wind erosion, it provides fuel, reduces evaporation and protects the orchard from hot and cold winds.

Woodruff and Zingg (1952) developed the following relationship between the distance of full protection (d) and the height (h) of wind break or shelter belt.

$$d = 17h \left(\frac{v_m}{v} \right) \cos \theta$$

Where, d is the distance of full protection (m), h is the height of the wind barrier (wind break or shelter belt) (m), v_m is the minimum wind velocity at 15 m height required to move the most erodible soil fraction (m/s), v is the actual velocity at 15 m height, and θ is the angle of deviation of prevailing wind direction from the perpendicular to the wind barrier.

This relationship (equation) is valid only for wind velocities below 18 m/s. This equation may also be adapted for estimating the width of strips by using the crop height in the adjoining strip in the equation. The value of v_m for a bare smooth surface after erosion has been initiated and before wetting by rainfall and subsequent surface crusting is about 9.6 m/s.

15.5 Sand Dunes Stabilization

A 'Dune' is derived from English word 'Dun' means hilly topographical feature. Therefore a sand dune is a mount, hill or ridge of sand that lies behind the part of the beach affected by tides. They are formed over many years when windblown sand is trapped by beach grass or other stationary objects. Dune grasses anchor the dunes with their roots, holding them temporarily in place, while their leaves trap sand promoting dune expansion. Without vegetation, wind and waves regularly change the form and location of dunes. Dunes are not permanent structures.

Sand dunes provide sand storage and supply for adjacent beaches. They also protect inland areas from storm surges, hurricanes, flood-water, and wind and wave action that can damage property. Sand dunes support an array of organisms by providing nesting habitat for coastal bird species including migratory birds. Sand dunes are also habitat for coastal plants. For example: 'The Seabrook dunes' are home to 141 species of plants, including nine rare, threatened and endangered species.

There are three essential prerequisites for sand dune formation:

- (1) An abundant supply of loose sand in a region generally devoid of vegetation (such as an ancient lake bed or river delta);
- (2) A wind energy source sufficient to move the sand grains.
- (3) A topography whereby the sand particles lose their momentum and settle down.

The best method by which the sand dunes can be stabilized is to reduce the erosive velocity. Therefore, various methods which are employed for sand dune stabilization are based on the principle to dissipate the erosive power of wind, so that the detachment and transportation of soil particles cannot take place. Some methods employed for sand dune stabilization are:

- Vegetation/Vegetative Measures
- Mechanical Measures
- Straw (Checkerboard and Bales)/Mats and Netting
- Chemical Spray

15.5.1 Vegetative Measures

This method is most common and preferred worldwide for sand dune stabilization. It is a most effective, least expensive, aesthetically pleasing method which mimics a natural system with self-repairing provision. However, it has some disadvantages as the plant establishment phase is critical, it needs irrigation and maintenance until self-sustaining system is developed. Most common practices adopted under this are:

15.5.1.1 Raising of Micro Wind Breaks

It is preferred in those areas where wind velocity is intensive and rainfall is less than 300 mm per year. The raising of wind break should be completed before the onset of monsoon. Twigs or brush woods are inserted into the soil parallel to one another at about 5 m spacing. The spacing depends on the intensity of erosive wind velocity, if the velocity is more spacing is less and vice versa. The fencing of dunes using brush woods reduces evaporation loss and also enriches the humus content in the soil.

15.5.1.2 Retreating the Dunes

In this, the micro wind breaks are treated again by planting tree saplings and grasses in the space left. The grasses grown in the intersection of plants of wind break reduce the soil loss from the dune surface significantly.

15.5.2 Mechanical Measures

Wind breaks, shelterbelts, stone pitching, fences etc., either manmade or natural barriers are helpful to reduce the wind velocity thereby favoring the stabilization of sand dunes.

15.5.3 Straw Checker Boards

This technique of sand dunes stabilization is extensively used in China since 1950's. Wheat or rice straw or reeds (50 – 60 cm in length) are placed vertically to form the sides of the checkerboard, which are typically 10 to 20 cm high. Optimum grid size of checker ranges

from 1 × 1 m to 2 × 2 m, depending on local wind and sand transport conditions. Smaller grids are used in areas where winds are stronger.

15.5.4 Chemical Spray

Sometimes crude oils are used for the successful stabilization of sand dune. The oil is heated to 50 °C and sprayed on the dune at the rate of 4 m³/ha. It is a temporary measure, lasting only for 3-4 years and during those years, it is expected that the vegetation growth will take place in that area. This method is costly and suitable only for small areas.

Solved Problems:

1. Determine the spacing between windbreaks that are 15 m high. 5 year return period wind velocity at 15 m height is 15.6 m/s and the wind direction deviates 10° from the perpendicular to the field strip. Assume a smooth, bare soil surface and a fully protected field.

Solution:

Given: $h = 15 \text{ m}$

$$V = 15.6 \text{ m/s}$$

$$\theta = 10^\circ$$

$$V_m = 9.6 \text{ m/s (for smooth, bare soil surface)}$$

Spacing = distance of full protection by a windbreak,

Therefore,

$$\begin{aligned} d &= 17h \left(\frac{V_m}{V} \right) \cos \theta = 17 \times 15 \left(\frac{9.6}{15.6} \right) \cos 10^\circ \\ &= 154.54 \text{ m} \end{aligned}$$

Thus, the spacing between windbreaks = 154.54 m.

2. Determine the full protection strip width for field strip cropping if the crop in the adjacent strip is wheat, 0.9 m tall, and the wind velocity at 15 m height is 8.9 m/sec at 90° with the field strip.

Solution:

Given: $h = 0.9 \text{ m}$

$$v = 8.9 \text{ m/s}$$

$$\theta = 0^\circ$$

Assuming $v_m = 8.9 \text{ m/sec}$ (Because theoretical $v_m = 9.6 \text{ m/sec}$ which is greater than the prevailing wind velocity). Since the field conditions are not specified taking $v_m = v$.

Full protection width-

$$d = 17h \left(\frac{V_m}{V} \right) \cos \theta = 17 \times 0.9 \left(\frac{8.9}{8.9} \right) \cos \theta$$
$$= 15.3 \text{ m}$$

Thus, strip width = 15.30 m.



AGRIMOON.COM

All About Agriculture...

Module 4: Soil Loss- Sediment Yield Estimation

Lesson 16 Soil Loss/Sediment Yield Estimation

For estimation of soil loss various methods were developed by different scientists over a period of time. Some of the most useful methods are presented in this chapter.

16.1 Estimation of Soil Loss

The control of erosion is essential to maintain the productivity of soil and to improve or maintain downstream water quality. The reduction of soil erosion to tolerable limits necessitates the adoption of properly planned cropping practices and soil conservation measures. Several methods exist for the measurement of soil loss from different land units. These include the measurements from runoff plots of various sizes for each single land type and land use, small unit source watersheds, and large watersheds of mixed land use. However, to estimate soil erosion, empirical and process based models (equations) are used. Universal Soil Loss Equation (USLE) is an empirical equation. It estimates the average annual mass of soil loss per unit area as a function of most of the major factors affecting sheet and rill erosions. Estimating soil loss is considerably more difficult than estimating runoff as there are many variables, both natural such as soil and rainfall and man-made such as adopted management practices. The soil loss considerably depends on the type of erosion. As a result, models, whether empirical or process-based, are necessarily complex if they are to include the effect of all the variables.

For some purposes, meaningful and useful estimates of sediment yield can be obtained from models, and the best example is the estimation of long-term average annual soil loss from a catchment by using the Universal Soil Loss Equation (USLE).

16.2 The Universal Soil Loss Equation (USLE)

The field soil loss estimation equations development began in 1940 in USA. Zing (1940) proposed a relationship of soil loss to slope length raised to a power. Later in 1947, a committee chaired by Musgrave proposed a soil-loss equation having some similarity to the present day USLE. Based on nearly 10,000 plot year runoff plot data, Wischmeier and Smith (1965) developed the universal soil loss equation, which was later refined with more recent data from runoff plots, rainfall simulators and field experiences. It is the most widely used tool for estimation of soil loss from agricultural watersheds for planning erosion control practices. The USLE is an erosion prediction model for estimating long term averages of soil erosion from sheet and rill erosions from a specified land under specified conditions (Wischmeier and Smith, 1978).

It provides an estimate of the long-term average annual soil loss from segments of arable land under various cropping conditions. The application of this estimate is to enable farmers and soil conservation advisers to select combinations of land use, cropping practice, and soil conservation practices, which will keep the soil loss down to an acceptable level. The equation (USLE) is presented as below.

$$A = R \times K \times L \times S \times C \times P \quad (16.1)$$

where, A = soil loss per unit area in unit time, $t \text{ ha}^{-1} \text{ yr}^{-1}$, R = rainfall erosivity factor which is the number of rainfall erosion index units for a particular location, K = soil erodibility factor - a number which reflects the susceptibility of a soil type to erosion, i.e., it is the reciprocal of soil resistance to erosion, L = slope length factor, a ratio which compares the soil loss with that from a field of specified length of 22.6 meters, S = slope steepness factor, a ratio which compares the soil loss with that from a field of specified slope of 9%, C = cover management factor - a ratio which compares the soil loss with that from a field under a standard treatment of cultivated bare fallow, and P = support practice factor - a ratio of soil loss with support practice like contouring, strip cropping or terracing to that with straight row farming up and down the slope.

The factors L , S , C and P are each dimensionless ratios which allow comparison of the site for which soil loss is being estimated with the standard conditions of the database. Knowing the values of rainfall erosivity, soil erodibility and slope one can calculate the effectiveness of various erosion control measures with the purpose of introducing a cultivation system in an area with soil loss limited to the acceptable value.

Various factors associated with the above equation are discussed below.

- **Rainfall Erosivity Factor (R)**

It refers to the rainfall erosion index, which expresses the ability of rainfall to erode the soil particles from an unprotected field. It is a numerical value. From the long field experiments it has been obtained that the extent of soil loss from a barren field is directly proportional to the product of two rainfall characteristics: kinetic energy of the storm and its 30-minute maximum intensity. The product of these two characteristics is termed as EI or EI_{30} or rainfall erosivity. The erosivity factor, R is the number of rainfall erosion index units (EI_{30}) in a given period at the study location. The rainfall erosion index unit (EI_{30}) of a storm is estimated as:

$$EI_{30} = \frac{KE \times I_{30}}{100} \quad EI_{30} = KE \times I_{30} \quad (16.2)$$

where, KE = kinetic energy of storm in metric tones /ha-cm, expressed as

$$KE = 210.3 + 89 \log I \quad KE = 210.3 + 89 \log I \quad (16.3)$$

where, I = rainfall intensity in cm/h, and I_{30} = maximum 30 minutes rainfall intensity of the storm.

The study period can be a week, month, season or year and this I_{30} values are different for different areas. The storm EI_{30} values for that length of period is summed up. Annual EI_{30} values are usually computed from the data available at various meteorological stations and lines connecting the equal EI_{30} values (known as *Iso-erodent lines*) are drawn for the region covered by the data stations for ready use in USLE.

- **Soil Erodibility Factor (K)**

The soil erodibility factor (K) in the USLE relates to the rate at which different soils erode. Under the conditions of equal slope, rainfall, vegetative cover and soil management practices, some soils may erode more easily than others due to inherent soil characteristics. The direct measurement of K on unit runoff plots reflect the combined effects of all variables that significantly influence the ease with which a soil is eroded or the particular slope other than 9% slope. Some of the soil properties which affect the soil loss to a large extent are the soil permeability, infiltration rate, soil texture, size and stability of soil structure, organic content and soil depth. These are usually determined at special experimental runoff plots or by the use of empirical erodibility equations which relate several soil properties to the factor K. The soil erodibility factor (K) is expressed as tons of soil loss per hectare per unit rainfall erosivity index, from a field of 9% slope and 22 m (in some cases 22.13 m) field length. The soil erodibility factor (K) is determined by considering the soil loss from continuous cultivated fallow land without the influence of crop cover or management.

The formula used for estimating K is as follows:

$$K = \frac{A_o}{S \times (\Sigma EI)} \quad K = \frac{A_o}{S \times (\Sigma EI)} \quad (16.4)$$

where, K = soil erodibility factor, A_o = observed soil loss, S = slope factor, and ΣEI = total rainfall erosivity index.

Based on runoff plot studies, the values of erodibility factor K have been determined for use in USLE for different soils of India as reported by Singh *et al.* (1981). Values of K for several stations are given in Table 16.1.

Table 16.1. Values of K for Several Stations (Source: K. Subramanya, 2008)

Station	Soil Type	Computed Values of K
Agra	Loamy sand, alluvial	0.07
Dehradun	Dhulkot silt, loam	0.15
Hyderabad	Red chalka sandy loam	0.08
Kharagpur	Soils from laterite rock	0.04
Kota	Kota clay loam	0.11
Ootakamund	Laterite	0.04
Rehmankhera	Loam, alluvial	0.17
Vasad	Sandy loam, alluvial	0.06

Topographic Factor (LS)

Slope length factor (L) is the ratio of soil loss from the field slope length under consideration to that from the 22.13 m length plots under identical conditions. The slope length has a direct relation with the soil loss, i.e., it is approximately equal to the square root of the slope length ($L^{0.5}$), for the soils on which runoff rate is not affected by the length of slope (Zing, 1940).

Steepness of land slope factor (S) is the ratio of soil loss from the field slope gradient to that from the 9% slope under otherwise identical conditions. The increase in steepness of slope results in the increase in soil erosion as the velocity of runoff increases with the increase in field slope allowing more soil to be detached and transported along with surface flow.

The two factors L and S are usually combined into one factor LS called *topographic factor*. This factor is defined as the ratio of soil loss from a field having specific steepness and length of slope (i.e., 9% slope and 22.13 m length) to the soil loss from a continuous fallow land. The value of LS can be calculated by using the formula given by Wischmeier and Smith (1962):

$$LS = \frac{\sqrt{L}}{100} (0.76 + 0.53S + 0.076S^2)$$

$$LS = \frac{\sqrt{L}}{100} (0.76 + 0.53 S + 0.076 S^2) \quad (16.5)$$

where, L = field slope length in feet and S = percent land slope.

Wischmeier and Smith (1978) again derived the following equation for LS factor in M.K.S. system, based on the observations from cropped land on slopes ranging from 3 to 18% and length from 10 to 100 m. The derived updated equation is:

$$LS = \left(\frac{\lambda}{22.13} \right)^m [65.41 \sin^2 \theta + 4.56 \sin \theta + 0.065] \quad (16.6)$$

where, λ = field slope length in meters, m = exponent varying from 0.2 to 0.5, and θ = angle of slope.

Crop Management Factor (C)

The crop management factor C may be defined as the expected ratio of soil loss from a cropped land under specific crop to the soil loss from a continuous fallow land, provided that the soil type, slope and rainfall conditions are identical. The soil erosion is affected in many ways according to the crops and cropping practices, such as the kind of crop, quality of cover, root growth, water use by plants etc. The variation in rainfall distribution within the year also affects the crop management factor, which affects the soil loss. Considering all these factors, the erosion control effectiveness of each crop and cropping practice is evaluated on the basis of five recommended crop stages introduced by Wischmeier (1960). The five stages are:

Period F (Rough Fallow): It includes the summer ploughing or seed bed preparation.

Period 1 (Seed Bed): It refers to the period from seeding to 1 one month thereafter.

Period 2 (Establishment): The duration ranges from 1 to 2 months after seeding.

Period 3 (Growing Period): It ranges from period 2 to the period of crop harvesting.

Period 4 (Residue or Stubble): The period ranges from the harvesting of crop to the summer ploughing or new seed bed preparation.

For determining the crop management factor the soil loss data for the above stages is collected from the runoff plot and C is computed as the ratio of soil loss from cropped plot to the corresponding soil loss from a continuous fallow land for each of the above five crop stages separately, for a particular crop, considering various combinations of crop sequence and their productivity levels. Finally, weighted C is computed. This factor reflects the combined effect of various crop management practices. Values of factor C for some selected stations of India are given in Table 16.2.

Table 16.2. Values of Crop Management Factors for Different Stations in India (Source: K Subramanya, 2008)

Station	Crop	Soil Loss, t ha ⁻¹ y ⁻¹	Value of C
Agra	Cultivated fallow	3.80	1.0
	Bajra	2.34	0.61
	Dichanhium annualtu	0.53	0.13
Dehradun	Cultivated fallow	33.42	1.0
	Cymbopogon grass	4.51	0.13
	Strawberry	8.89	0.27
Hyderabad	Cultivated fallow	5.00	1.0
	Bajra	2.00	0.40

Support Practice Factor (P)

This factor is the ratio of soil loss with a support practice to that with straight row farming up and down the slope. The conservation practice consists of mainly contouring, terracing

and strip cropping. The soil loss varies due to different practices followed. Factor P for different support practices for some locations of India is presented in Table 16.3.

Table 16.3. Different Values of Support Practice Factor (P) for Some Indian Locations (Source: K. Subramanya, 2008)

Station	Practice	Factor P
Dehradun	Contour cultivation of maize	0.74
	Up and down cultivation	1.00
	Contour farming	0.68
	Terracing and bunding in agricultural watershed	0.03
Kanpur	Up and down cultivation of Jowar	1.00
	Contour cultivation of Jowar	0.39
Ootacamund	Potato up and down	1.00
	Potato on contour	0.51

16.3 Use of USLE

There are three important applications of the universal soil loss equation. They are as follows:

- It predicts the soil loss;
- It helps in identification and selection of agricultural practices; and
- It provides the recommendations on crop management practices to be used.

USLE is an erosion prediction model and its successful application depends on the ability to predict its various factors with reasonable degree of accuracy. It is based on considerably large experimental data base relating to various factors of USLE.

Based on 21 observation points and 64 estimated erosion values of soil loss obtained by the use of USLE at locations spread over different regions of the country, soil erosion rates have been classified into 6 categories. Areas falling under different classes of erosion are shown in Table 16.4.

Table 16.4. Distribution of various erosion classes in India (Source: K Subramanya, 2008)

Range (Tones/ha/year)	Erosion Class	Area (km ²)
0-5	Slight	801,350
5-10	Moderate	1,405,640
10-20	High	805,030
20-40	Very high	160,050
40-80	Severe	83,300
>80	Very severe	31,895

16.4 Limitations of Universal Soil Loss Equation

The equation involves the procedure for assigning the values of different associated factors on the basis of practical concept. Therefore, there is possibility to introduce some errors in selection of the appropriate values, particularly those based on crop concept. Normally R and K factors are constants for most of the sites/regions in the catchment, whereas, C and LS vary substantially with the erosion controlled measures, used. The following are some of the limitations of the USLE:

- **Empirical**

The USLE is totally empirical equation. Mathematically, it does not illustrate the actual soil erosion process. The possibility to introduce predictive errors in the calculation is overcome by using empirical coefficients.

- **Prediction of Average Annual Soil Loss**

This equation was developed mainly on the basis of average annual soil loss data; hence its applicability is limited for estimation of only average annual soil loss of the given area. This equation computes less value than the measured, especially when the rainfall occurs at high intensity. The storage basin whose sediment area is designed on the basis of sediment yield using USLE should be inspected after occurrence of each heavy storm to ensure that the sedimentation volume in the storage basin is within the limit.

- **Non-computation of Gully Erosion**

This equation is employed for assessing the sheet and rill erosions only but can not be used for the prediction of gully erosion. The gully erosion caused by concentrated water flow is not accounted by the equation and yet it can cause greater amount of soil erosion.

- **Non-computation of Sediment Deposition**

The equation estimates only soil loss, but not the soil deposition. The deposition of sediment at the bottom of the channel is less than the total soil loss taking place from the entire watershed. Nevertheless, the USLE can be used for computing the sediment storage volume required for sediment retention structures., Also the USLE equation can be used as a conservative measure of potential sediment storage needs, particularly where sediment basins ranges typically from 2-40 ha and runoff has not traveled farther distance and basin is intended to serve as the settling area. Again, if the drainage on any site is improperly controlled and gully erosion is in extensive form, then this equation underestimates the sediment storage requirement of the retention structure.

During the estimation of contribution of hill slope erosion for basin sediment yield, care should be taken as it does not incorporate sediment delivery ratio. This equation cannot be applied for predicting the soil loss from an individual storm, because the equation was derived to estimate the long term mean annual soil loss. The use of this equation should be avoided for the locations, where the values of different factors associated with the equation, are not yet determined.

16.5 Revised Universal Soil Loss Equation (RUSLE)

Over the last few decades, a co-operative effort between scientists and users to update the USLE has resulted in the development of RUSLE. The modifications incorporated in USLE to result the RUSLE are mentioned as under (Kenneth *et.al.* 1991):

- Computerizing the algorithms to assists the calculations.
- New rainfall-runoff erosivity term (R) in the Western US, based on more than 1200 gauge locations.
- Some revisions and additions for the Eastern US, including corrections for high R-factor areas with flat slopes to adjust splash erosion associated with raindrops falling on ponded water.
- Development of a seasonally variable soil erodibility term (K).
- A new approach for calculating the cover management term (C) with the sub-factors representing considerations of prior land use, crop canopy, surface cover and surface roughness
- New slope length and steepness (LS) algorithms reflecting rill to inter-rill erosion ratio
- The capacity to calculate LS products for the slopes of varying shapes
- New conservation practices value (P) for range lands, strip crop rotations, contour factor values and subsurface drainage.

16.6 Modified Universal Soil Loss Equation (MUSLE)

The USLE was modified by Williams in 1975 to MUSLE by replacing the rainfall energy factor (R) with another factor called as 'runoff factor'. The MUSLE is expressed as

$$Y = 11.8(Q \times q_p)^{0.56} K(LS)CP \quad Y = 11.8(Q \times q_p)^{0.56} K(LS)CP \quad (16.12)$$

where, Y = sediment yield from an individual storm (in metric tonnes), Q = storm runoff volume in m^3 and q_p = the peak rate of runoff in m^3/s .

All other factors K , (LS) , C and P have the same meaning as in USLE (equation 16.1). The values of Q and q_p can be obtained by appropriate runoff models. In this model Q is considered to represent detachment process and q_p is the sediment transport. It is a sediment yield model and does not need separate estimation of sediment delivery ratio and is applicable to individual storms. Also it increases sediment yield prediction accuracy. From modeling point of view, it has the advantage that daily, monthly and annual sediment yields of a watershed can be modeled by combining appropriate hydrological models with MUSLE.



AGRIMOON.COM

All About Agriculture...

Lesson 17 Erosivity and Erodibility

Soil degradation is indicated by lowering of the fertility status, by a reduction of the nutrient level or by physical loss of topsoil. The latter condition, mostly occurs in regions prone to soil erosion where during heavy rainfall considerable amounts of soil, rock debris and organic matter are transported down slope to rivers and eventually to the sea. Soil erosion control can be attained by knowing soils' susceptibility and the factors responsible for the susceptibility. Generally, the quantity of erosion yield is dependent upon the ability of rain to detach the soil particles (i.e., erosivity of rainfall) and at the same time the susceptibility of soil to withstand against the raindrop (i.e., erodibility of soil). Thus, the soil erosion is the function of both erosivity and erodibility. When rainfall erosivity exceeds the soil erodibility, soil erosion occurs.

17.1 Erosivity of Rainfall

Rainfall erosivity is a term that is used to describe the potential for soil to be washed off from disturbed, de-vegetated areas and move with into surface waters during storms. It may also be defined as the potential ability of rain to cause the erosion. It is dependent upon the physical characteristics of rainfall, which include raindrop size, drop size distribution, kinetic energy, terminal velocity, etc. For a given soil condition, the potential of two storms can be compared quantitatively, regarding soil erosion to be caused by them. The power of overland runoff flow to erode soil material is partly a property of the rainfall, and partly of the soil surface. Rainfall erosivity is highly related to soil loss. Increased rain erosivity indicates greater erosive capacity of the overland water flow. Soil erosion by running water occurs where the intensity and duration of rainstorms exceeds the capacity of the soil to infiltrate the rainfall. The potential for erosion is based on many factors which include including soil type, slope, and the energy or force of precipitation expected during the period of surface disturbance.



Fig. 17.1. Tilled Farmland Very Susceptible to Erosion from Rainfall.

17.1.1 Factors Affecting Rainfall Erosivity

The various factors, which affect the erosivity of rain storm, are given as under:

1) Rainfall Intensity

Rainfall intensity refers to the rate of rainfall over the land surface. It is one of the most important factors responsible for the erosive nature of rainfall. The rainfall intensity is assumed as the force, by which an individual water droplets strikes over the soil surface. The kinetic energy is related to the intensity of rainfall by the equation proposed by Wischmeier and Smith (1958) as follows:

$$KE = 210.3 + 89 \log_{10} I \quad E_k = 210.3 + 89 \log_{10} I \quad (17.1)$$

where, KE = kinetic energy of rainfall, tons per ha per cm of rainfall, and I = rainfall intensity (cm/h).

2) Drop Size Distribution

The drop size distribution in a particular rainstorm influences the energy, momentum and erosivity of the rain in cumulative way. The increases in median drop size, increases the rainfall intensity. The relationship between the median drop size (D_{50}) and rainfall intensity, is given as under (Laws and Parsons, 1943):

$$D_{50} = 2.23 I^{0.182} \quad (17.2)$$

In which, D_{50} is the median drop size (inch) and I is the intensity (inch/h).

3) Terminal Velocity

The effect of terminal velocity of falling raindrops is counted in terms of kinetic energy of respective rain drops at the time of their impact over the soil surface. It is the function of drop size. A rainstorm composed of large proportion of bigger size raindrops, has greater terminal velocity and vice-versa. The kinetic energy of rain storm has following relationship with terminal velocity, as:

$$E_k = \frac{IV^2}{2} \quad (17.3)$$

where,

E_k = rainfall energy (watts /m²)³, I = Intensity of rainfall (mm/s), and V = Terminal velocity of rainfall before impact (m/s).

Ellison (1947) developed an empirical relationship among the terminal velocity, drop diameter and rainfall intensity, for computing the amount of soil detached by the rainfall as:

$$E = K.V^{4.33} d^{1.07} I^{0.65} \quad (17.4)$$

where, E = relative amount of soil detached, K = a constant, depends upon the soil characteristics, V = velocity of raindrop (feet/s), d = drop diameter (mm), and I = rainfall intensity (inch/h).

4) Wind Velocity

Wind velocity affects the power of rainfall to cause soil detachment, by influencing the kinetic energy of rain storm. Tropical regions experience the occurrence of windy storm most of the times. Wind driven storms are more effective than anticipated for breaking the aggregates. The effect of wind velocity on soil detachment by rain storm is shown in Table 1.

Table 17.1. Effect of Wind Velocity on Soil Detachment at Different Intensities of Rain Storm. (Source: Lyles et.al, 1969)

Wind Velocity (m/s)	Intensity of Rain (cm/h)		
	1.6	2.84	5.61
	% Soil Detachment (arbitrary unit)		
0	56	93	97
6.7	95	98	97
13.4	97	100	100

5) Direction of Slope

The direction of land slope also develops significant effect on rainfall erosivity. Slope direction in the direction of the rain storm, effectively alters the actual kinetic energy of the rain drop. It increases the impact force of the raindrop as the velocity component in the direction of slope becomes more.

17.1.2 Estimation of Erosivity from Rainfall Data

The rainfall erosivity is related to the kinetic energy of rainfall. The following two methods are widely used for computing the erosivity of rainfall.

1. EI_{30} Index method and
2. $KE > 25$ Index method.

1. EI_{30} Index Method

This method was introduced by Wischmeier (1965). It is based on the fact that the product of kinetic energy of the storm and the 30-minute maximum rainfall intensity gives the best estimation of soil loss. The greatest average intensity experienced in any 30 minute period during the storm is computed from recording rain gauge charts by locating the maximum amount of rain which falls in 30 minute period and later converting the same to intensity in

mm/hour. This measure of erosivity is referred to as the EI_{30} index and can be computed for individual storms, and the storm values can be added over periods of time to give weekly, monthly or yearly values of erosivity.

The rainfall erosivity factor EI_{30} value is computed as follows:

$$EI_{30} = KE \times I_{30} \quad EI_{30} = KE \times I_{30} \quad (17.5)$$

where KE is rainfall kinetic energy and I_{30} is the maximum rainfall intensity for a 30-minute period. Kinetic energy for the storm is computed from Eqn. 17.1.

Limitation

The EI_{30} index method was developed under American condition and is not found suitable for tropical and sub-tropical zones for estimating the erosivity.

2. KE > 25 Index Method

This is an alternate method introduced by Hudson for computing the rainfall erosivity of tropical storms. This method is based on the concept that erosion takes place only at threshold value of rainfall intensity. From experiments, it was obtained that the rainfall intensities less than 25 mm/h are not able to yield the soil erosion in significant amount. Thus, this method takes care of only those rainfall intensities, which are greater than 25 mm/h. That is why the name is K.E. > 25 Index method. It is used in the same manner as the EI_{30} index and the calculation procedure is also similar.

Calculation Procedure

The estimation procedure is same for both the methods. However, K.E. > 25 method is more advantageous, because it sorts out many data less than 25 mm/h, hence uses less rainfall data. For both the methods, it is important to have data on rainfall amount and its intensity.

The procedure involves the multiplication of rainfall amounts in each class of intensity to the computed kinetic energy values and then all these values are added together to get the total kinetic energy of the storm. The K.E. so obtained, is again multiplied by the maximum 30-minute rainfall intensity to determine the rainfall erosivity value.

17.2 Soil Erodibility

Soil erodibility is an estimate of the ability of soils to resist erosion based on the physical characteristics of each soil. Generally, soils with faster infiltration rates, higher levels of organic matter and improved soil structure have a greater resistance to erosion. Sand, sandy loam and loam textured soils tend to be less erodible than silt, very fine sand, and certain clay textured soils (Fig. 17.2). On the basis of erodibility, a soil can be compared quantitatively with the other soils for a given rainfall condition. Bouyoucos (1935) suggested that the soil erodibility depends on mechanical composition of soil, such as sand, silt, and clay, presented by the ratio as:

$$\text{Erodibility, } E = \frac{\% \text{ sand} + \% \text{ silt}}{\% \text{ clay}} \quad (17.6)$$

The range of particle diameter of clay, sand and silt is:

Clay = < 0.002 mm

Silt = 0.002 – 0.006 mm

Sand = 0.06 - 2.0 mm.

This indicator is reliable only in some cases.

Tillage and cropping practices which lower soil organic matter levels, cause poor soil structure, and result in soil compactness contribute to increases in soil erodibility. Decreased infiltration and increased runoff can be a result of compacted subsurface soil layers. A decrease in infiltration can also be caused by a formation of a soil crust, which tends to "seal" the surface. On some sites, a soil crust might decrease the amount of soil loss from sheet or rain splash erosion, however, a corresponding increase in the amount of runoff water can contribute to greater rill erosion problems.

Past erosion has an effect on soil erodibility for a number of reasons. Many exposed subsurface soils on eroded sites tend to be more erodible than the original soils were, because of their poorer structure and lower organic matter. The lower nutrient levels often associated with subsoils contribute to lower crop yields and generally poorer crop cover, which in turn provides less crop protection for the soil.

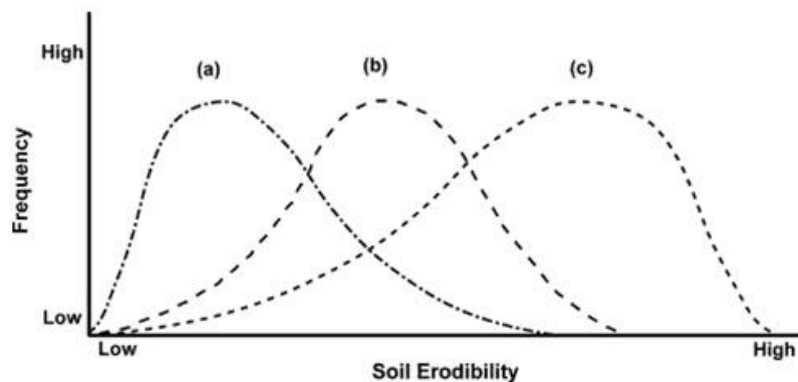

Fig. 17.2. Conceptual Diagram Showing the Frequency Distributions of Three Soils in the Erodibility Continuum. These could Represent the Same Soil Type under Three Levels of Disturbance Intensity, for example Under Low (a), Moderate (b) or High (c) Stocking Rates or the Responses of Three Different Soils, for example A Clay (a), A Loam (b) and A Sand (c) to A Similar Level of Disturbance

17.2.1 Erodibility Determination

Erodibility is defined as the resistance of the soil to both detachment and transport. It varies with soil texture, aggregate stability, shear strength, infiltration capacity and organic and chemical content. Erodibility of a soil is designated by the soil erodibility factor K . There are several approaches to determine K and the three major ones are discussed as given below.

1. Use of *in situ* erosion plots
2. Measuring K under a simulated rainstorm
3. Predicting K using regression equations describing the relationship between K and soil physical and chemical properties.

- **In Situ Erosion Plots**

Erosion plots enable measurement of K under field conditions. They make use of a standard condition of bare soil with no conservation practice and 7° slope of 22.13 m length of plots. This approach is costly and time consuming.

Measuring K under a Simulated Rainstorm

This approach is less time consuming but relatively costly. The main drawback is that none of the rainfall simulators built to date can recreate all the properties of natural rain. Nevertheless this method is being used more extensively in erosion studies.

The rainfall simulator, generally used in this study, is made of Duction bars. It measures 1.80 m both in length and width and is 3.80 m high. Several kinds of nozzle are tested and the one that produces water droplets close to natural rain is chosen. Water is released at a low pressure. A wooden tray of dimension 1 m by 2 m and 15 cm deep is placed under the simulator with the slope adjusted to 7°. A collecting structure is placed at the downslope end to gather runoff and sediment. Soil samples collected from different erosion-sensitive regions are placed in the wooden tray. The soil is then subjected to simulated rainstorm of different intensities. Since, it is difficult to set predetermined rainfall intensity, the nozzle is adjusted to low and high levels and the depth of water reaching the wooden tray is measured using a beaker throughout the experiment. Total volume of runoff and sediment are collected and measured.

Predicting K

K may be predicted using regression equations describing the relationships between K and soil chemical and physical properties. The nomograph developed by Wischmeier et al. (1971) expressing the relationship between K and soil properties is based on the following equation:

$$100K = 2.1 \times 10^4 \times (2 - OM) \times m^{1.14} + 3.25 \times (St - 2) + 2.5 \times (Pt - 3)$$

$$100K = 2.1 \times 10^4 \times (2 - OM) \times m^{1.14} + 3.25 \times (St - 2) + 2.5 \times (Pt - 3) \quad \dots (17.6)$$

where, OM = Organic matter content (%), m = Silt plus fine sand content (%), St = Soil structure code (very fine granular = 1; fine granular = 2; coarse granular = 3; blocky, platy or massive = 4), Pt = Permeability class (rapid = 1, moderate to rapid = 2, moderate = 3, slow to moderate = 4, slow = 5, very slow = 6), and K is predicted using the nomograph devised by Wischmeier et al. (1971).

17.3 Relationship between Rainfall Energy and Soil Erosion

It is well-established that the amount of soil that is detached by a particular depth of rainfall is related to the intensity at which this rain falls. The results of various studies further suggest that soil splash rate is a combined function of rainfall intensity and some measure of raindrop fall velocity (Ellison, 1944).

The relationship is given by:

$$S \propto V^{4.3} \cdot D^{1.07} \cdot I^{0.65} \quad S \propto V^{4.3} \cdot D^{1.07} \cdot I^{0.65} \quad (17.8)$$

where, S = quantity of soil splashed in 30 minutes duration, V = velocity of raindrop, ft./s, D = diameter of raindrop, mm and I = intensity of rainfall, inch/h.

Raindrop diameter in storms of varying intensity can be observed for each region, resulting in regressions such as: energy of a storm = energy of each segment of rain falling at a given intensity multiplied by the number of millimeters fallen at this intensity (Bisal, 1960).

The expression is given by:

$$G = K.D.V^{1.4} \qquad G = K.D.V^{1.4} \qquad (17.10)$$

where, G = weight of soil splashed in gm, K = constant, depends upon the soil type, D = drop diameter in mm, and V = impact velocity in m/s.

This impact energy is dissipated in four ways:

1. Compression of the soil under the rain's impact, following rapid moistening of the soil surface;
2. Crushing and shearing stress: separation of aggregated particles;
3. Projection of elementary particles in a crown formation on flat soil and transport in all directions but most effectively downhill on slopes.
4. Noise of the impact of the drops on resistant material.

Hudson (1965 and 1973) working in Zimbabwe, and Elwell and Stocking (1975) working on well-structured ferralitic soils (oxisols), found the best relation between erosion and raindrop energy above a certain threshold intensity ($I > 25$ mm/h) ($E = K E$, if $I > 25$ mm/h).

The above authors observed that only intense rain leads to erosion. However, it is likely that any rain will have some ill effect on the soil surface, even if not all rains produce runoff. , But they may foster the development of a fairly impermeable crust and accelerate runoff in future storms.

On the basis of mass and velocity of raindrop, Mihara (1959) also reported that the splash erosion is directly correlated with the kinetic energy of the raindrop. He developed the following relationship for two different types of soil, given as:

For sandy soil,

Splash erosion \propto K.E.^{0.9} and

For clay soil,

Splash erosion \propto K.E.^{1.46}

Solved Example

1. Find out the total kinetic energy of rainfall and also its erosivity using EI_{30} and K.E. > 25 index methods for the following given rainfall amount and intensity values.

Solution:**1. EI_{30} Index Method:**

Intensity (cm/h)	Amount (cm)	Energy (metric tones/ha/cm)	Total (col.2 × col.3)
(1)	(2)	(3)	(4)
1.5	3	231.97	695.91
2.5	0.75	245.71	184.28
3.5	1.25	258.72	323.40
4.5	2.58	268.43	692.56
5.5	3.57	276.19	986.00
			2882.15(metric tones/ha.)

Kinetic energy is calculated by the Eqn. 17.1;

Let I_{30} is taken to be 45 cm/h, the rainfall erosivity is given as

$$EI_{30} = 2882.15 \times 45 = 129696.75 \text{ metric tonnes/ha.cm/hr. Ans.}$$

2. K.E. > 25 Method:

Intensity (cm/h)	Amount (cm)	Energy (tons/ha cm)	Total (col.2 × col. 3)
(1)	(2)	(3)	(4)
0.015	0.5	47.97	23.98
1.5	2.52	225.97	569.44
1.67	0.021	230.12	4.83
0.025	0.75	67.71	50.78
			569.44 m tons/ha

For calculation of total kinetic energy, corresponding terms for rainfall intensity of less than 25 mm/h have not been considered. According to this method,

$$EI_{30} = 569.44 \times 45 = 25624.28 \text{ t/ha cm/h } \mathbf{Ans.}$$



AGRIMOON.COM

All About Agriculture...

Lesson 18 Estimation of USLE Parameters

The Universal Soil Loss Equation (USLE) predicts the long term average annual rate of erosion on a field slope based on rainfall pattern, soil type, topography, crop system and management practices. This erosion model was developed for use in selected cropping and management systems, but is also applicable to non-agricultural conditions such as construction sites. The USLE can be used to compare soil losses from a particular field with a specific crop and management system to "tolerable soil loss" rates. Alternative management and crop systems may also be evaluated to determine the adequacy of conservation measures in farm planning.

18.1 USLE Parameters

However, USLE predicts only the amount of soil loss that results from sheet or rill erosion on a single slope and does not account for additional soil losses that might occur from gully, wind or tillage erosion.

Five major factors are used to calculate the soil loss for a given site. Each factor is the numerical estimate of a specific condition that affects the severity of soil erosion at a particular location. The erosion values reflected by these factors can vary considerably due to varying weather conditions. Therefore, the values obtained from the USLE more accurately represent long-term averages.

USLE has been found to produce realistic estimates of surface erosion over areas of small sizes (Wischmeier & Smith, 1978). Therefore, soil erosion within a grid cell was estimated using the USLE. The USLE is expressed as:

$$A = R \times K \times L \times S \times C \times P \quad (18.1)$$

A = gross amount of soil erosion ($\text{t ha}^{-1} \text{yr}^{-1}$); it represents the potential long term average annual soil loss in tons per hectare per year. This is the amount, which is compared to the "tolerable soil loss" limits, R = rainfall factor related to rainfall-runoff erosion given in $\text{MJ.mm.ha}^{-1}\text{h}^{-1}$, K = soil erodibility factor related to soil erosion ($\text{t.ha.h.MJ}^{-1} \text{mm}^{-1}$), L = slope length factor (dimensionless), S = slope steepness factor (dimensionless), C = factor related to cover management (dimensionless); and P = conservation practice factor (dimensionless).

18.1.1 Description of Different Parameters of USLE

Rainfall Factor (R)

The erosivity factor to account for the erosive power of rainfall is related to the amount and intensity of rainfall over the year (erosivity index unit). Rainfall erosivity is a term used to describe the potential for soil to be washed off from disturbed, devegetated areas into surface waters during storms. The potential for erosion is based on many factors which include soil type, slope, and the energy or force of precipitation expected during the period of surface disturbance.

Soil Erodibility Factor (K)

The soil erodibility factor to account for the soil loss rate is an erosion index unit which is defined as the soil loss from a plot 22.1 m long on a 9% slope under a continuous bare cultivated fallow. It ranges from less than 0.1 for the least erodible soils to close to 1.0 in the worst possible case.

Topographic Factor (LS)

LS is the slope length-gradient factor. The topographic factor is used to account for the length and steepness of the slope. The longer the slope, the greater is the volume of surface runoff and the steeper the slope, the greater is its velocity. LS is 1.0 on a 9% slope and for a 22.1 meter long plot.

Crop Management Factor (C)

C is the crop/vegetation and management factor. It is used to determine the relative effectiveness of soil and crop management systems in terms of preventing soil loss. The C factor is a ratio of the soil loss from a land under a specific crop and management system to the corresponding loss from a continuously fallow and tilled land. The C Factor can be determined by selecting the crop type and tillage method.

The cover and management factor to account for the effects of vegetative cover and management techniques for reduction of the soil loss would be equal to 1.0 in the worst case. In an ideal case when there is no sediment loss, C would be zero.

Support Practice Factor (P)

P is the support practice factor. It reflects the effects of practices that will reduce the amount and rate of the runoff and thus reduce the amount of erosion. The P factor represents the ratio of soil loss by a support practice to that of straight-row farming up and down the slope. The most commonly used supporting cropland practices are cross slope cultivation, contour farming and strip-cropping. Ideally in an area with full support practice condition, P would be zero meaning there is no sediment loss; whereas in an area without any support practice P = 1.0 indicating maximum possible sediment loss in absence of any soil conservation practice.

18.2 Assumptions and Estimation of USLE Parameters

Wischmeier (1976) reported that the USLE may be used to predict the average-annual soil loss from a field-sized plot with specified land use conditions (Mitchell and Bubenzer 1980). The assumptions associated with the USLE are as follows (Goldman et. al. 1986; Novotny and Chesters 1981; Foster 1976; Onstad and Foster 1975):

- The USLE is an empirically derived algorithm and does not mathematically represent the actual erosion process.
- The USLE was developed to estimate long-term, average-annual, or seasonal soil loss. Unusual rainfall seasons, especially higher than normal rainfall and typically heavy storms may produce more sediment than estimated.
- The USLE estimates soil loss on upland areas only; it does not estimate sediment deposition. Sediment deposition generally occurs at the bottom of a slope (i.e., change in grade) where the slope becomes milder.

- The USLE estimates sheet, rill, and inter-rill erosion and does not estimate channel or gully erosion. Gully erosion, caused by concentrated flows of water, is not accounted for by the equation and yet can produce large volumes of eroded soil.
- The USLE was developed originally to address soil loss from field-sized plots, although with proper care, watersheds can be addressed.
- Because the USLE only estimates the volume of sediment loss (i.e., the volume of soil detached and transported some distance), it can be used to estimate sediment transport capacity at a site.
- Because the USLE represents an empirically derived expression, consistently accurate estimates of soil loss are fortuitous at best.
- The USLE does not estimate soil loss from single storm events unless a modified form of the original equation is used.

18.2.1 Estimation of USLE Parameters

1. Rainfall Erosivity (R)

The following two methods are widely used for computing the erosivity of rainfall.

a) EI_{30} index method.

b) $KE > 25$ index method.

a) EI_{30} Index Method

This method was introduced by Wischmeier (1965). It is based on the fact that the product of kinetic energy of the storm and the 30-minute maximum rainfall intensity gives the best estimation of soil loss. The greatest average intensity experienced in any 30 minute period during the storm is computed from recording raingauge charts by locating the maximum amount of rain which falls in 30 minute period and later converting the same to intensity in mm/hour. This measure of erosivity is referred to as the EI_{30} index and can be computed for individual storms, and the storm values can be added over periods of time to give weekly, monthly or yearly values of erosivity.

The rainfall erosivity factor EI_{30} which gives R value is computed as follows:

$$EI_{30} = KE \times I_{30} \quad (18.2)$$

where KE is the rainfall kinetic energy and I_{30} is the rainfall intensity for a 30-minute period. Kinetic energy for the storm is computed using Eqn.17.1.

Limitation

The EI_{30} index method was developed under American conditions and is not found suitable for tropical and subtropical zones for estimating the erosivity.

b) KE > 25 Index Method

This is an alternate method introduced by Hudson for computing the rainfall erosivity of tropical storms. This method is based on the concept that, erosion takes place only at threshold value of rainfall intensity. From experiment, it was obtained that rainfall intensity less than 25 mm/h are not able to cause soil erosion in significant amount. Thus, this method takes care of only those rainfall intensities, which are greater than 25 mm/h. Due to this reason, it is named as K.E.> 25 index method.

Calculation Procedure

The estimation procedure is same for both the methods. However, K.E.> 25 method is more advantageous, because it sorts out all the data with rainfall intensity of less than 25 mm/h and therefore, requires less rainfall data. For application of both the methods it is essential to have data on rainfall amount and intensity.

The procedure involves multiplication of rainfall amounts in each class of intensity to the computed kinetic energy values and then all these values are added together to get the total kinetic energy of storm. The K.E. so obtained is again multiplied by the maximum 30-minute rainfall intensity, to determine the rainfall erosivity value.

2. Soil Erodibility (K)

Erodibility of a soil is designated by the soil erodibility factor K . The formula used for estimating K is as follows:

$$K = \frac{A_o}{S \times (\sum EI)} K = \frac{A_o}{S \times (\sum EI)} \quad (18.3)$$

where, K = soil erodibility factor, A_o = observed soil loss, S = slope factor and $\sum EI$ = total rainfall erosivity index.

Although several techniques are available to determine the value of K , three important approaches are discussed below.

1. Use of In Situ Erosion Plots
2. Measuring K under a Simulated Rainstorm
3. Predicting K using Regression Equations Describing the Relationship between K and Soil Physical and Chemical Properties.

1. In Situ Erosion Plots

Erosion plots enable measurement of K under field conditions. They make use of a standard condition of bare soil, no conservation practice and 7° slope of 22m with 22 m length of plot. This approach is costly and time consuming.

2. Measuring K under a Simulated Rainstorm

This approach is less time consuming but relatively costly. The main drawback is that none of the rainfall simulators built to date can recreate all the properties of natural rain. Nevertheless this method is being used more extensively in erosion studies.

The rainfall simulator used in this study is made of Duction bars and measures 1.80 m by 1.80 m and 3.80 m high. Several kinds of nozzles are tested and the one that produces water droplets close to natural rain is chosen. Water is released at a low pressure. A wooden tray of dimension 1 m by 2 m and 15 cm deep is placed under the simulator with the slope adjusted to 7°. The tray is properly packed with the test soil. A collecting structure is placed at the down slope end to gather runoff and sediment. Soil samples are collected from different erosion-sensitive regions placed in the wooden tray.

The soil is then subjected to simulated rainstorm of different intensities. Since, it is difficult to set a predetermined rainfall intensity, the nozzle is adjusted to low and high levels and the depth of water reaching the wooden tray is measured throughout the experiment using a beaker. For all the experiments, runoff and sediments are collected and measured.

3. Predicting K using Regression Equations

K may be predicted using regression equations describing the relationships between K and soil chemical and physical properties. The nomograph developed by Wischmeier et al. (1971) expressing the relationship between K and soil properties is based on the following equation:

$$100K = 2.1 \times 10^4 \times (2 - OM) \times m^{1.14} + 3.25 \times (St - 2) + 2.5 \times (Pt - 3) \quad (18.4)$$

where OM = organic matter content (%), m = silt plus fine sand content (%), St = soil structure code (very fine granular = 1, fine granular = 2, coarse granular = 3, blocky, platy or massive = 4), Pt = permeability class (rapid = 1, moderate to rapid = 2, moderate = 3, slow to moderate = 4, slow = 5, very slow = 6). Based on the above equation, Wischmeier et al. (1971) developed a nomograph which is used to predict K .

3. Topographic Factor (LS)

Slope length factor (L) is the ratio of soil loss from a 22.13 m length plot under identical conditions. The soil loss has a direct relationship with the slope length i.e., it is approximately proportional to the square root of the slope length ($L^{0.5}$).

Steepness of land slope factor (S) is the ratio of soil loss from the existing field slope gradient to that from the 9% slope under otherwise identical conditions. The increase in steepness of slope results in the increase in soil erosion as because the velocity of runoff increases with the increase in field slope allowing more soil to be detached and transported along with surface flow.

The two factors L and S are usually combined into one factor LS called topographic factor. This factor is defined as the ratio of soil loss from a field having specific steepness and length of slope (i.e., 9% slope and length 22 m) to the soil loss from a continuous fallow land. The value of LS can be calculated by using the formula given by Wischmeier and Smith (1962):

$$LS = \frac{\sqrt{L}}{100} (0.76 + 0.53 S + 0.076 S^2)$$

$$LS = \frac{\sqrt{L}}{100} (0.76 + 0.53 S + 0.076 S^2) \quad (18.5)$$

where, L = Field slope length in feet and S = percent land slope.

Wischmeier and Smith (1978) based on the observations from crop land on slopes ranging from 3 to 18% and length from 10 to 100 m, derived the following equation for LS factor in M.K.S. system .

$$LS = \left(\frac{\lambda}{22.13} \right)^m [65.41 \sin^2 \theta + 4.56 \sin \theta + 0.065]$$

$$LS = \left(\frac{\lambda}{22.13} \right)^m (65.41 \sin^2 \theta + 4.56 \sin \theta + 0.065) \quad (18.6)$$

where, λ = field slope length in meters, m = exponent factor varying from 0.2 to 0.5 and θ = angle of slope.

Mc Cool et al. (1987) further modified the slope steepness factor for use in USLE, described as under.

- **For Shorter Slopes not greater than 4 m**

For this specific condition, the S can be predicted by the following equation:

$$S = [3.0(\sin \theta)^{0.8} + 0.56] S = [3.0 ((\sin \theta))^{0.8} + 0.56] \quad (18.7)$$

where, θ = the angle of slope and S = percent land slope.

- **For Longer Slopes**

From an analysis, two relationships were derived. One is applicable to slopes less than 9% and the other one for slopes equal to or greater than 9%. The revised equations are as follows:

- **Slope less than 9%**

$$S = 10.8 \sin \theta + 0.03 \quad (18.8)$$

- **Slope equal to or greater than 9%**

$$S = 16.8 \sin \theta - 0.50 \quad (18.9)$$

These equations apply best to relatively smooth surfaces, where tillage is up and down the hill and runoff does not vary with the slope for steepness above 8%.

- For the condition, where erosion is mainly caused by surface flow overthrowing the soil, the following equations for S have also been developed.

- (a) **Slope less than 9%**

$$S = 10.8 \sin \theta + 0.03 \quad (18.10)$$

- (b) **Slope equal to greater than 9%**

$$S = \left(\frac{\sin \theta}{0.0896} \right)^{0.6} \quad (18.11)$$

4. Crop Management Factor, C

This is an important factor of USLE, because it accounts for the condition that can be easily managed on soil to reduce the erosion. The value of C is determined as a weighted average of soil loss ratios (SLRs), defined as the ratio of soil loss for a given condition of vegetative cover at a specific time to that of the unit plot soil loss. As per this the definition, the SLRs vary within a year duration, as the soil cover conditions are likely to change appreciably during a year. To obtain the C value, the SLRs are weighted according to the erosivity distribution during the entire year.

To compute SLRs, a sub-factor method is introduced, which is a function of four sub-factors as given below:

1. Prior land use sub-factor (PLU)
2. Crop canopy sub-factor (CC)
3. Surface cover sub-factor (SC)
4. Surface roughness sub-factor (SR)

The sub-factor relationship is given as under:

$$C = PLU \times CC \times SC \times SR \quad C = PLU \cdot CC \cdot SC \cdot SR \quad (18.12)$$

The values of sub-factors PLU and SR for soil effect, are determined with the help of existing bio-mass amount in the soil that is accumulated from the crop's root and incorporation of crop residues. For computation of sub-factor value for SLRs, the characteristics of tillage operation play an important role.

The surface roughness factor SC is determined based on the effect of surface ground cover on erosion as given by equation (18.13).

$$SC = \exp^{-bM} \quad SC = \exp(-bM) \quad (18.13)$$

where, b = coefficient, assigned as 0.035. Its value increases as the tendency of rill erosion to dominate inter rill erosion increases and M = percentage of ground cover.

5. Conservation Practices Factor, P

To determine the conservation practice factor, entire area can be divided into three categories,

1. Straight rows
2. Straight rows with grassed waterways
3. Terraces

Then the following equation is used to estimate P:

$$P = (1 \times SR) + (0.30 \times SRWW) + (P_t \cdot T) \quad (18.14)$$

Where, SR is the portion of area under straight rows. SRWW is the portion of area under straight rows and grassed waterways; P_t is the erosion control practice for terracing and T is referred as the terraced area.



AGRIMOON.COM

All About Agriculture...

Module 5: Sedimentation

Lesson 19 Sedimentation of Water Resources

Sediments play an important role in elemental cycling in the aquatic environment. They are responsible for transporting a significant proportion of many nutrients and contaminants. They also mediate their uptake, storage, release and transfer between environmental compartments. Most sediment in surface waters derives from surface erosion and comprises a mineral component, arising from the erosion of bedrock, and an organic component arising during soil-forming processes (including biological and microbiological production and decomposition). An additional organic component may be added by biological activity within the water body.

19.1 Sedimentation

Sediment is fragmented material, which is transported or deposited by water, air or ice as natural agents. Eventually sediment settles out and accumulates after transport; this process is known as *deposition*. Among all, water is the most widespread agent of sediments transport. Therefore, sediment yield from soil surface and its transportation by water is commonly considered for study purposes. When land disturbance activities occur, soil particles are transported by surface water movement. Soil particles transported by water are often deposited in streams, lakes, and wetlands. This soil material is called *sediment*. Sediment is the largest single nonpoint source pollutant and the primary factor in the deterioration of surface water quality. Land disturbing activities such as road construction and maintenance, timber harvesting, mining, agriculture, residential and commercial development, all contribute to this problem. There are three basic types of sediments: rock fragments, or clastic sediments; mineral deposits, or chemical sediments; and rock fragments and organic matter, or organic sediments. Dissolved minerals form by weathering of rocks exposed at the earth's surface. Organic matter is derived from the decaying remains of plants and animals.

Sedimentation: It is the processes of letting suspended material settle by gravity. Suspended material may be particles, such as clay or silts, originally present in the source water. More commonly, suspended material is created from material in the water and the chemical used in coagulation or in other treatment processes, such as lime softening. Sedimentation is accomplished by decreasing the velocity of the water being treated to a point below which the particles will no longer remain in suspension. When the velocity no longer supports the transport of the particles, gravitational force will remove them from the flow. Sedimentation is a general term for the processes of erosion, transport and deposition.

Sedimentology: It is the study of sediments and sedimentation.

19.2 Sources of Sedimentation

Sediment is delivered from two broad erosion sources. The first being sheet erosion and second being channel type erosion. Sheet erosion is primarily an upland source of sediment while channel type erosion; resulting from the concentrated flow of water; is comprised mainly of gully erosion, valley trenching, streambed and stream bank erosion.

The sources of sediment can be listed as below:

1. Erosion from agricultural, forest and waste lands,
2. Movement of soil mass due to landslides, slumps and soil creeps,
3. From gully by concentrated runoff,
4. Stream bank erosion including cutting of banks and scouring from bed,
5. Erosion caused by occurrence of flood in the watershed,
6. Incident to the roads, railroads, cleaning of houses, industries etc. and
7. Mining and dumps left as waste materials over the ground surface.

In sediment analysis, the estimation of total sediment load carried away through any stream has primary importance because based on the total sediment load, several preventive measures can be adopted. The relative contribution of different sediment sources varies from catchment to catchment. Therefore, consideration must be given to those sources whose contribution is more effective and steps should be taken for controlling them.

19.3 Factors Affecting Sedimentation of Water Resources

Several factors affect the separation of settleable solids from water. Some of the common types of factors are:

1. Land Use and Soil Type: Sediment yield is closely related to the soil type and land use. Vegetation provides cover on the soil surface in the form of blanket to protect it from the impact force of the rainfall. The energy of rain drop is dissipated resulting in reduction of splashing effect over the ground surface. At the same time vegetation also creates a hindrance in the flow of runoff; resulting in the reduction of flow velocity and ultimately causing minimal scouring of soil particles from the soil surface. Furthermore, the infiltration rate gets enhanced, which reduces the runoff and thereby sediment yield, too.

Soil type is an important variable to affect the sediment yield. For example if there are two types of soil, one is sandy and the other is clay soil; the sandy soil has greater problem of particles detachment due to its coarser characteristics, while the clay soil can not be detached easily due to finer nature. In sandy soil, the soil loss (sediment yield) is more compared to the later one. However, once detached, the clay particles can be transported more easily.

2. Catchment Size: There is an association between the rate of sediment production and size of catchment area, because of the fact that the total runoff yield is dependent upon the aerial extent of watershed. The peak flow per unit area decreases as the area increases while the period of surface runoff increases with area. The reason behind this is that; a catchment of larger area has greater time of concentration. As a result, more time is available to the water for infiltrating into the soil. Ultimately there would be higher runoff and soil loss or sediment yield. In a small size catchment there is a reverse trend. The relationship between sediment yield per unit area and catchment area is shown in Fig. 19.1.

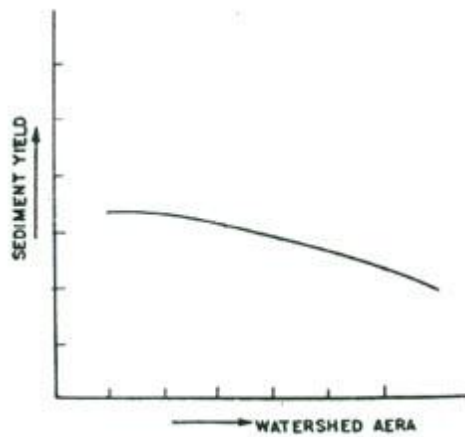

Fig. 19.1. Relationship between Sediment Yield and Area of Watershed. (Source: Suresh, 2009)

3. Climate and Rainfall: The relationship between sediment production and mean annual rainfall of the area has been investigated by several scientists. The general relationship between them is shown in Fig. 19.2 from which it can be seen that under dry conditions there is no surface runoff and no sediment movement, while under high rainfall conditions, there is a peak flow of surface runoff resulting in greater sediment yield.

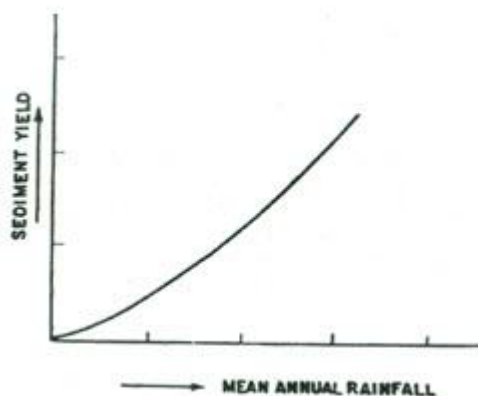

Fig. 19.2 Relationship between sediment yield and mean annual Rainfall. (Source: Suresh, 2009)

4. Particle Shape: The shape of the particle affects its settling characteristics. A round particle, for example, will settle much more readily than a particle that has rugged or irregular edges. All particles tend to have a slight electrical charge. Particles with the same charge tend to repel each other. This repelling action keeps the particles from congregating into flocs and settling.

5. Water Temperature: Another factor responsible for sedimentation process is the temperature of the water. When the temperature decreases, the rate of settling becomes slower. With the highest temperature, the settling process becomes much faster as density of water decreases at higher temperature.

19.4 Losses due to Sedimentation of Water Resources

Worldwide reservoir sedimentation is a serious problem and considered as a silent enemy. The gradual reduction of capacity reduces the effective life of dams and diminishes benefits

for irrigation, hydropower generation, flood control, water supply, navigation and recreation. On the other hand sediment deposition propagates upstream and up tributaries, raises local groundwater table, reduces channel flood carrying capacity and bridge navigation clearance and affects water division and withdrawals. On the other hand, the reduction of sediment load downstream can result in channel and tributary degradation, bank erosion and changes of the aquatic habits suited to a clear water discharge.

1. **Loss of Reservoir Storage Capacity:** The key impact of reservoir sedimentation is the reduction in the useful life of the reservoir. Sediment deposition is a key factor reducing the life of dams around the world. Reservoirs are expensive to build and their construction usually entails high social and environmental costs. Entire communities may be forced to relocate and ecosystems are destroyed due to their construction. However, it is recognized that dams also bring many benefits such as water storage, power generation and flood mitigation. Extending the life of dams through careful management of sediment, therefore, should be a key priority.
2. **Effects of Sediment on Hydropower Operations and Reservoir Operations:** The build-up of sediment in front of power intakes may result in significant costs for hydropower operations. Dredging is often required to remove excess sediment and allow a full flow of water through the intakes. If the sediment accumulation is high, the reservoir outlet works (intake and bottom outlet structures) may also become clogged. Abrasion of hydraulic machinery may also occur, decreasing its efficiency and increasing maintenance costs.
3. **Impacts on Infrastructure:** Too little sediment, especially downstream of dams, may encourage accelerated erosion around structures on/in riverbeds or riverbanks due to a lack of sediment recharge. In extreme cases, excessive erosion has led to incidents such as bridge collapses. Cracks in infrastructure such as bridges and other structures are typical results of such erosion. Aside from dams, sediment can have impacts on other man-made infrastructure. Too much sediment can disrupt the normal functioning of irrigation pump house intakes and can also disrupt irrigation when excess sediment is deposited in canal systems. Deposition in canal systems can lead to high costs for those reliant on these systems as a water supply. Dredging may be required to remove surplus sediment. Sediment deposition may also result in blockages or inefficiencies in irrigation infrastructure (including pumps and distribution networks) and may even impact upon the produce. Sediment also has negative impacts on domestic water supplies, causing problems in both water treatment plants and distribution networks. Failure of water treatment plants, especially in poor regions, can mean that the water is unsuitable for human consumption. As a result populations may suffer from health problems.
4. **Flooding:** Flooding occurs when a watercourse is unable to convey the quantity of runoff flowing downstream. The frequency with which this occurs is described by a return period. Flooding is a natural process, which maintains ecosystem composition and processes, but it can also be altered by land use changes including river engineering. Increased sediment accumulation in river systems can raise the level of the riverbed, subsequently increasing water levels. This deposition can have significant implications for flooding, and may cause floods to pose a risk to human settlements which would otherwise be contained by banks and levees.

5. **Navigational Issues:** The sedimentation of water courses can also make them unsuitable for navigation without regular dredging work. This dredging is often costly to operate.
6. **Impacts on Wetlands and In-stream Ecosystems:** Where dams do not exist to trap sediment, excessive sediment inputs may have negative impacts on wetland areas. This is especially the case where wetlands occur close to agricultural areas and where land use change has resulted in increased rates of soil loss, increased downstream sediment loads and increased rates of sedimentation in wetland areas. The impact of excessive sediment deposition in wetlands may create ecological disruption. Sedimentation results in alteration of aquatic food webs, nutrient cycling and biogenic processes that transform and sequester pollutants. Eventually sediment deposition may entirely smother wetlands resulting in limited biological diversity.
7. **Impacts on Water Quality (Turbidity and Sediment-associated Pollutants):** Sediment is a pollutant in its own right. Even where sediment is uncontaminated by agricultural fertilizers and pesticides and industrial or human waste, they cause turbidity in the water which limits light penetration and prohibits healthy plant growth on the river bed. The accumulation of sediments on the river bed can smother or disrupt aquatic ecosystems by reducing food sources, and degrading spawning grounds (such as gravel and rocky environments) and the habitats of desirable fish species. Turbidity may also result in eutrophication where nutrient rich sediments are present (particularly sediments from agricultural land with high fertilizer contents). Eutrophication creates a situation where the dissolved oxygen present in the water system is reduced and the fish species may be unable to survive in the water column. Eutrophication, where it results from toxic algal blooms, can also be a serious risk to human health. Sediments in areas with high human activity often contain chemical pollutants which may pose a risk to human health and the health of surrounding ecosystems. Potable water supplies can be compromised by the presence of excess sediment (whether contaminated by toxins or not) as purification facilities may not be able to cope with the sediment in the water leading to temporary breakdowns and subsequent risks to the safety of the drinking water. Contaminated surface waters also cause a risk by altering the metabolic processes of the aquatic species that they host. These alterations can lead to fish kills or alter the balance of populations present. Other specific impacts are on animal reproduction, spawning, egg and larvae viability, juvenile survival and plant productivity.



Lesson 20 Sediment Transport and Measurements

Transport of particles in flowing water takes place through sliding, rolling, saltation and suspension. Different mechanisms of transport are discussed below.

20.1 Mechanics of Sediment Transportation

The four modes of particle transport in water are sliding, rolling, saltation and suspension. Sliding particles remain in continuous contact with the bed, merely tilting to and fro as they move. Rolling grains also remain in continuous contact with the bed, whereas saltation grains 'jump' along the bed in a series of low trajectories. Sediment particles in these three categories collectively form the *bed load*. The suspended load consists of particles in suspension. These particles follow long and irregular paths within the water and seldom come in contact with the bed until they are deposited when the flow slackens. Sliding and rolling are prevalent in low velocity flows, whereas; saltation and suspension take place in high velocity flows. The region of flow influenced by proximity to the surface is called the *boundary layer*. A boundary layer develops wherever a fluid moves over a surface.

The friction between flowing water and the bed generates a boundary layer in which turbulent flow is dominant, except very close to the bed. Movement of sediment (erosion) occurs when the shear stress generated by the frictional force of water flowing over the sediment overcomes the force of gravity acting on the sediment grains and the friction between the grains and the underlying bed. Shear stress is proportional to the square of the mean current speed (and to the density of the water. Movement of grains of a given size begins when the shear stress at the bed reaches a critical value (critical shear stress).

Cohesive sediments contain a high proportion of fine-grained clay minerals and are more difficult to erode than non-cohesive sediments, which often consist mostly of quartz grains. For cohesive sediments, the smaller the particle size, the greater the water velocity required to erode them. Once in suspension, clay particles are transported for long distances by the currents that would be much too weak to erode them. Shear stress is proportional also to the velocity gradient in the boundary layer and to the viscosity of the water.

20.2 Types of Sediments Transported Along with Streams

Sediment transport is the movement of solid particles (sediment), typically due to a combination of the force of gravity acting on the sediment, and/or the movement of the fluid in which the sediment is entrained. An understanding of sediment transport is typically used in natural systems, where the particles are clastic rocks (sand, gravel, boulders, etc.), mud, or clay; the fluid is air, water, or ice; and the force of gravity acts to move the particles due to the sloping surface on which they are resting.

Sediment movement in streams and rivers takes two forms. Suspended sediment is the finer particles which are held in suspension by the eddy currents in the flowing stream, and settle out only when the stream velocity decreases, such as when the streambed becomes flatter, or the stream discharges into a pond or a lake. Larger solid particles are rolled along the streambed and are called the bed load. There is an intermediate type of movement where particles move downstream in a series of bounces or jumps, sometimes touching the bed and sometimes carried along in suspension until they fall back to the bed. This is called

movement in saltation, and is a very important part of the process of transport by wind, but in liquid flow the height of the bounces is so low that they are not readily distinguished from rolling bed load.

Sediment transport is a direct function of water movement. During transport in a water body, sediment particles become separated into three categories: suspended material which includes silt + clay + sand; the coarser, relatively inactive bed load and the saltation load.

20.2.1 Bed Load

Bed load is the clastic (particulate) material that moves through the channel fully supported by the channel bed itself. These materials, mainly sand and gravel, are kept in motion (rolling and sliding) by the shear stress acting at the boundary. Unlike the suspended load, the bed-load component is almost always capacity limited (i. e. a function of hydraulics rather than supply). A distinction is often made between the bed-material load and the bed load.

Bed-material load is that part of the sediment load found in appreciable quantities in the bed (generally > 0.062 mm in diameter) and is collected in a bed-load sampler. The bed material is the source of this load component and it includes particles that slide and roll along the bed (in bed-load transport) but also those near the bed transported in saltation or suspension phase. Bed load, strictly defined, is just that component of the moving sediment that is supported by the bed (and not by the flow). The term "bed load" refers to a mode of transport and not to a source. Since bed load consists of stony material (gravel and cobbles), it moves by rolling along the bed of a river because it is too heavy to be lifted into suspension by the current of the river. Bed load is especially important during periods of extremely high discharge and in landscapes of large topographical relief, where the river gradient is steep (such as in mountains). It is rarely important in low-lying areas. The portion of the sediment load that is transported along the bed by sliding, rolling or hopping can be termed as the bed load. Bed load moves at velocities slower than the flow and spends most of its time on or near the stream bed. In many streams, grains smaller than $1/8$ mm are always suspended while grains great than 8 mm travel as bed load. The strength of flow determines the transport mechanism of grains in between these two sizes. Sediment transport can also be categorized based on the source of the grains: 1) bed material load, which is grains found in the stream bed; and 2) wash load, which is finer grains found as less than a percent or two of the total amount in the bed.

20.2.2 Suspended Load

Suspended load consists of sediment particles that are mechanically transported by suspension within a stream or river. This is in contrast to bed or traction load, which consists of particles that are moved along the bed of a stream and dissolved load which consists of material that has been dissolved in the stream water. In most streams, the suspended load is composed primarily of silt and clay size particles. Sand-size particles can also be part of the suspended load if the stream flow velocity and turbulence are great enough to hold them in suspension.

The suspended load can consists of particles that are intermittently lifted into suspension from the stream bed and of wash load and also those which remains continuously suspended unless there is a significant decrease in stream flow velocity. Wash load particles are finer than those along the stream bed, and therefore must be supplied by bank erosion, mass wasting, and mass transport of sediment from adjacent watersheds into the stream

during rainstorms. Water density is proportional to the amount of suspended load being carried. Muddy water high in suspended sediment will therefore increase the particle buoyancy and reduce the critical shear stress required to move the bed load of the stream.

Suspended load comprises sand + silt + clay sized particles that are held in suspension because of the turbulence of the water. The suspended load is further divided into the wash load which is generally considered to be the silt + clay sized material ($< 62 \mu\text{m}$ in particle diameter) and is often referred to as “fine-grained sediment”. The wash load is mainly controlled by the supply of this material (usually by means of erosion) to the river. The amount of sand ($> 62 \mu\text{m}$ in particle size) in the suspended load is directly proportional to the turbulence and mainly originates from erosion of the bed and banks of the river. In many rivers, suspended sediment (i.e. the mineral fraction) forms most of the transported load. Particulate sediment that is carried in the body of the flow is of the following types.

1. Suspended load moves at the same velocity as the flow.
2. The *Hjulstrom curve* shows that a much higher velocity is required to entrain clay and fine silt than coarse sand. However, once the fine sediment is in suspension, a much lower velocity is required to maintain it in suspension.
3. The quantity and quality of the load is defined in terms of competence and capacity. Competence is the large size clast that a stream can carry, whereas capacity is the volume of sediment carried. Competence (caliber) is a function of velocity and slope whereas capacity is a function of velocity and discharge.
4. A small particle (e.g. clay and fine silt), with a large relative surface area, is held in suspension more easily because of the electrostatic attraction between the unsatisfied charges on the grain's surface and the water molecules. This force, tending to keep the particle in the flow, is large compared to the weight of the particle.

20.2.3 Wash/Dissolved Load

Although wash load is part of the suspended-sediment load it is useful to make a distinction. Unlike most suspended-sediment load, wash load does not rely on the force of mechanical turbulence generated by the flowing water to keep it in suspension. It is so fine (in the clay range) that it is kept in suspension by thermal molecular agitation. Because these clays are always in suspension, wash load is that component of the particulate or clastic load that is “washed” through the river system. Unlike coarser suspended-sediment, wash load tends to be uniformly distributed throughout the water column and therefore moves with the mean velocity of main stream. That is, unlike the coarser load, it does not vary with height above the bed.

Wash load concentrations are approximately uniform in the water column. This is described by the end member case in which the Rouse number is equal to 0 (i.e. the settling velocity is far less than the turbulent mixing velocity), which leads to a prediction of a perfectly uniform vertical concentration profile of material. The Rouse number is a ratio of sediment fall velocity to upward velocity.

Dissolved load is the term for material; especially ions from chemical weathering that are carried in solution form by a stream. The dissolved load contributes to the total amount of material removed from a catchment. The amount of material carried as dissolved load is typically much smaller than the suspended load, though this is not always the case. Dissolved load comprises a significant portion of the total material flux out of a landscape,

and its composition is important in regulating the chemistry and biology of the stream. Factors that govern the percentage of dissolved and suspended loads in the flowing streams include:

1. Climate: Temperature, Precipitation, Vegetation.
2. Vegetation: Type and Amount.
3. Activity by Man: Mining, Construction, Clear Cutting, etc.
4. Rock Solubility: e.g. Hard Water in Carbonate Terranes.
5. Erodibility of Materials in the Drainage Basin.
6. Relief and Slope.

20.3 Methods of in Stream Sediment Measurements

There are different methods for stream sediment measurements: such as bed load, suspended load, wash load, dissolved load and saltation load measurements.

20.3.1 Bed Load-Measurements

Bed load gauging (also called bed load transport measurement) is often mixed up with bed material sampling. Bed load gauging is the measurement of the amount of sediment that is moving as “bed load”, i.e. rolling, sliding and bouncing (in “saltation”) on or over the stream bottom, while bed material sampling is the collection of the material comprising the stream bottom. Bed load is extremely difficult to measure directly because the measuring instrument (bed load sampler) invariably interferes with the flow. Most bed load movement occurs during periods of high discharge on steep gradients when the water level is high and the flow is extremely turbulent. Such conditions also cause problems for field measurements.

A commonly used type of bed-load sampler is shown in Fig. 20.1. In small streams where the sampler can often be placed on the bed so that it is appropriately oriented towards the flow, the sample collected may be meaningful although there is always some bed scour at the inlet that distorts the actual bed-load transport in the vicinity of the instrument. In large rivers where the sampler must be lowered from a boat by cable to an unseen bed, measurements can be highly inaccurate and must be repeated many times before reliable results can be obtained. The problems relate largely to the fact that the operator is unable to see the position of the sampler on the bed. If the sampler settles on a boulder or dune face, for example, it may push the sampler inlet into the bed and as a result the sampler may drastically over sample the rate of bed-load transport. At other times the sampler position and the bed morphology may be such that scouring of the bed at the sampler inlet could be severe leading to over sampling.



Fig. 20.1. A Commonly Used Type of Bed-load Sampler.

When the bed-load sampler is appropriately oriented towards the flow direction, bed-load material enters the sampler through the inlet and the divergent flow within the sampler reduces the flow velocity, allowing the sediment to accumulate. A fine mesh provided at the rear of the sampler allows the incoming water but not the bed-load sediment to pass through. After an appropriate measured time-interval the sampler is taken out and the trapped sediment is removed for weighing.

A different problem during sampling occurs if the bed-load sampler settles on the back of a dune or perhaps the front of the sampler settles on an object that keeps the inlet from contacting the bed. For these reasons river scientists often prefer to rely on other methods to estimate bed-load transport rates in rivers. Methods other than direct measurement by bed-load sampler include:

1. Bed-load Pits or Traps

These are the installations that divert sediment from a channel and convey it to a measurement facility where it is weighed and then returned once again to the channel so that the sediment-transport system is not unduly disrupted. Obviously such a facility is expensive to build and operate and there are few of them. The main purpose of such a facility is to calibrate bed-load transport equations for use on other river channels.

2. Morphological Methods

a) Bed Form Surveys

Where bed-material is moving as bedforms such as dunes, bedform surveys can be used to track the downstream movement of sediment. This technique relies on high-resolution sonar imaging of the river bed to construct profiles that can be differenced to determine the volumetric bed-load sediment transport rate.

b) Channel Surveys

Channel surveys can be used to produce sequential morphologic maps of a reach of river that can be differenced (using GIS) to yield amounts of erosion and deposition over time. The principle here is the same as that for bedform surveys but in this case involves the entire three-dimensional channel morphology. Like the bedform-based calculation, differencing channel morphology as a basis for calculating bed-load sediment transport relies on the assumption that there is no sediment throughput. That is, all transported bed-load is involved in local deposition and erosion and not simply transported through the reach without contributing to the changing channel morphology

c) Sedimentation-zone Surveys

Sedimentation-zone surveys are one of the most reliable methods of determining representative long-term bed-load transport rates in rivers. This morphologic method relies on measuring the accumulating sediment in a feature such as a delta that a river is gradually building into a lake or embayment

20.3.2 Suspended Load-measurements

The simplest way of taking a sample of suspended sediment is to dip a bucket or other container into the stream, preferably at a point where the sediment is well mixed, such as downstream from a weir or rock bar. The sediment contained in a measured volume of water is filtered, dried and weighed. This gives a measure of the concentration of sediment and when combined with the rate of flow gives the rate of sediment discharge. For determining suspended sediment load, it is necessary to consider all particle sizes (sand + silt + clay). Therefore, a depth-integrating sampler must be used to ensure that the depth-dependent sand-sized fraction is correctly sampled. There are two generally accepted methods for measuring suspended sediment concentration for load determination as described below:

1. Equal-discharge-increment Method: This method requires that at first a complete flow measurement be carried out across the cross section of the river. Using the results, the cross-section should be divided into five (more on large or complex rivers) intervals (i.e. vertical sections) having almost equal discharge in each interval. The number n of the intervals is selected based on experience. Depth integrated suspended sediment sampling is carried out at one vertical within each of the equal-discharge-intervals, usually at a location most closely representing the centroid of flow for that interval. The sediment concentration for each equal-discharge- interval should be measured. The mean discharge-weighted suspended sediment concentration (SS_c) should be obtained by taking the average of the concentration values C obtained for each interval i .

$$SS_c = \frac{\sum_{i=1}^n C_i}{n} \quad (20.1)$$

The discharge-weighted suspended sediment load (SSL), in tonnes per day, for the river cross-section have to be obtained by multiplying the concentration, C in ppm (mg/l) by the discharge, Q , in m^3/s of each equal-discharge-interval, i and summing for all the intervals. This method is very time-consuming, but is the most used by the sediment recording agencies.

$$SS_L = \sum_{i=1}^n (C_i Q_i) \times 0.0864 \quad (20.2)$$

2. Equal-width-increment Method: This method is used without making flow measurements and is usually used in small to medium rivers and especially rivers that are shallow enough for wading. The operator marks off 10-20 equal intervals across the river cross-section. At the deepest point, the operator takes a depth-integrated sample, noting the transit rate of the sampler (i.e. the uniform speed at which the sampler is lowered, then raised to the surface). Using that same transit rate, a suspended sediment sample is taken at each of the intervals. Because each vertical will have a different depth and velocity, the sample volume will vary with each vertical sampled. Care should be taken to see that the bottle is never over-filled. All samples are collected in a single container which is then agitated and sub-sampled, usually two or three times and analysed for suspended sediment concentration. The average of these values is the mean cross sectional suspended sediment concentration. In this method, the results are corrected for differences in discharge at each section caused due to the same transit rate (and the same nozzle diameter) used at all sections although a shallow section with less discharge produces a proportionally smaller suspended sediment sample than a deep section having a higher discharge.

For suspended sediment quality, where the primary interest is the chemistry associated with the silt + clay (< 0.63 μm) fraction, sampling can be greatly simplified because this fraction is not normally depth dependent. While there are no universally accepted rules for sampling, many scientists collect a grab sample from a depth of 0.5 m at the point of maximum flow in the cross-section. For larger rivers, or rivers where there is concern over cross-sectional variation, grab samples can be taken from several locations across the section. For more precise work where accurate loads are required, especially for micro-pollutants, sampling should be carried out using either of the methods mentioned above. It is particularly important to avoid sampling near river banks (or lake shores) where elevated concentrations of suspended matter occur and which are often contaminated by garbage and other anthropogenic materials.



Lesson 21 In-stream Sediment Measurements

In-stream sediment measurement is very important as most precise information on sediment flow can be obtained from this measurement. Different techniques followed for this measurement are discussed in this chapter.

21.1 Location of Measurement

When the question 'where to measure' comes to our mind the most obvious answer in a broader sense is where the data can be collected, however the answer is not so simple. It becomes quite complex when sediment concentrations or loads of an entire large area need to be characterized which largely depends on the information wanted and the particular situation being studied. Generally, measurements should be made downstream as close as possible to the area of disturbance. The effect of a sediment-producing condition is attenuated and its effect is confounded with the effects of dilution and other sediment sources farther downstream. If the downstream effects of a disturbance are being studied, it is better to measure at the affected site.

The location of measuring station also depends on the hydraulic conditions in the stream. In some streams, control can be affected by geology or large organic debris. Bedrock cropping out at the crest of major riffles or falls can provide excellent control in natural channels. In some situations, well emplaced logs stabilize the channels and provide suitable locations to measure both the suspended sediment concentration and discharge. Along with location, depth is the other factor which affects the concentration of sediment in the streams i.e. near the stream bed it is more, in the middle relatively less, while on the top of the surface it is too less. Thus it is very difficult to select the sampling point, which can accurately define the sediment concentration in vertical cross-section of stream.

21.2 Frequency of Measurement

Frequency of sampling depends upon the sediment concentration in the stream flow. It is well known that the sediment concentration increases rapidly on the rising phase of the hydrograph than the falling phase. Therefore, sediment samples should be collected more frequently at the beginning of runoff and it should be continued up to the peak stage of runoff. The sample should be taken at every 15 minutes interval.

21.3 Number of Monitoring Stations

In most of the cases the entire runoff of the watershed is drained from a single point known as the outlet, the collection of the sediment sample should be carried out from the outlet point. The outlet is an ideal location of monitoring station for the entire watershed. Similarly, in case of drainage system, where flow is drained from more than one points, gauging station should be provided at each outlet point for sampling.

21.4 Observation and Collection of Sediment Samples

There are several methods which are used today for evaluation of sediment transport in rivers. The total number of sampling points (Table 21.1) to be considered for collecting the sediment samples depends on the width of the stream flow.

Table 21.1. Number of Sampling Points in the Stream.

Width of Stream (m)	No. of Sampling Points	Location of Point from Site
< 30	3	25, 50 and 75% of the stream width
30 - 300	5	25, 35, 50, 65 and 80% of the stream width
> 300	7	15, 30, 40, 50, 60,70 and 85% of the stream width

Apart from width-wise sediment sampling, the depth-wise sampling is also carried out using the following points:

1. In case of single point sampling, the sample should be collected from the depth of 0.6 d, measured from the surface (d = the depth of the stream).
2. In case of double point sampling, one sample should be collected from the point near the top of water surface i.e. at a depth of about 0.2 d and other near the stream bed at about 0.8 d. The concentration of sediment is weighted equally.
3. For three point sampling: one sample should be taken near the top of water surface, second from mid depth of stream and the third near the stream bed, and weighted equally.
4. Similarly, in case of multiple sampling, there should be several samples from several points of vertical section of the stream flow. This helps to elaborate the sediment distribution in the stream.
5. The sediment sampler should be kept in vertical position from the stream bed.
6. The mouth of the sampler should be opened after reaching the desired depth of stream flow.
7. Whenever it is expected that the distribution of sediment is uniform in the stream flow, sampling should be done only at 0.6d of the stream flow.

21.5 Estimation of Different Loads from Samples

Bed load is not amenable to theoretical treatment. The following two methods are generally used for estimation of bed load.

1. Analytical Method
2. Stream Sampling

1. Analytical Method: Computation of bed-load movement using analytical method involves several relations; these relations can be empirical or analytical. The derivation of the relation is done based on the following two basic concepts:

- 1) A minimum fluid force is exerted on the soil particles before initiating their movement.
- 2) The force exerted by the soil particles on the channel bed is not constant, but varies about some mean value. This concept is based on the theory of turbulent flow.

The different forces acting on the soil particles of non-cohesive material are basically the gravity and fluid forces. The analytical method for computing the bed load transport involves several empirical relations. Few of them are described as under:

Du Boys Formula: This formula is based on the theory of tractive force, which was derived on the assumptions that the coarser particles are moved in the form of layers and subject to uniform tractive force and vertical velocity gradient of the moving coarser particles is linear. The formula for bed load estimation is written as under:

$$q_s = C_s \tau_o (\tau_o - \tau_c) \quad (21.1)$$

where, q_s = rate of bed load transport (volume per second per unit stream width); $C_s = \frac{0.173}{d^{3/4}}$, coefficient, depends upon the shape and size of the sediment particle = $\frac{0.173}{d^{3/4}}$, where d is the grain diameter (mm); T_o = average shear stress exerted on the channel boundary and T_c = critical shear stress.

An estimate of the average boundary shear stress (T_o) exerted by the fluid on the bed is:

$$\tau_o = \gamma D S_f \quad (21.2)$$

where, γ = the specific weight of water, D = the flow depth (\sim hydraulic radius), and S_f = the friction slope.

And the estimate of Critical shear stress (τ_c) can be defined by equating the applied forces to the resisting forces. For soil grains of diameter d and angle of repose ϕ on a flat bed, the following relations can approximate the critical shear for various sizes of sediment:

For clays,

$$\tau_{cr} = 0.5 (\lambda_s - \lambda_w) d \tan \phi \quad (21.3)$$

For silts and sands,

$$\tau_{cr} = 0.25 d_*^{-0.6} (\lambda_s - \lambda_w) d \tan \phi \quad (21.4)$$

For gravels and cobbles,

$$\tau_{cr} = 0.06 (\lambda_s - \lambda_w) d \tan \phi \quad (21.5)$$

where,

$$d_* = d \left[\frac{(G-1)g}{\nu^2} \right]^{\frac{1}{3}} \quad (21.6)$$

And λ_s = the unit weight of the sediment; λ_w = the unit weight of the water/sediment mixture; G = the specific gravity of the sediment; g = gravitational acceleration; ν = the kinematic viscosity of the water/sediment mixture

Shield's Formula: Shield's formula is applied for estimating the bed load movement consisting of uniform size of sediments. The equation was derived by considering the effect of specific gravity of the sediment. The Shield's formula is written as:

$$\frac{q_s S_s}{q_s} = 10 \frac{(\tau_o - \tau_c)}{\gamma (S_s - 1) d} \quad (21.7)$$

where, S_s = specific gravity of sediments, such as stone grains; S = stream bed slope (mm); q_s = discharge rate (m³/s per unit width of stream); q = discharge per unit channel width; γ = specific gravity of the fluid; d = diameter of sediment (mm).

Mayer Peter's Formula: This was developed based on the effect of grain diameter, slope of channel bed and discharge characteristics of flow on bed load movement. It is written as:

$$G_s = 4700 \left[\tau_o \left(\frac{N'}{N} \right)^{\frac{3}{2}} - \tau_c \right]^3 \quad (21.8)$$

where, G_s = rate of bed load transport per unit width of channel (kg/h.m); N = Manning's roughness coefficient for plain bed = $\frac{1}{n}$, in which d is the effective grain diameter; N' = actual value of Manning's roughness coefficient for rippled bed. Generally, the value of N' is taken as 0.020 for discharge of more than 11 m³/s and 0.0225 for a lower discharge value; τ_o = unit

tractive force exerted by flowing water = $0.97 \cdot RS$; = critical shear stress required to displace the sediments = $0.07 d$, kg/m²; R = hydraulic mean depth and S = stream bed slope.

Chang Formula: Chang proposed the following formula for estimating the bed load:

$$Gi = \frac{kn}{\tau_c^2} \tau_o [\tau_o - \tau_c] \quad (21.9)$$

where, Gi = rate of bed-load transport in pounds/second/unit width; k = constant; n = Manning's roughness coefficient; τ_o = unit tractive force due to stream water flow, τ_c = critical shear stress required to displace the sediment = $0.0175 (1.65 d)^x$ when specific gravity of the sediment is 2.65; in which, d is sediment diameter (mm); x = exponent which is either equal to unit or half, depending upon whether the value of $1.65 d$ is greater or less than unity respectively.

Schoklitsch Formula: This formula was developed based on experimental data, obtained by installation of flume in the stream. The *Schoklitsch formula* assumes that the bed-load contains the materials of uniform size.

The formula may be written as:

$$Gi = \frac{4.37}{\sqrt{d}} S^{1.5} [q - q_c] \quad (21.10)$$

where, Gi = rate of bed-load transport (F.P.s) (kg/s); d = particle diameter (m); S = slope of stream bed; q = observed discharge (m³/s); q_c = critical discharge (m³/s); it is given

by $\frac{0.00021d}{S^{\frac{4}{3}}}$.

2. Stream Sampling [Bed Load Sampling]

The estimation of rate of bed load movement through the stream flow is carried out by placing the sampler over the bed and measuring the amount of materials collected for a given time. The samplers used for collecting the bed load sample are known as bed load samplers. The sampler is kept in position by a rod, when the depth of stream flow is low or by a cable from the boat, from a trolley or pulley running on a cable spanned across the river or from a bridge. The lowering and raising of the sampler is done with the help of a winch. Based on the construction and principles of operation, bed-load samplers are of different types. They are:

1. Basket Type
2. Tray or Pan Type
3. Pressure Difference Type

For estimating the bed load, the samples collected through the samplers are dried and weighted. The dry weight is then divided by the time taken for measurement and width of

the stream bed to get the bed load movement per unit stream width per unit time. A curve between the rate of movement and stream flow can also be drawn. From this rating curve, the rate of bed load movement for different discharges of the stream can be determined. This is usually practiced as continuous discharge measurement using stage level recorder is much easier compared to continuous monitoring of bed load.

Bed load is the sum of saltation load and surface creep. It is obtained either by using bed load samplers or can be computed by using several formulae. In case, the measurement of bed load is not possible due to some unforeseen reasons, then depending upon bed load materials, an amount ranging from 2.5% to 15% of suspended load is added to the suspended load as bed load to get the amount of sediment load transported by stream flow.



Lesson 22 Reservoir Sedimentation

Reservoirs are constructed by incurring a huge sum of capital expenditure. Therefore, they should provide service with a long useful life. Sedimentation is a big problem as it reduces the life of the reservoir considerably. Therefore, it is essential to know the sedimentation process in the reservoirs to evolve some strategy to tackle the problem.

22.1 Distribution of Sediments in Reservoirs

The integrated development of river basin also involves the construction of storage body i.e. reservoir for solving the problems of irrigation, power generation, flood control etc. The sedimentation is one of the main problems in reservoir operation. The problem should be essentially considered in the design and maintenance of reservoirs, because deposition of sediments in the reservoirs reduces their net storage capacity. The sedimentation process starts in the reservoir due to the fact that as river water enters the storage area, the velocity of flow is reduced due to increased cross-sectional area of the channel. In course of sedimentation, if water already stored in the reservoir is clear and the inflow is muddy, then these two fluids of different densities involve different velocities. The turbid water tends to flow along the channel bed towards the dam due to gravity force. This type of flow is referred as stratified flow and the under flow is called as density current. Basically, the density currents are the gravity flow. All these processes of sediment deposition in the reservoir refer to the reservoir sedimentation.

In reservoir design, allowance for deposition of sediment must be provided. The volume of reservoir which is to be used for irrigation, power generation etc., is called as *live storage*; it should be fixed after providing allowance for sediment deposition. On the basis of observations taken from several existing reservoirs, it has been found that the major portion of sediments get deposited in the live storage part, which greatly affects the functioning of the reservoir. The knowledge on the distribution pattern of sediments in the reservoir plays an important role in its planning and design.

1. It provides an idea about how sediments tend to deposit near the dam during a given time period, on the basis of which the levels of outlet for water flow and penstock gates etc. can be decided.
2. The allocation of the various storages of reservoir is carried out, on the basis of distributed silts throughout the reservoir depth.
3. It helps to determine the region of delta formation in the reservoir and thereby increase in back water level.
4. The sediment distribution pattern also helps to decide the sites for locating the recreational facilities such as swimming, boating areas etc.

All reservoirs formed by dams on natural water courses are subject to some degree of sediment inflow and deposition. The problem confronting the project planner is to estimate the rate of deposition and the period of time before the sediment will interfere with the useful function of the reservoir. Provisions should be made for sufficient sediment storage in the reservoir at the time of design so as not to impair the reservoir functions during the

useful life of the project or during the period considered as the minimum economic life. There are a series of basic steps to be followed in studying the sedimentation processes in reservoirs. First, sediment transported by the upstream river system into a reservoir is deposited and/or transported at a reduced rate further into the reservoir, the distance being dependent on the decreased water velocities. As sediment accumulates in the reservoir, storage capacity is reduced. The continued deposition develops distribution patterns within the reservoir which are greatly influenced by both operations of the reservoir and timing of large flood inflows. Deposition of the coarser sediments occurs in the upper or delta reaches while finer sediments may reach the dam and influences the design of the outlet works. A major secondary effect is the downstream degradation of the river channel caused by the releases of clear water.

Sedimentation processes in a reservoir are quite complex because of the wide variation in the many influencing factors. The most important being (1) hydrological fluctuations in water and sediment inflow, (2) sediment particle size variation, (3) reservoir operation fluctuations and (4) physical controls or size and shape of the reservoir. Other factors that may be quite important for some reservoirs are: vegetative growth in upper reaches, turbulence and/or density currents, erosion of deposited sediments and/or shoreline deposits, and operation for sluicing of sediment through the dam.

22.2 Distribution and Estimation of Reservoir Sedimentation

Sediment is the end product of erosion or wearing away of the land surface by the action of water, wind, ice and gravity. Water resource development projects are most affected by sediment transported by water. The total amount of onsite sheet and gully erosion in a watershed is known as the *gross erosion*. However, all the eroded material does not enter the stream system; some of the material is deposited at natural or manmade barriers within the watershed and some may be deposited within the channels and their flood plains. The portion of the eroded material which travels through the drainage network to a downstream measuring or control point is referred to as the *sediment yield*. The sediment yield per unit of drainage area is the *sediment yield rate*. Most methods for predicting sediment yields are either directly or indirectly based on the results of measurements. Direct measurements of sediment yields are considered the most reliable method for determination of sediment yields. This is accomplished by either surveying of reservoirs or sampling the sediment load of a river. Both the methods are described in the subsequent sections. Other methods for predicting sediment yields depend on measurements to derive empirical relationships or utilize empirically checked procedures such as the sediment yield rate weighting factors or the Universal Soil Loss Equation (USLE). Sediment yield rate factors are the factors which determine the sediment yield of a watershed and they can be summarized as follows:

1. Rainfall amount and intensity, Soil type and geologic formation,
2. Ground cover,
3. Land use,
4. Topography,
5. Upland erosion (nature of drainage size, and alignment of channels),
6. Runoff,

7. Network-density, slope, shape, sediment characteristics such as grain size, mineralogy, etc. and
8. Channel hydraulic characteristics.

Gross erosion includes sheet, rill and gully erosion. In the small drainage basins, sheet and rill erosions are the major source of reservoir sediments. The USLE and the Musgrave equation are commonly used to compute the sheet and rill erosion. These equations were derived by empirical methods from small experimental plot data. The universal soil loss equation is:

$$A = RKLSCP \quad (22.1)$$

where, A = the average annual soil loss (tons per ha) predicted by the equation; R = the rainfall factor; K = the soil erodibility factor (tons per ha per year); LS = the length and steepness of slope factor; C = the cropping and management factor; and P = the supporting conservation practice factor (terracing, strip cropping, and contouring).

The Musgrave equation is as follows:

$$E = I \frac{R'}{100} \left(\frac{S}{10} \right)^{1.35} \left(\frac{L}{72.6} \right)^{0.35} \left(\frac{P_{30}}{1.25} \right)^{1.75} \quad (22.2)$$

where, E = the sheet and rill erosion (inches per year); I = the erosion from continuous row crop from the given soil (adjusted to 1.25 inches rainfall) in inches per year; R' = the cover factor (fallow or continuous row crop equals 100); S = the degree of land slope in percent (with 10% as standard); L = the length of land slope in feet (with 72.6 feet as standard); P_{30} = the maximum 30-minute rainfall amount, 2-year frequency, in inches (with 1.25 inches as standard). The factor, I , was not available for the soils used in this study. The equation was modified by substituting the product '0.59 KR ' for I and by adding the practice factor P , both from the universal soil loss equation. The product KR is the soil loss from continuous fallow. Thus, multiplying the product KR by 0.59, the soil loss from continuous row crop is obtained which is comparable to the soil loss given by I . The term $[P_{30}/1.25]^{1.75}$ was dropped because rainfall is included in the R factor. Assuming the average volume-weight of the upland soils as 150 tons per acre-inch, the modified equation becomes:

$$E' = \frac{0.59}{150} KR \frac{R'}{100} P \left(\frac{S}{10} \right)^{1.35} \left(\frac{L}{72.6} \right)^{0.35} \quad (22.3)$$

where E' is the sheet and rill erosion in inches per year.

22.3 Factors Affecting the Sedimentation of Reservoirs

Sedimentation is the process of letting suspended material settled by gravity. Suspended material may be particles, such as clay or silts, originally present in the source water. Sedimentation occurs due to the decrease in velocity of the water to a point below which the particles will no longer remain in suspension. When the velocity no longer supports the

transport of the particles, gravity will remove them from the flow. Several factors affect the sedimentation of reservoirs. Some of the more common types of factors to be considered are:

1. **Slope of Stream:** The deposition of the sediment takes place in the bottom portion, of the reservoir which are constructed on a stream having steep slope and longer reach whereas, deposition of the sediment takes place in higher elevation of the reservoir which are constructed on the stream with flat slope.
2. **Reservoir Length:** The distribution of sediment in the reservoir is affected greatly by its length. It has been observed that the large size sediment is deposited in the lower portion of the reservoir for a shorter length and the smaller size sediment is deposited at the higher elevation of the reservoir for longer length.
3. **Reservoir Constriction:** If there is constriction in the reservoir, the deposition of the sediment takes place in the upper portion comparatively in large proportion. The sediment deposition pattern is flatter in the constricted portion but it does not follow the natural slope of the stream.
4. **Size of Sediment:** The size and type of particles have a significant effect on the sedimentation. Because of their density, sand or silt can be removed very easily. The velocity of the water-flow in stream is slowed down as soon as they enter into the reservoir, and most of the gravel and grit settle down by simple gravitational forces.
5. **Capacity Inflow:** The capacity inflow is one of the most important factors which play a great role in the distribution pattern of sediment in the reservoir. A small reservoir in a large size river passes most of the finer particles along the inflow very quickly into the storage area, they do not get the time to settle down in the reservoir but they are disposed off downstream. In case of large reservoirs, the water for a long time resulting into complete deposition of suspended sediments.
6. **Vegetal Growth:** vegetal growth on the upstream part of the reservoir and in nearby areas helps in trapping the sediments and thus affecting the entry of silts in large amount into the reservoir.
7. **Reservoir Operation:** The reservoir operation technique greatly affects the pattern of sediment deposition. The reservoir may be operated for single purpose and for multipurpose both. Single purpose reservoir operations are generally performed relatively at constant level and as such the primary patterns of sediment deposition is not much affected. But in case of multipurpose reservoirs, the operation is conducted within a wide range of elevations to fulfill the various demands, throughout the year. It causes significant variations in the primary sediment distribution pattern, because it flushes down some deposited sediments from live storage of the reservoir at higher elevation due to seasonal reduction in the reservoir water level.
8. **Inflow Patterns of the Stream:** A stream, in which flood occurs during the early part of the monsoon, the amount of sediment reaching the reservoir being more tends to settle down in the reservoir. But when major flood occurs during the later part of the monsoon period, a reverse trend is obtained.
9. **Sediment Load in River Flow:** The amount of sediment load carried by the river flow varies greatly both in quantity and quality, depending on the watershed characteristics with regard to the land use as well as the climatic conditions. In addition, trapping of sediment is a function of retention period, which is reduced

with the age of reservoir. The sedimentation pattern in the reservoir is greatly affected by these variations.

10. **Shape of Reservoirs:** The shape of a reservoir also plays a key role in sediment distribution pattern. For example in a reservoir of regular shape, the suspended sediment tends to deposit uniformly over the bed along the direction of flow, with decreasing depth away from the dam. But there would be a large variation in the depth of sediment deposition at the bottom, if the shape of reservoir is irregular.
11. **Outlets:** If the outlet of the reservoir has adequate capacity and is located at lower elevation then the density current tends to pass out very rapidly. As a result the deposited sediment mixed in the density current near the dam of the reservoir is removed.
12. **Sediment-reservoir Volume Ratio:** If the inflow volume of water and sediment is large compared to the reservoir volume, water cannot be retained in the reservoir for a longer period. In that case deposition of the percentage of inflow sediment will be much less as the retention period is low.

22.4 Rate of Reservoir Sedimentation- Sediment Delivery Ratio, Trap Efficiency

Rate of reservoir sedimentation depends not only on the volume of reservoir inflow into the reservoir but also on the trap efficiency.

22.4.1 Trap Efficiency

There are a large number of reservoirs in the world which have been built for different purposes like water supply, irrigation, and flood control or for controlling downstream water quality. The reduced flow velocity in these water storage structures causes sedimentation of the transported particles. For most of the storage structures this is a drawback as their retention capacity decreases due to sedimentation processes. Sediment volumes in small ponds can be used to reconstruct sediment yield values and to study the spatial variation in sediment yield over large areas. Especially, in developing countries, this technique can be very helpful in establishing large data sets on sediment delivery as often no resources are available for expensive monitoring programmes. However, when such studies are undertaken, one has to take into account the efficiency of the pond in trapping sediments which is known as the *trap efficiency*. This trap efficiency is dependent on the characteristics of the inflowing sediment and the retention time of the water in the pond, which in turn are controlled by pond geometry and runoff characteristics. Trap efficiency (*TE*) is the portion of the incoming sediment that is deposited, or trapped, in a reservoir or pond.

$$TE = \frac{S_{inflow} - S_{outflow}}{S_{inflow}} = \frac{S_{settled}}{S_{inflow}} \quad (22.4)$$

where, S_{inflow} = the sediment mass entering a reservoir (= the sediment yield or delivery); $S_{outflow}$ = the sediment mass leaving the reservoir with the out flowing water; $S_{settled}$ = the sediment mass deposited within the reservoir. To obtain data on *TE* for selected reservoirs or ponds, one can use the following methods:

1. Reservoir survey with suspended-load measurements downstream,

2. Reservoir survey with suspended-load measurements upstream, and
3. Suspended-load measurements up and downstream.

22.4.2 Sediment Delivery Ratio

It is the ratio between the yield of sediment at the measuring site and the gross erosion in the catchment.

$$S_{DR} = \frac{S_D}{S_G} \quad (22.5)$$

where, S_{DR} = the sediment delivery ratio; S_D = the sediment amount delivered to downstream at a particular gauging site; and S_G = the total sediment generated over the land surface catchment to the gauging point.

22.5 Reservoir Sedimentation Control

In order to increase the life of reservoirs, it is very essential to control the problem of sedimentation *i.e.* deposition of sediment in the reservoir. Various control measures which are adopted to control the reservoir sedimentation can be classified into the following two types:

1. Pre Constructive Measures
2. Post Constructive Measures

1. Pre Constructive Measure: It refers to those measures which are adopted before and during the execution work of the reservoir construction. These measures can be enumerated as follows:

- a) **Selection of Dam Site:** The amount of sediment reaching the reservoir from a catchment area depends upon the soil erosion caused by water. If the catchment area is less susceptible to erosion, then less silts are charged into the stream flow. As a result reservoir silting will be less.
- b) **Design Capacity of Reservoir:** The design capacity of reservoir plays a significant role in the reservoir sedimentation. When the storage capacity is less than the volume of stream flow coming into the reservoir, then a large volume of water will be out from the reservoir quickly. This result in deposition of much less sediment in the reservoir compared to when the reservoir capacity-inflow ratio is high.
- c) **Construction of Check Dam:** Check dams play a key role in controlling the inflow of sediment into the reservoir. The check dams are constructed across the stream/river to trap the major portion of sediment load. These dams trap large amount of coarser sediments.
- d) **Installation of Vegetative Screen:** Vegetative screen is a vegetative cover through which flood water passes, before entering into the reservoir. The control of sediment entry into a reservoir by use of vegetative screen is based on the principle that vegetations trap large amount of sediments by reducing the flow velocity and filtering the soil particles from the flood water. It is one of the best and cheapest methods of silt control.

e) Construction of Sluice Gate under the Dam: There must a provision for installation of sluice gate at the base of the reservoir dam to remove the silted water from the reservoir. The sediment concentration is more at the bottom of the reservoir. Therefore, sluice gates (silt excluder) should be located at the lower portion of the dam. This method is not much suitable as the flow of water tends to develop a channel behind the sluice from where water flow takes place and as a result most of the silts do not get flushed as they remain undisturbed. It is very essential that the release of sediment from the reservoir through the sluice gate must be simultaneously supported by mechanical loosening and scouring of the neighbouring sediments to increase its effectiveness. However, since this method has structural problem it is not widely used.

f) Reservoir Operation: The sediment delivery rate increases with the rate of volume of discharge, which depends on the demand of water of the command area. The amount of sediment trapped by the reservoir for a given drainage area, increases with the increase in its capacity. The sedimentation rate decreases with more rigorous use of the reservoir. The ratio of the reservoir capacity and the size of the drainage basin is one of the most important factors which govern the annual rate of sediment accumulation in the reservoir.

g) Erosion Control: The erosion is a main source of sediment yield. To control sedimentation problem of reservoirs, the control of erosion is most essential. The erosion control measures include all those measures which are effective in preventing or delaying the movement of sediment laden flow from the origin.

2. Post Constructive Measure: Post constructive measures are undertaken during the operation of the reservoir. It includes the following methods.

a) Removal of Flood Water: It is well known that the sediment content is more in the stream water during initial stage of the flood. Therefore, this phase of flood water is not advised to be collected into the reservoir.

b) Stirring of Sediment: It is generally performed by using a mechanical stirrer. Due to this, the deposited sediment is scoured and disturbed in the water, which is flushed outside through the sluice gates.

c) Removal of Silt Deposits: The deposited sediments in the reservoir are also removed by excavation, dredging and sluicing with hydraulic or mechanical agitators. Dredging method is the most expensive method among all and is not economically feasible for all water storage works.



Module 6: Topographic Survey and Contour Maps

Lesson 23 Land Survey and Contour Maps

The purpose of topographic survey is to get the necessary data to produce a topographic map of the earth's surface. This map will include contour lines, location of natural features, such as streams, gullies, and ditches and man-made features like bridges, culverts, roads, fences, etc. which are essential for detailed planning. The best practical method of presenting topography is by means of land surveys and contour maps.

23.1 Survey of Land

Land surveying is the science and art of making all essential measurements to determine the relative position of points or physical and cultural details above, on, or beneath the surface of the earth and to depict them in a usable form, or to establish the position of points or details. These points are usually on the surface of the earth and they are often used to establish land maps and boundaries for ownership or governmental purposes. Furthermore, it is the detailed study or inspection by gathering information through observations, measurements in the field, questionnaires, or research of legal instruments and data analysis for the purpose of planning, designing, and establishing property boundaries. It involves the re-establishment of cadastral surveys and land boundaries based on documents of record and historical evidence, as well as certifying surveys (as required by statute or local ordinance) of subdivision plans/maps, registered land surveys, judicial surveys and space delineation.

Land surveying can include associated services such as mapping, related data accumulation, construction layout surveys, precision measurements of length, angle, elevation, area, volume, as well as horizontal and vertical control surveys. It also includes the analysis and utilization of land survey data. Surveying has been an essential element in the development of the human environment since the beginning of recorded history (about 5,000 years ago). It is required in the planning and execution of nearly every form of construction. Its most familiar modern uses are in the fields of transport, building and construction, communications, mapping and the definition of legal boundaries for land ownership.

The earliest surveys were performed only for the purpose of recording the boundaries of plots of land. Due to advancements in technology, the science of surveying has also attained its due importance. In the absence of accurate maps, it is impossible to lay out the alignment of roads, railways, canals, tunnels, transmission, power lines, and microwave or television relaying towers. Detailed maps of the sites of engineering projects are necessary for the precise installation of sophisticated plants and machineries. Surveying is the first step for the execution of any such project.

23.2 Types of Maps and Mapping Units

The following types of maps are used in land surveying.

- **Plan:** A plan is a graphical representation of the features on the earth surface or below the earth surface as projected on a horizontal plane. This may not necessarily show its graphical position on the globe. On a plan, horizontal distances and directions are generally shown.
- **Map:** The representation of the earth surface on a small scale is called a map. The map must show its geographical position on the globe with the help of latitude and longitude. On a map the topography of the terrain, is depicted generally by contours, hachures and spot levels.
- **Topographical Map:** The maps which are on sufficiently large scale to enable the individual features shown on the map to be identified on the ground by their shapes and positions, are called *topographical maps*.
- **Geographical Maps:** The maps which are on such a small scale that the features shown on the map are suitably generalised and give a picture of the country as a whole and not a strict representation of its individual features, are called *Geographical maps*.

Two kinds of measurements are used in plane surveying;

- Linear Measurement, i.e. Horizontal or Vertical Distance
- Angular Measurement, i.e. Horizontal or Vertical Angles.

i) **Linear Measures:** According to the standards of Weight and Measure Act (India) 1956, the metric system has been introduced in India. Before 1956, F.P.S (Foot, pound, second) system was used for the measurements. For measurements of distances, metre and centimetre have been recommended as standard units.

Basic units of length in metric system:	10 millimetres = 1 centimetre 10 centimetres = 1 decimetre 10 decimetre = 1 metre 10 metres = 1 decametre 10 decametres = 1 hectametre 10 hectametres = 1 kilometres 1.852 kilometres = 1 nautical mile
Basic units of area in metric system	100 sq. metres = 1 are 10 ares = 1 deka-are

	10 deca ares = 1 hecta-are
Basic units of volume in metric system	1000 cub. millimetres = 1 cub. centimetre 1000 cub. centimetres = 1 cub. decimetre 1000 cub. decimetres = 1 cub. metre
Basic units of length in FPS system	12 inches = 1 foot 3 feet = 1 yard 5.5 yards = 1 rod, pole, or 1 sq. perch 4 poles = 1 chain (66 feet) 10 chains = 1 furlong 8 furlong = 1 mile 6 feet = 1 fathom 120 fathoms = 1 cable length 6080 feet = 1 nautical mile
Basic units of volume in FPS system	1728 cu. inches = 1 cu. Foot 27 cu. Feet = 1 cu. Yard

Conversion Factor for Lengths

Metres	Yards	Feet	Inches
1	1.0936	3.2808	39.37
0.9144	1	3	36
0.3048	0.3333	1	12
0.0254	0.0278	0.0833	1

Conversion Factor for Areas

Sq. metres	Sq. yards	Sq. feet	Sq. inches
1	1.196	10.7639	1550
0.8361	1	9	1296
0.0929	0.1111	1	144
0.00065	0.00077	0.0069	1

Conversion Factor for Areas

Ares	Acres	Sq. metres	Sq. yards
1	0.0247	100	119.6
40.496	1	4046.9	4840
0.01	0.000247	1	1.196
0.0084	0.00021	0.8361	1

Conversion Factor for Volumes

Cub. Metres	Cub. yards	Gallons (Imps)
1	1.308	219.969
0.7645	1	168.178
0.00455	0.00595	1

ii) **Angular Measures:** Angles may be defined as the difference in the direction of two intersecting lines; it is the inclination of two straight lines. The unit of a plane angle is 'radian'. Angle is defined as the measure between two radii of a circle which contain an arc equal to the radius of the circle. The popular system of angular measurements, are:

- **Sexagesimal System of Angular Measurements:**

In this system the circumference of a circle, is divided into 360 equal parts, each part is known as one degree. $1/60^{\text{th}}$ part of a degree is called a *minute* and $1/60^{\text{th}}$ part of a minute, is called a second. i.e.

1 circumference = 360 degree of arc

$1^{\circ} = 60$ minutes of arc

1 minute = 60 seconds of arc

- **Centesimal System of Angular Measurements:**

In this system circumference of a circle is divided into 400 equal parts, each part is known as grad. One hundredth part of a grad is known as *centigrad* and one hundredth part of a centigrad is known *centi-centigrad*. i.e.

1 circumference = 400 grads

1 grad = 100 centigrads

1 centigrad = 100 centi-centigrads

From the ancient times, sexagesimal system is being widely used in different countries of the world. Most complete mathematical tables are available in this system and most surveying instruments i.e. theodolites, sextants etc. are graduated according to this system. Due to increased facility in computation and interpolation, the centesimal system for angular measurements is gaining popularity in the western countries these days.

Conversion Factors from One System to Other

Degrees	Grads	Minutes	Centigrads	Seconds	Centi-centigrads
1	1.1111	60	111.11	3600	11111
0.9	1	54	100	3240	10000
0.0167	0.01852	1	1.8518	60	185.18
0.0090	0.0100	0.5405	1	32.4	100
0.00027	0.0003	0.0167	0.0309	1	3.0864
0.00009	0.0001	0.0054	0.0100	0.324	1

23.3 Methods of Land Survey

The surveying may be primarily divided into two divisions.

- Surveying
- Geodetic Surveying

23.3.1 Plane Surveying: The survey in which the earth surface is assumed as a plane and the curvature of the earth is ignored is known as plane survey. In plane surveying, every elevation measurement has a small amount of error; however, plane surveying is easier to complete and provides sufficient accuracy for smaller areas. As plane survey extends only up to small areas, the lines connecting any two points on the surface of the earth, are treated as straight lines and the angles between these lines are taken as plane angles. Surveys covering an area up to 260 km² may be treated as plane surveys because the difference in length between the arc and its subtended chord on the earth surface for a distance of 18.2 km is only 0.1 m. Plane surveying is used for the layout of highway, railways, projects, canals, fixing boundaries, pillars, construction of bridges, factories etc. For proper, economical and accurate planning of projects, plane survey is needed and its practical significance cannot be overestimated.

23.3.2 Geodetic Surveying: The art of surveying the earth surface considering its shape and size (curvature) is called *geodetic surveying*. Geodetic surveying is suitable for finding out the area of any region on the earth surface, the length and directions of the border lines, contour lines and location of basic points. It is assumed that the shape of earth is spheroid. The convention held by the International Geodetic and Geophysical Union in 1924 assumed 41,852,960 ft as the earth's diameter at the equator and at the poles the diameter is 41,711,940 ft. Thus, measurement of distances is taken along curved surfaces and not along straight lines. The latitudes and longitudes are determined considering the spheroidal shape of the earth. The points which are used to find out the shape, size and coordinates of the earth surface is called *geodetic datum*. In India, geodetic surveys are conducted by the department of the Survey of India under the direction of the Surveyor General of India.

Different kinds of surveys are taken up depending on the nature of the field and purpose of the survey. These include topographic surveys, cadastral surveys, city surveys, hydrographic surveys, astronomical surveys, engineering surveys, military or defense surveys, mine surveys, geographical surveys, archaeological surveys etc. Based on the instruments used surveys may also be classified as chain surveying, compass surveying, plane table surveying, theodolite surveying, tachometric surveying, triangulation surveying, aerial surveying and photogrammetric surveying.

Basic surveying measurements include the following eight aspects

1. Determining Horizontal Position: The horizontal position of points is usually determined using traversing, triangulation, trilateration or grid referencing methods.

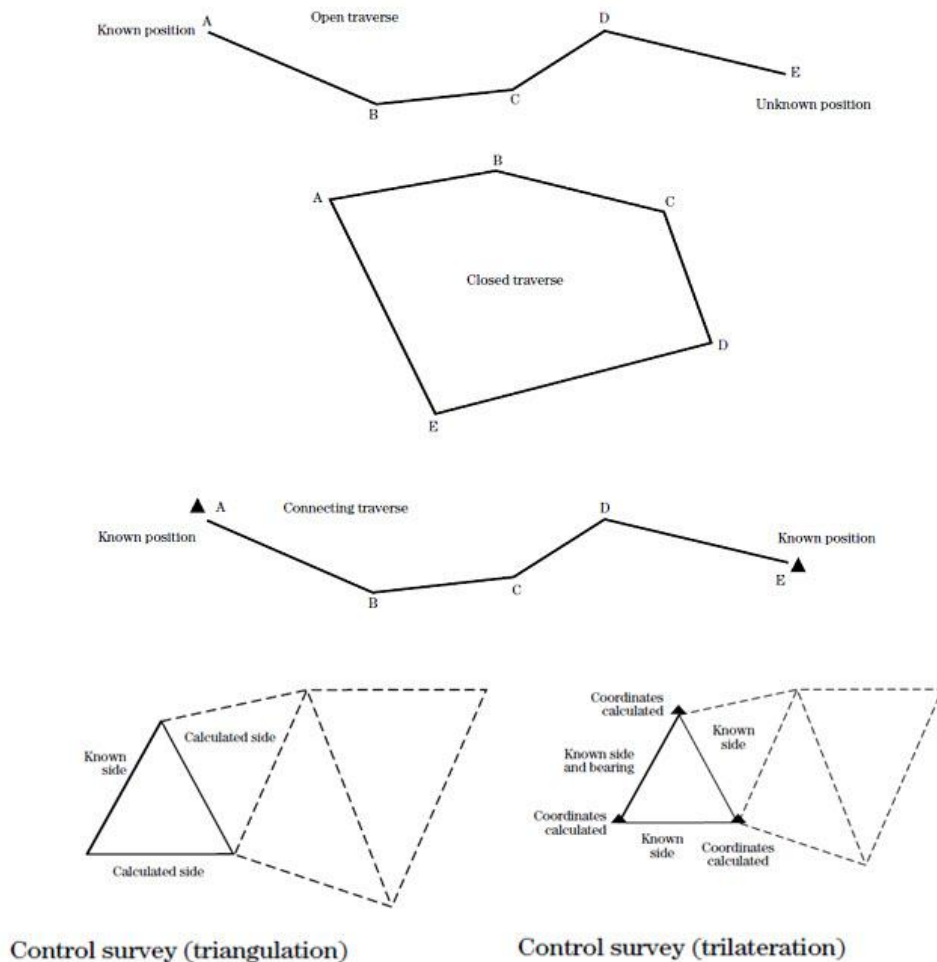

Fig. 23.1. Methods for Measuring Horizontal Position.

2. **Determining Horizontal Distance:** Measurement of horizontal distances can be accomplished by a number of methods including pacing, taping, stadia, and electronic distance measuring devices. The choice of measurement device usually is determined by the accuracy required.
3. **Determining Horizontal Angles:** The direction of any line on a course is determined by the reference angle in the horizontal plane to the previous line on the course. Three types of reference angles; interior angles, exterior angles, deflection angles.
4. **Determining Direction:** Course direction is expressed by the bearing of a particular leg of the course. When there is a change in course direction, a new bearing can be calculated given the bearing of the first course direction and the angle of the change in course direction.
5. **Determining Vertical Position:** The vertical position of points is determined from a series of level readings. Level surveys are referenced to a datum. Mean sea level usually is used as a standard datum; however, an assumed datum may be used for minor surveys. Vertical distances above and below a datum are called elevations. Vertical distance is measured as the elevation difference between any two points with reference to a datum.
6. **Determining Vertical Distance:** Vertical distance is one side of a right triangle and is calculated by the relationship –

$$\% \text{ Slope} = \frac{\text{Rise}}{\text{Run}} = \frac{\text{Vertical distance}}{\text{Horizontal distance}}$$

7. Determining Vertical Angles: Vertical angles can be expressed either as a true vertical angle or as a zenith angle. A true vertical angle is an angle measured from the horizontal either upward or downward. Vertical angles measured upwards from the horizontal are positive angles and those measured downward are negative angles. Zenith angles are measured downward from a vertical plumb line above the point. The zenith angle is measured from 0 degrees directly above and is equal to 90 degrees minus the vertical angle.

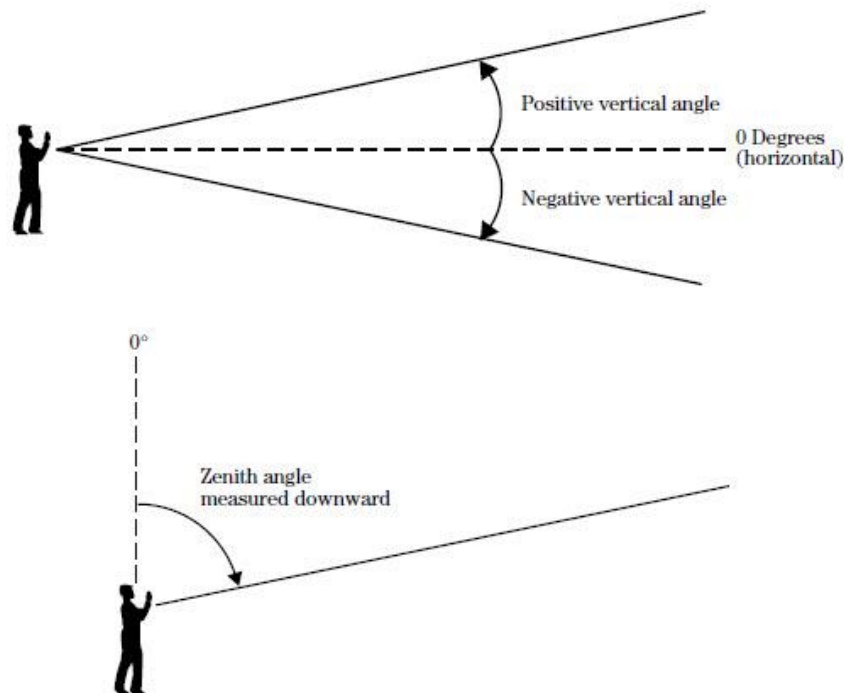

Fig. 23.2. Methods for Measuring Vertical Angles.

8. Determining Vertical Coordinate Position: Vertical coordinate position is also known as the elevation of the point and is determined by adding or subtracting the vertical difference between a known point and the position being calculated to the elevation of the known point.

23.4 Contour Maps Preparation

An imaginary line on the ground, joining the points of equal elevation above the assumed datum is called a contour line. It is a plan projection of the plane passing through the points of equal elevation on the surface of the earth. Concept of a contour can be made clear by surveying the boundary of still water in a pond. If the level of the water surface is 100 m, then the periphery of water represents a contour line of 100 m. If the water level is reduced by 5 metres, the new periphery of water will then represent a contour of 95 m. The following characteristics of contours are kept in view while preparing or reading a contour map.

- Two contours of equal elevation do not cross each other except in the case of an over-hanging cliff.

- Contours of different elevations do not unite to form one contour except in the case of a vertical cliff.
- Contours lines located close to each other indicate a steep slope and those located far apart represent a gentle slope.
- Contours equally spaced depict a uniform slope. Parallel, equidistant and straight contours lines represent an inclined plane surface.
- Contours at any point are perpendicular to the line of the steepest slope at the point.
- A contour line must close itself but need to be necessarily within the limits of the map itself.
- Ring contours with higher values inside depict a hill whereas a set of ring contours with lower values inside represent a pond or a depression without an outlet.
- When contours cross a ridge or V-shaped valley, they form sharp V-shapes across them. Contours represent a ridge line, if the concavity of higher value contours lies towards the next lower value contour and a valley if the concavity of the lower value contours lies towards the higher value contour.
- The same contour must appear on both the sides of a ridge or a valley.
- Contours do not have sharp turnings.

Field work for locating contours may be in various ways according to the instruments used. The various methods of locating contours may be divided into two main classes:

- Direct Method
- Indirect Method

i) Direct Method: In the direct method, the contour to be plotted is actually traced on the ground. Points which happen to fall on a desired contour are only surveyed, plotted and finally joined to obtain the particular contour. This method is slow and tedious and thus used for large scale maps, small contour interval and high degree of precision. A temporary benchmark is established near the area to be surveyed with reference to a permanent bench mark. The level is then set up in such a position so that the maximum number of points can be commanded from the instrument station. The height of instrument is determined by taking a back sight on the benchmark and adding it to the reference level of bench mark. The staff reading required to fix points on the various contours is determined by subtracting the Reduced Level (R.L.) of each of the contours from the height of instrument.

ii) Indirect Method: In practice, generally indirect method is used. In this method sufficient numbers of points are given spot levels. The location of such points can be conveniently plotted on a plane table section as these generally form the corners of the well, shaped geometrical figures i.e. squares, rectangles, triangles, etc. It is seldom possible to have exact spot level of any point on exact value of the contour. The spot level of the important features which represent hill tops, ridge lines, bed of streams and lowest points of the depression are also taken, to depict their correct features while drawing contour lines. The contours in between spot levels are interpolated and drawn. This method of contouring is sometimes known as contouring by spot levels. Indirect method of contouring is commonly employed

in small scale surveys of extensive areas. This method is cheaper, quicker and less tedious as compared to the direct method of contouring.

23.5 Uses of Contour Maps in SWCE

Keeping in view, the characteristics of contours enumerated above, different natural features may be shown by contours. Followings are some of the important uses:

- To study the general character of the tract of the country without visiting the ground. With the knowledge of the characteristic of the contours, it is easier to visualise whether the country is flat, undulating or mountainous.
- To decide the most economical and suitable sites of re-engineering for engineering works such as canals, sewers, reservoirs, roads, railways etc.
- To determine the catchment area of the drainage basin and hence the capacity of the proposed reservoir.
- To compute the earth work required for filling or cutting along the linear alignment of projects such as canals, roads, etc.
- Site selection and dimensioning of soil and water conservation measures like contour bunds, contour trenches etc.



AGRIMOON.COM

All About Agriculture...

Lesson 24 Leveling and Grading of Land

Land leveling is the process of modifying the surface relief by smoothing it. It is the process of flattening or modifying existing (natural) slopes or undulations and thereby creating a level surface. Normally land leveling requires excavation and movement of earth from higher elevations to lower elevations. Land grading is modifying the slope of land to a planned grade (slope) and specifications for different purposes (e.g. irrigation planning). The operations are usually accomplished using special equipments to eliminate the minor irregularities but not to change the general topography of the land surface.

24.1 Purpose of Leveling and Grading of Land

The art of determining relative altitudes of points on the surface of the earth or beneath the surface of the earth is called levelling. For the execution of engineering projects, such as railways, highways, canals, dams, water supply, and sanitary schemes, it is necessary to determine the elevation of different points along the alignments of the proposed elevations. Levelling is employed to provide an accurate network of heights, covering the entire area of a project. Levelling is of prime importance to the engineers, both in acquiring necessary data for the design of the project and also during execution. Land grading involves reshaping the ground surface to planned grades as determined by an engineering survey, evaluation, and layout. Land grading provides more suitable topography for buildings, facilities and other land uses and helps to control surface runoff, soil erosion and sedimentation from the ungraded land during and after construction. Land grading is applicable to sites with uneven or steep topography or easily erodible soils, because it stabilizes slopes and decreases runoff velocity. Grading activities should maintain existing drainage patterns as much as possible.

24.2 Methods of Leveling and Grading

Levelling may be categorized into two types.

- Simple levelling
- Differential leveling

24.2.1 Simple Leveling

The operation of levelling for determining the difference in elevation, if not too great, between two points visible from a single position of the level is known as simple levelling. Suppose A and C are the two points whose difference in elevation, is required to be measured with a levelling instrument set up at B. To eliminate the effect of the earth's curvature and instrumental errors, it is advisable that the level is set up at equal distance from points A and C but not necessarily on the line joining them. (Fig.24.1)

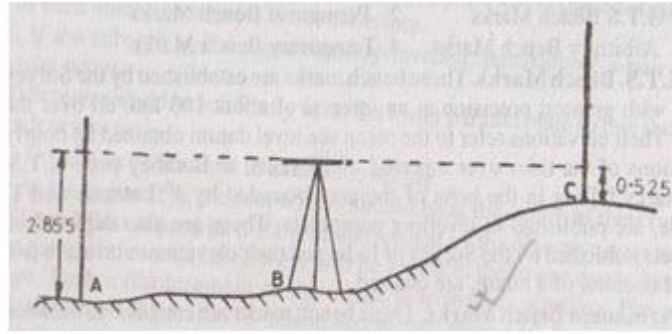

Fig. 24.1. Simple Leveling. (Source: Venkatramaiah, 1996)

Following steps should be used

- The telescope of the instrument should be levelled using standard procedure.
- The telescope is focused on the levelling staff held vertically on A.
- Readings of the central horizontal hair of the diaphragm where it appears to intersect the staff is taken ensuring that the bubble of the level is central.
- The staff is shifted to C.
- The telescope is directed towards C and again focussed.
- Initial levelling should be such that even after rotating the telescope, the telescope remains horizontal.
- Reading of the central horizontal line is then taken.

Illustration I

Let the respective readings on staff A and staff C be 2.855 and 0.525m respectively. The difference of level between A and C: $2.855 - 0.525 = 2.330$ m

If Reduced Level (R.L.) of A = 500.000 m, R.L of B may be calculated as:

R.L of point A = 500.000m

R.L. of the line of sight = $500.000 + 2.855 = 502.855$ m

R.L. of the point C = $502.855 - 0.525 = 502.330$ m

Illustration II

If one of the points is on the floor and the other is on the ceilings such as in tunnels or buildings, the staff at the elevated point, may be held vertically inverted (Fig.24.2).

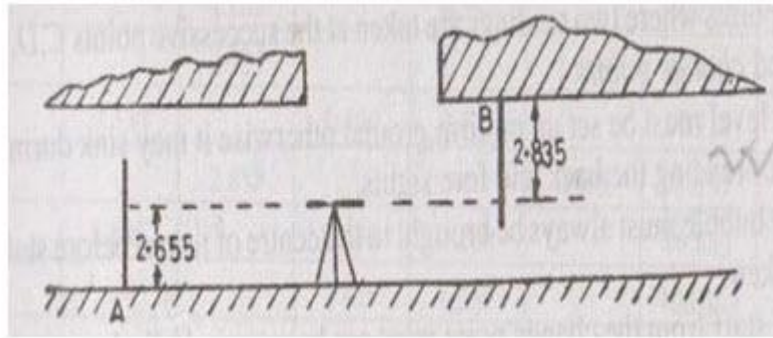

Fig. 24.2. Simple Leveling with Inverted Staff. (Source: Venkatramaiah, 1996)

If the elevation of A = 200.000 m

Back sight reading on A = 2.655 m

Fore sight reading on B = 2.835 m

R.L. of the line of sight = 200.000 + 2.655 = 202.655 m

So, R.L. of the point B = 202.655 + 2.835 = 205.490 m

24.2.2 Differential Leveling

The method of levelling for determining the difference in elevation between two points either too far apart or obstructed by an intervening ground, is known as differential levelling. In this method, the level is set up at a number of points and the difference in elevation of successive points, is determined as in the case of a levelling. Let us suppose that A and B are two points which are far apart and the difference in their elevation, is to be determined by differential levelling. (Fig. 24.3)

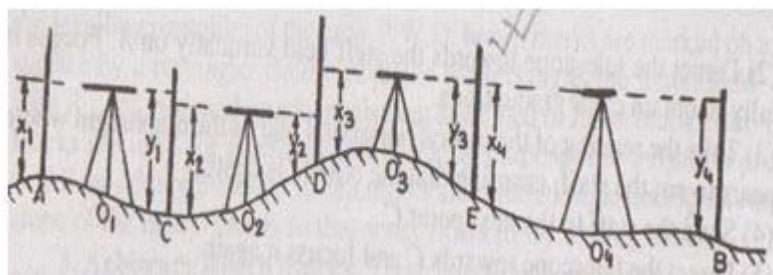

Fig. 24.3. Differential Leveling. (Source: Venkatramaiah, 1996)

Procedure: Following steps are involved.

- The level is set up at O_1 ensuring that the line of sight intersects the staff held at A. It is levelled correctly.
- With the bubble at central position, take the back sight staff reading on the staff held vertically at A.
- Select a point C equidistant from the instrument position O_1 and take the fore sight staff reading on the staff reading on the staff held vertically at C.
- Shift the instrument to O_2 , set up and level it correctly.

- With the bubble central, take back sight staff reading on the staff held vertically at C again.
- Select a point D equidistant from the instrument position O_2 and take the fore sight staff reading on the staff held vertically at D .
- Repeat the process until the fore staff reading is taken on the staff held on the point B .

Notes: The following points may be noted.

- The point where two readings are taken at the successive points C, D, E etc. are called change points.
- The level must be set up on firm ground otherwise it may sink during the interval of reading the back and fore sights.
- The bubble must always be brought to the centre of its run by leveling the instrument before the staff reading is taken.
- The staff from the change point must not be removed till a back sight is taken from the next instrument station by turning round the staff to face the telescope.

Illustration I

Let $x_1, x_2, x_3, x_4, \dots, x_n$ be back sights and $y_1, y_2, y_3, y_4, \dots, y_n$ be the fore sights taken on the staff held vertically at A, C, D, \dots etc.

Difference of level between A and $C = x_1 - y_1$

Difference of level between C and $D = x_2 - y_2$

Difference of level between N and $E = x_3 - y_3$ and so on.

The difference of level of point A and B is equal to the difference of algebraic sum of back sights and algebraic sum of fore sights, i.e. $\sum B.S - \sum F.S$. If the difference in level is positive, the closing point B is higher than the starting point A , whereas; if it is negative, the point B is lower than the point A .

Therefore, R.L. of the point $B = \text{R.L. of point } A \pm (\sum B.S - \sum F.S)$

24.3 Design of Land Grades

Before grading activities begin, a construction site operator must make decisions regarding the steepness of cut-and-fill slopes and how the slopes will be protected from runoff, stabilized and maintained. Preparation of a grading plan that establishes which areas of the site will be graded, how drainage patterns will be directed and how runoff velocities will affect receiving waters is essential. Also in the grading plan, information about when earthwork will start and stop should be included along with the establishment of the degree and length of finished slopes and where and how excess material will be disposed off (or from where borrow materials will be obtained if needed). Minimization of exposed soils at any given time during construction and incorporation of any berms, diversions, and other storm water practices that require excavation and filling in the plan should be borne in mind. Land grading is therefore a key consideration for construction sequencing.

Care should be taken if blasting agents or explosives are used. These products may contain perchlorates, which are water soluble chemicals. If explosives containing perchlorate are used, then good housekeeping practices should be employed to ensure that any debris is properly disposed. Maintaining undisturbed temporary or permanent buffer zones in the grading operation provides a low-cost sediment control measure that will help reduce runoff and offsite sedimentation.

24.4 Estimation of Earthwork in Leveling and Grading

Earthwork operations are one of the most important construction aspects in road and airfield construction. Earthwork requires the greatest amount of engineering effort from the standpoint of personnel and equipment. Therefore, the planning, scheduling and supervision of earthwork operations are important in obtaining an efficiently operated construction project. Earthwork computations involve the calculation of earthwork volumes, the determination of final grades, the balancing of cuts and fills, and the planning of the most economical haul of material. The exactness with which earthwork computations are made depends upon the extent and accuracy of field measurements, which in turn are controlled by the time available and the type of construction involved. To plan a schedule, the quantity of earthwork and the soil and haul conditions must be known so that the most efficient type and quantity of earthmoving equipment can be chosen and the appropriate time may be allotted. When time is critical, the earthwork quantities are estimated either very roughly or not at all. When time is not critical, higher construction standards are possible and earthwork quantities are estimated and controlled by more precise methods.

The volume of a rectangular object may be determined by multiplying the area of one end by the length of the object. This relationship can be applied for the determination of earthwork by considering road cross sections at the stations along the road as the end areas and the horizontal distance between cross sections as the lengths. The end areas of the cross sections must be computed before volumes can be calculated.

24.5 Methods of End-Area Determination

When the centre line of the construction has been located, measurements are taken in the field from which the required quantities of cut or fill can be computed. A cross sectional view of the land is plotted from these measurements. The cross sections are taken on vertical planes at right angles to the centre line. Where the ground surface is regular, cross sections are taken at every full station (100 feet), where the ground is irregular; they must be taken at intermediate points as determined by the surveyor. A typical cross section is shown in Fig. 24.4.

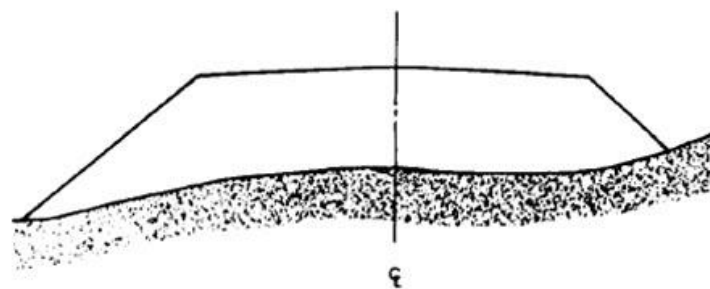

Fig. 24.4. Typical Fill Cross Section. (Source: Venkatramaiah, 1996)

The following steps may be followed for determination of volume of earthwork.

1. Plot ground elevations from the surveyor's notes.
2. Make a sectional template of the sub-grade that shows the finished sub-grade and slopes plotted to the same scale as the cross sections.
3. Superimpose the template on the cross section and adjust it to the correct centre line elevation.
4. Trace the template and extend the side slopes to intersect the original ground.
5. If the section involves both cut and fill, draw only the appropriate lines of each template.
6. When the sections are completed, begin the end-area measurements, and then determine the volume.

Of the several satisfactory methods of measuring the end areas, only the trapezoidal and planimeter methods are discussed here. The method chosen will depend upon the time available, the accuracy desired, the aids at hand, and the engineer's preference.

24.5.1 Trapezoidal Method

The trapezoidal method is widely used to determine end areas. The computations are tedious, but the results are accurate. In using the trapezoidal method, the area of any cross section is obtained by dividing the cross section into triangles and trapezoids, computing the area of each part separately and taking the total area of the verticals to the ground line (Fig. 24.5) in order to divide the cross section into two triangles and two trapezoids. Assumption is made that the ground is perfectly straight between these selected points on the ground line. While this is not usually correct, the assumption is within the accuracy normally required.

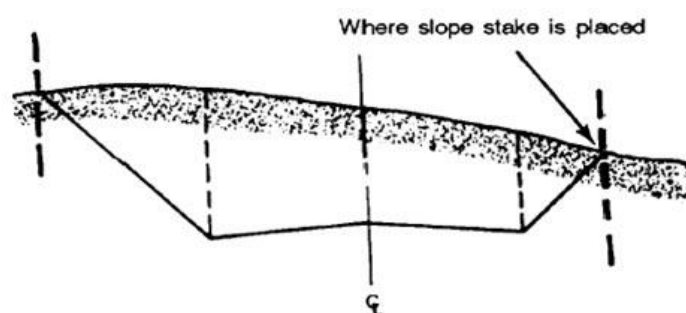

Fig. 24.5. Cross Section in Cut with Verticals Drawn at Critical Points.

Before the area of the cross section can be computed, the basic formulae for the computation of the areas of triangles and trapezoids must be understood.

Computation of Areas: The first step in computing areas by the trapezoidal method is to break the cross-sectional area into triangles and trapezoids by drawing verticals, as shown in Fig. 24.5. Then determine the area of these small figures by the appropriate formula. To determine the appropriate dimensions, the notes taken by the surveyors must be known. The cross-section notes taken in the field are in fractional form. The figure below the line indicates the horizontal distance from the centre line to that point on the ground. The figure

above the line indicates the ground elevation of that point. Points on the grade line of the proposed road are written in a similar manner and are obtained by computations from the final grade line to be established as shown in Fig.24.8. Thus, the note 32.0/21 indicates a point that is at elevation 32.0 and 21 feet from the centreline of the road. If the cross section is divided into triangles and trapezoid by erecting verticals, obtain notes for the centre line, shoulders, and end of slopes to determine the area.

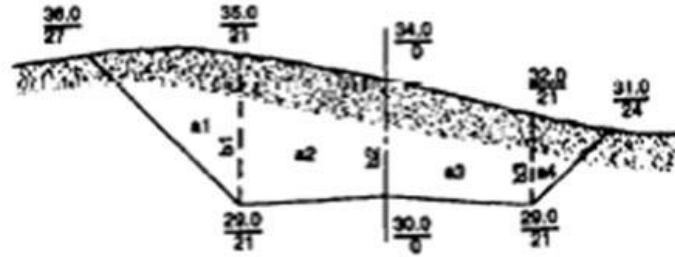

Fig. 24.6. Cross Section Cut Showing Distances and Elevations

To determine areas of the triangles and trapezoids formed, consider the bases of these figures to be vertical and the altitudes to be horizontal. All vertical bases are found by subtracting elevations, and all horizontal altitudes are found by subtracting horizontal distances from the closest vertical in the direction of the centreline.

Examples 24.1: Referring to figure 24.6, the area is found out as follows:

Substituting the values in the formula, the area of a triangle is obtained.

$$a_1 = \frac{1}{2}bh = \frac{1}{2}[(35.0 - 29.0)(27 - 21)]$$

$$= \frac{1}{2}(6.0)(6) = 18 \text{ square feet}$$

substituting in the formula for the trapezoid:

$$a_2 = \frac{1}{2}(b_1 + b_2)h$$

$$= \frac{[(35.0 - 29.0) + (34.0 - 30.0)](21 - 0)}{2}$$

$$= \frac{1}{2}(6.0 + 4.0)(21) = 105.0 \text{ square feet}$$

Similarly, all other areas in the figure can be found out with the same procedure.

24.5.2 Planimeter Method

A polar planimeter is an instrument used to measure the area of a plotted figure by tracing its perimeter. The planimeter, shown in Fig. 24.7 touches the paper at three points: the anchor point, P; the tracing point, T; and the roller, R. The adjustable arm, A, is graduated to permit adjustment to the scale of the plot. This adjustment provides a direct ratio between

the area traced by the tracing point and the revolutions of the roller. As the tracing point is moved over the paper, the drum, D and the disk, F revolve. The disk records the revolutions of the roller in units of tenths; the drum, in hundredths; and the vernier, V in thousandths.

The accuracy of the planimeter as a measuring device should be checked to avoid errors due to temperature changes and other non-compensating factors. A simple method of testing its consistency is to trace an area of 1 square inch with the arm set for a 1:1 ratio. The disk, drum, and vernier combined should read 1.000 for this area. Before measuring a specific area, the scale of the plot should be determined and the adjustable arm of the planimeter should be set according to the chart in the planimeter case. The setting should be checked carefully by tracing a known area, such as five large squares on the cross section paper and verifying the reading on the disk, drum and vernier. If the reading is inconsistent with the known area, the arm settings should be readjusted until a satisfactory reading is obtained. To measure an area, the anchor point of the adjusted planimeter should be set at a convenient position outside the plotted area. The tracing point is placed on a selected point on the perimeter of the cross section. An initial reading is taken from the disk, drum, and vernier. Tracing is continued on the perimeter clockwise, keeping the tracing point carefully on the lines being followed. When the tracing point closes on the initial point, a reading is taken again from the disk, drum, and vernier. The difference between the initial reading and the final reading gives a value proportional to the area being measured.

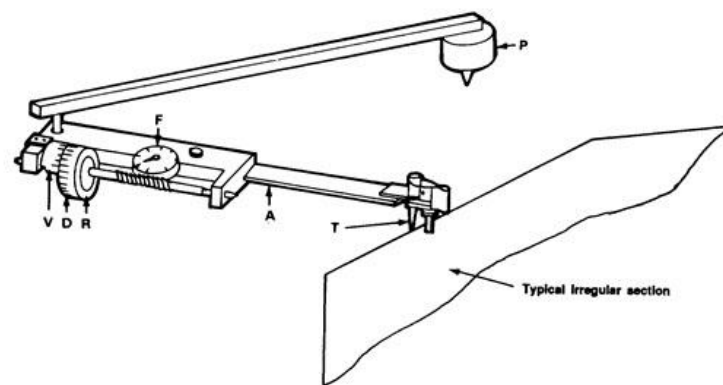

Fig. 24.7. Polar Planimeter in Use. (Source: Venkatramaiah, 1996)

Two independent measurements should be made to ensure accurate results. The first is performed as discussed above. The second measurement is made with the anchor point again placed outside the area being measured but on the opposite side of the area from its position in the first measurement. This procedure gives two compensating readings the mean of which is more accurate than either. To measure plotted areas larger than the capacity of the planimeter, the area is divided into sections and each section is measured separately as outlined above.

24.6 Construction and Maintenance

Construction sequencing is a specified work schedule that coordinates the timing of land-disturbing activities and the installation of erosion and sediment control measures. The goal of a construction sequence schedule is to reduce on-site erosion and off-site sedimentation by performing land-disturbing activities and installing erosion and sediment control practices in accordance with a planned schedule.

Construction site phasing involves disturbing only part of a site at a time to prevent erosion from dormant parts. Grading activities and construction are completed and soils are

effectively stabilized on one part of the site before grading and construction commence at another part. A key consideration of grading activities should be the coordination of cuts and fills to minimize the movement and storage of soils on, off and around the site. This differs from the more traditional practice of construction site sequencing, in which site-disturbing activities are performed initially for all or a large section of the site, leaving portions of the disturbed site vulnerable to erosion. To be effective, construction site phasing needs to be incorporated into the overall site plan early. Elements to be considered when phasing construction activities include the followings:

- Managing runoff separately in each phase,
- Determining whether water and sewer connections and extensions can be accommodated,
- Determining the fate of already completed downhill phases and
- Providing separate construction and residential accesses to prevent conflicts between residents living in the completed stages of the site and in the area where construction equipment will work later.

Maintance Considerations: All the graded areas and supporting erosion and sediment control practices should be checked periodically, especially after heavy rain falls. All the sediments from diversions or other storm water conveyances should be promptly removed and if washouts or breaks occur, they should be repaired immediately. To prevent small-scale eroded areas from developing into gullies, they should be maintained regularly.



AGRIMOON.COM

All About Agriculture...

Module 7: Land Use Capability Classification

Lesson 25 Land Use and Capability Classification

The land in any place is used for several purposes such as crop and livestock production, forestry, housing, recreation, residential areas, markets, roads, railways etc. The most desired way of using a particular land is possible when one can understand the type of the soil in the land capability classification which gives complete information regarding various parameters based on which classification is done.

25.1 Soil Use and Land Capability Classification

Land capability classification is a system of grouping soils primarily on the basis of their capability to produce common cultivated crops and pasture plants without deterioration over a long period of time. Land capability classification is subdivided into capability class and capability subclass. Important factors on which the classification is based are:

1. The soils are well managed and cropped under a mechanized system.
2. Land requiring improvements including clearing that can be possible by the farmer with his own means is classed according to its limitations or likely hazards due to its use after the improvements are made. Land requiring improvements beyond the means of the farmer himself is classed according to its present condition.
3. Other factors like distances to markets, kind of roads, location, size of farms, type of ownership, cultural patterns, skill or resources of individual operators and hazard of crop damage by natural calamities like storms are not considered.

The classification does not include capability of soils for trees, tree fruits, small fruits, ornamental plants, recreation or wildlife. The classes are based on intensity, rather than kind of their limitations for agriculture. Each class includes many kinds of soil and many of the soils in any class require different management and treatment.

25.2 Land Capability Classes and their Characteristics

In this classification the mineral soils are grouped into seven classes on the basis of soil survey information. Soils classes as 1, 2, 3 and 4 are considered capable of sustained use for cultivated field crops, those in classes 5 and 6 only for perennial forage crops and those in class 7 for neither.

Class 1 - Soils in this class have no significant limitations in use for crops. The soils are deep, well to imperfectly drained, hold moisture well, and in the virgin state were well supplied with plant nutrients. They can be managed and cropped without difficulty. Under good management practices, they are moderately high to high in productivity for a wide range of field crops.

Class 2 - Soils in this class have moderate limitations that restrict the range of crops or require moderate conservation practices. The soils are deep and hold moisture well. The limitations being moderate, the soils can be managed and cropped with a little difficulty.

Under good management practices, they are moderately high to high in productivity for a fairly wide range of crops.

Class	Description
1	Soils in this class have no significant limitations in use for crops.
2	Soils in this class have moderate limitations that restrict the range of crops or require moderate conservation practices.
3	Soils in this class have moderately severe limitations that restrict the range of crops or require special conservation practices.
4	Soils in this class have severe limitations that restrict the range of crops or require special conservation practices.
5	Soils in this class have very severe limitations that restrict their capability in producing perennial forage crops, and improvement practices are feasible.
6	Soils in this class are capable only of producing perennial forage crops, and improvement practices are not feasible.
7	Soils in this class have no capacity for arable culture or permanent pasture.
0	Organic Soils (not placed in capability classes).

Fig. 25.1. Land Capability Classes. (Source: Dhillon, 2004)

Class 3 - Soils in this class have moderately severe limitations that restrict the range of crops or require special conservation practices. The limitations are more severe than for class 2 soils. They affect one or more of the following practices: timing and ease of tillage, planting and harvesting, choice of crops, and methods of conservation. Under good management they are fair to moderately high in productivity for a fair range of crops.

Class 4 - Soils in this class have severe limitations that restrict the range of crops or require special conservation practices or both. The limitations seriously affect one or more of the following practices: timing and ease of tillage, planting and harvesting, choice of crops and methods of conservation. The soils are low to fair in productivity for a fair range of crops but may have high productivity for a specially adapted crop.

Class 5 - Soils in this class have very severe limitations that restrict their capability to produce perennial forage crops and improvement practices are feasible. The limitations are so severe that soils are not capable of use for sustained production of annual field crops. The soils are capable of producing native or tame species of perennial forage plants and may be improved by the use of farm machinery. The improvement practices may include clearing of bush, cultivation, seeding, fertilizing and water control.

Class 6 - Soils in this class are capable only of producing perennial forage crops and improvement practices are not feasible. The soils provide some sustained grazing for farm animals, but the limitations are so severe that improvement by use of farm machinery is impractical. In this class, terrain may be unsuitable for use of farm machinery or the soils may not respond to improvement or the grazing season may be very short.

Class 7 - Soils in this class have no capability for arable culture or permanent pasture. This class also includes rock land, other non-soil areas, and bodies of water too small to be shown on the maps.

Class 0 - Organic soils (not placed in capability classes).

25.3 Land Capability Sub-Classes

Subclass Descriptions: Capability sub-class is the second category in the land capability classification system. It represents the soils physical, chemical or atmospheric limitation due to which the land use is further restricted. These land capability sub-classes can be described as below.

'c' Adverse Climate - This subclass denotes a significant adverse climate for crop production as 'median' climate which is defined as one with sufficiently high growing-season temperatures to bring crops to maturity.

'd' Undesirable Soil Structure and/or Low Permeability - This subclass indicates soils that are difficult to till or soils where water is absorbed very slowly or where the depth of rooting zone is restricted by conditions other than a high water table or consolidated bedrock.

'e' Erosion - This subclass includes soils where damage from erosion is a limitation to agricultural use. Damage is assessed on the loss of productivity and on the difficulties in farming land with gullies.

'f' Low Fertility - This subclass includes soils having low fertility that is either correctable with careful management with the use of fertilizers and soil amendments or is difficult to correct by any practical means. The limitations may be due to lack of plant nutrients, high acidity or alkalinity, low cation exchange capacity, high levels of carbonates or presence of toxic compounds.

'i' Inundation by Streams or Lakes - This subclass includes soils subjected to inundation causing crop damage or restricting agricultural use.

'm' Moisture Limitations - This subclass consists of soils where crops are affected by drought owing to inherent soil characteristics. These soils usually have low water-holding capacity.

'n' Salinity - Soils of this subclass possess excessive soluble salts which adversely affect crop growth or restrict the range of crops that may be grown.

'p' Stoniness - These soils are sufficiently stoney to hinder tillage, planting and harvesting operations.

'r' Consolidated Bedrock - This subclass includes soils where the presence of bedrock near the surface restricts their agricultural use. Consolidated bedrock at depths greater than 90 cm from the surface is not considered as a limitation except on irrigated lands where a greater depth of soil is desirable.

's' Two interpretations were accorded to subclass s. In the case of maps generally prepared before 1969, subclass s was used in place of subclasses d, f, m or n. If two or more of subclasses d, f, m or n are applicable to the same area, then again subclass s may be used. On most of the maps prepared after 1969, the applicable subclass d, f, m or n appear if an area is classified with a single subclass. For areas classified with two or more of the d, f, m or n subclasses, subclass s will appear denoting a combination of subclasses.

't' Topography - This subclass is made up of soils where topography is a limitation. Both the percent of slope and the pattern or frequency of slopes in different directions affect the cost of farming and the uniformity of growth and maturity of crops as well as creates erosion hazard.

'w' Excess Water - This subclass includes soils where excess water other than brought about by inundation is a limitation to agricultural use. Excess water may result from inadequate soil drainage, a high water table, seepage or runoff from surrounding areas.

'x' - This subclass is comprised of soils having a limitation resulting from the cumulative effect of two or more of the adverse characteristics.

25.4 Identification of Classes in Field

Soil and climatic limitations in relation to the use, management, and productivity of soils are the basis for differentiating capability classes. Classes are based both on the degree and number of limitations affecting the kind of use, risks of soil damage if mismanaged, needs for soil management and risks of crop failure. It comes from research findings, field trials and experiences of farmers and other agricultural workers. Among the more common kinds of information obtained are soil and water losses, kinds and number of plants that can be grown, weather conditions as they affect the plants and the effect of different levels of management practices on plant response. This information along with the laboratory data on soil profiles is analyzed. Careful analysis of this information proves useful not only in determining the capability of these individual types of soil but also in assessing the suitable use and management of the related soils. Where information on response of soils to management is lacking, the estimates of yields and the grouping of soils into capability units, sub-classes, and classes are based on an evaluation of combinations of the followings:

1. Ability of the soil for plant response due to management practices and use of nutrients as evident by the availability of organic-matter content, ease of maintaining a supply of plant nutrients, percentage base saturation, cation-exchange capacity, clay mineral type, parent material type, available water holding capacity, response to added plant nutrients, or other soil characteristics.
2. Texture and structure of the soil to the depth that influences the environment of roots and the movement of air and water.
3. Susceptibility to erosion as influenced by the kind of soil (and slope) and the effect of erosion on land use and management.
4. Continuous or periodic water logging in the soil caused by slow permeability of the underlying material, a high water table or flooding.
5. Depth of soil material to layers inhibiting root penetration.
6. Salts toxic to plant growth.
7. Physical obstacles such as rocks, deep gullies, etc.
8. Climate (temperature and effective moisture).

Although the soils of any area may differ from one another in only a few dozen characteristics, none can be taken for granted. Extreme deficiencies or excesses of trace

elements, for example, can be vital. Any unfavorable fixed or recurring soil or landscape features may limit the safe and productive use of the soil. One unfavorable feature in the soil may so limit its use that extensive treatment would be required. Several minor unfavorable features collectively may become a major problem and thus limit the use of the soil. The combined effect of these in relation to the use, management, and productivity of soils is the criterion for different capability units. Some of the criteria used to differentiate between the capability classes are discussed in the following sections. The criteria and ranges in characteristics suggested assume that the effects of other soil characteristics and qualities are favorable and are not limiting factors in placing the soils in the specific capability classes.

25.5 Arid and Semiarid, Stony, Wet, Saline-Sodic and Overflow Soils

The capability-class designations are assigned to soils subject to flooding, poorly or imperfectly drained soils, stony soils, dry soils needing supplemental water and soils having excess soluble salts or exchangeable sodium on the basis of continuing limitations and hazards after removal of excess water, stones, salts and exchangeable sodium.

The soils are classified into the following kinds on the basis of their existing continuing limitations and hazards:

1. Dry soils (arid and semiarid areas) now irrigated
2. Soils from which stones have been removed
3. Wet soils that have been drained
4. Soils from which excess quantities of soluble salts or exchangeable sodium have been removed
5. Soils that have been protected from overflow.

The soils are classified into the following kinds on the basis of their continuing limitations and hazards as if the correctable limitations had been removed or reduced:

1. Dry soils not irrigated now but for which irrigation is feasible and water is available
2. Stony soils for which stone removal is feasible
3. Wet soils not drained now but for which drainage is feasible,
4. Soils that contain excess quantities of soluble salts or exchangeable sodium feasible to remove

The soils are classified into the following kinds on the basis of their existing continuing limitations and hazards if the limitations cannot be feasibly corrected or removed:

1. Dry soils,
2. Stony soils,
3. Soils with excess quantities of saline and sodic salts,
4. Wet soils,
5. Soils subject to overflow

25.5 Climatic Limitations

Climatic limitations (temperature and moisture) affect capability. Extremely low temperatures and short growing seasons are limitations. Limited natural moisture supply affects the capability in sub humid, semiarid and arid climates. As the classification in any locality is derived in part from the observed performance of crop plants, the effects of the interaction of climate with soil characteristics must be considered. The capability of comparable soils decreases as effective rainfall decreases. In an arid climate, the moisture from rainfall is not enough to support crops. Arid land can be classed as suited to cultivation (class I, II, III or IV) only if the moisture limitation is removed by irrigation. Wherever the moisture limitation is removed, the soil is classified according to the effects of other permanent features and hazards that limit its use and permanence, without losing sight of the practical requirements of irrigation farming.

25.6 Wetness Limitations

Excess water in the soil presents a hazard or limits to its use. Such water may be a result of poor soil drainage, high water table, overflow (includes stream overflow, ponding, and runoff water from higher areas), and seepage. Wet soils are classified according to their continuing soil limitations and hazards after drainage. In determining the capability of wet areas, emphasis is laid on the practices considered practical now or in the foreseeable future.

25.7 Toxic Salts

Presence of soluble salts or exchangeable sodium in amounts toxic to most of the plants can be a serious limiting factor in land use. Where toxic salts are the limiting factor, the following ranges are the general guides until more specific criteria are available:

1. Class II -- Crops slightly affected.
2. Class III -- Crops moderately affected.
3. Classes IV-VI -- Crops seriously affected on cultivated land. Usually only salt-tolerant plants will grow on non-cultivated land. In irrigated areas, even after leaching, severe salinity or large amounts of sodium remains or is likely to recur.
4. Class VII -- Satisfactory growth of useful vegetation is impossible, except possibly for some of the most salt-tolerant forms.

25.8 Slope and Hazard of Erosion

The steepness of slope, length of slope and shape of slope (convex or concave) all directly influence the soil and water losses from a field. Wherever available, research data on annual soil loss under given levels of management are used on sloping soils to differentiate between the capability classes.

25.9 Soil Depth

Effective depth includes the total depth of the soil profile favorable for root development. In some soils, this includes the C horizon; in a few case only the A horizon is included. Where the depth is the limiting factor, the following ranges are commonly used:

1. Class I, 36 inches (91.44 cm) or more

2. Class II, 20-36 inches (50.8 - 91.44 cm)
3. Class III, 10-20 inches (25.4 - 50.8 cm)
4. Class IV, less than 10 inches (25.4 cm)

These ranges in soil depth between classes vary from one section of the country to another depending on the climate. In arid and semiarid areas, irrigated soils in class I are 60 inches or more in depth.

25.10 Previous Erosion

On some kinds of soils, previous erosion reduces crop yields and the choice of crops materially; on others the effect is not great. The effect of past erosion limits the use of soils (1) where subsoil characteristics are unfavorable or (2) where soil material favorable for plant growth is shallow to bedrock or material similar to bedrock. Therefore, in some soils, the degree of erosion influences the capability grouping.

25.11 Available Moisture-Holding Capacity

Water-holding capacity is an important quality of soil. Soils that have limited moisture-holding capacity are likely to have limitations in variety of crops that can be grown. They also present fertility and other management problems. The ranges in water-holding capacity for the soils in the capability classes vary to a limited degree with the amount and distribution of effective precipitation during the growing season. Within a capability class, the range in available moisture-holding capacity varies from one climatic region to another.



Lesson 26 Land Evaluation and Improvement

Land evaluation is concerned with present land performance. Frequently however, it involves change and its effects, with change in the use of land and in some cases change in the land itself.

26.1 Definition of Land Evaluation and Difference between Land Evaluation and Land Capability Classification (LCC).

Land evaluation is formally defined as 'the assessment of land performance when used for a specified purpose, involving the execution and interpretation of surveys and studies of land forms, soils, vegetation, climate and other aspects of land in order to identify and make a comparison of promising kinds of land use in terms applicable to the objectives of the evaluation'. Land evaluation can be a key tool for land use planning, either by individual land users (e.g., farmers), by groups of land users (e.g., cooperatives or villages), or by society as a whole (e.g., as represented by the governments). There is a diverse set of analytical techniques which may be used to describe land uses, to predict the response of land to these both in physical and economic terms, and to optimize land use in the face of multiple objectives and constraints. Land evaluation should also be distinguished from land capability based classification as used, where land capability is based primarily on an assessment of soil conditions to support common cultivated crops and pasture plants. The land-evaluation approach, on the other hand, additionally takes into account specific crops and aspects related to land-management and socio-economic setting.

Land evaluation provides practical answers to such questions as

1. What other uses of land are physically possible and economically and socially relevant?
2. What inputs are necessary to bring about a desired level of production?
3. What are the current land uses and what are the consequences if current management practices stay the same?

26.2 Land Evaluation Framework

The range of possible uses of land and purposes of evaluation is so wide that no one system could hope to take into account all of them. Besides such obvious contrasts as those of climate; differences in the availability and cost of labour, availability of capital, population density and levels of living will all cause differences detail and emphasis in the evaluation of land.

It was recognition of this situation, coupled with the need for some degree of standardization or compatibility which led to the concept of the Framework for Land Evaluation. The framework does not by itself constitute an evaluation system. The framework sets out a number of principles involved in land evaluation, some basic concepts, the structure of a suitability classification and the procedures necessary to carry out a land suitability evaluation at local, national or regional scales.

Principles of the Food and Agriculture Organization (FAO) Framework for Land Evaluation:

1. Land suitability should be assessed and classified with respect to specified kinds of land use and services.
2. Land evaluation requires a comparison of the benefits obtained and the inputs needed on different types of lands to assess the productive potential, environmental services and sustainable livelihood.
3. Land evaluation requires a multi-disciplinary and cross-sectoral approach.
4. Land evaluation should take into account the biophysical, economic, social and political context as well as the environmental concerns.
5. Suitability refers to use or services on a sustained basis; sustainability should incorporate productivity, social equity and environmental concerns.
6. Land evaluation involves a comparison of more than one kind of use or service.
7. Land evaluation needs to consider all stakeholders.
8. The scale and the level of decision-making should be clearly defined prior to the land evaluation process.

The principles and procedures given in the Framework can be applied in all parts of the world. They are relevant both to less developed and developed countries. At one extreme, they can be applied to areas where development planning is being applied to the more or less unaltered natural environment; on the other, to densely populated lands where the main concern of planning is to reconcile the competing demands for land already under various forms of use. The Framework can be used to construct systems applicable at all levels of intensity ranging from, at one extreme, national, continental or world-scale assessment, and at the other to detailed local studies. The Framework covers all kinds of rural land use: agriculture in its broadest sense, including livestock production, together with forestry, recreation or tourism, and nature conservation. Engineering aspects involved in rural land use, such as foundation suitability for roads or small structures are also included. The Framework is not intended for the distinct set of planning procedures involved in urban land use planning, although some of its principles are applicable in these contexts. Nor does the Framework take into account the resources of the seas. Water on and beneath the surface of the land is, however, of relevance in land evaluation. The FAO advocates decision-support systems, in which physical land evaluation and socio-economic evaluation run parallel for planning of sustainable use of land resources (see Fig. 26.1.)

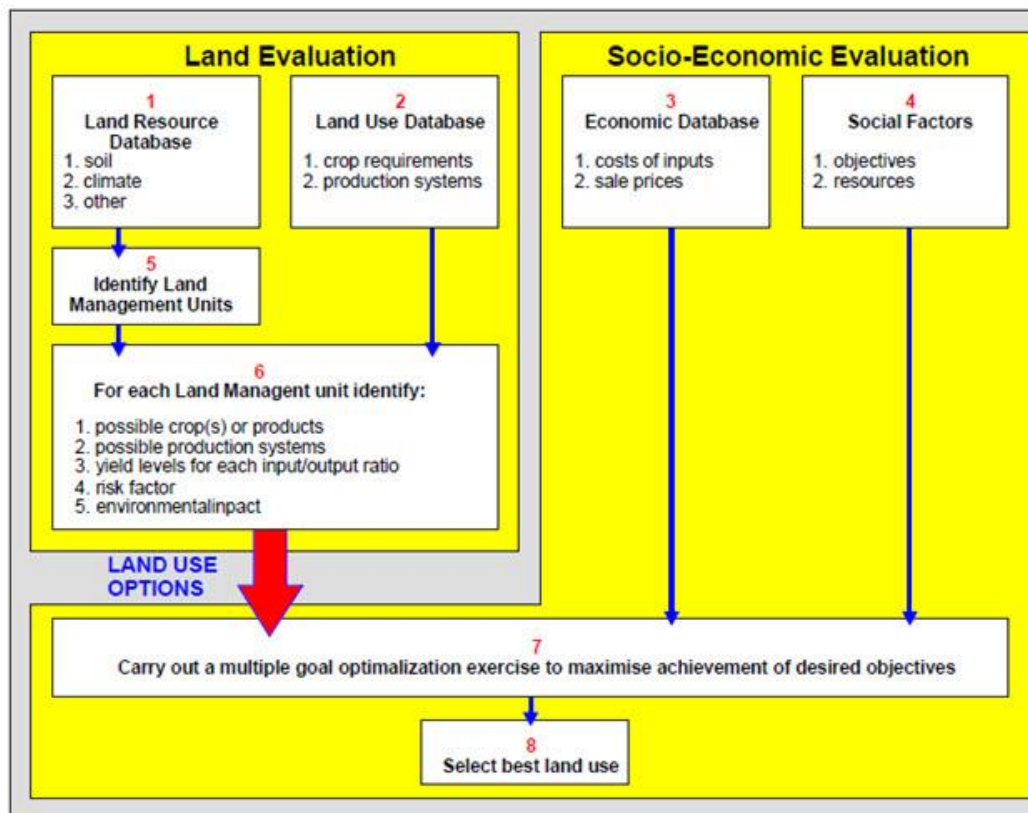

Fig. 26.1. Decision Support System for Land Use Planning.

This Framework is written mainly for those actively involved in rural land evaluation. Since most land suitability evaluations are at present carried out for the purposes of planning by national and local governments, this situation is assumed in references to decision-making, but the evaluation can also be applied to land use planning by firms, farmers or other individuals. The principles and procedures which are set out can be applied either to land evaluation for individual land development projects or to the construction of local or national evaluation systems.

26.3 Land Degradation

The risk of land degradation stands at the root of land evaluation. Land degradation is damage to land that makes it economically less useful and biologically less diverse. Degradation of the natural environment is a worldwide problem, and some examples are quite ancient. This term is used specifically to refer to damages caused by human activities rather than natural ones, and human activities can indirectly contribute to environmental changes that may accelerate the speed of land degradation. In land degradation, land that was once rich in nutrients and able to support diverse organisms becomes compromised. Some types of degradations include development of salinity and acidification of soils, topsoil loss, soil compaction and pollution of land due to which it becomes unusable. The more degraded the soil becomes, the less it can support. This can cause degradation to speed up, as plants and animals that would normally help restore the soil are unable to survive.

Natural causes often determine the inherent capacity of the ecosystem to provide goods and services. They include the factors related to climatic condition, availability of water in adequate quantities, the capacity to generate biomass, provide ground cover and biodiversity. Some natural causes such as slope and soil vulnerability to water and wind erosion also influence the degradation processes.

Human-induced causes of land degradation processes are largely determined by land use and land-use change, economic factors related to the possibility of investing in the land and access to markets; and social factors that assure the availability of infrastructure, and farmers' accessibility to land that allows them to produce at maximum capacity. Agricultural practices are common culprit in land degradation. Overworking the soil can damage it, sometimes permanently. Degradation can also be the result of overutilization of timber resources that de-stabilizes the ecosystem. As the trees are cut down, the organisms they support are no longer able to survive. The land and soil face many difficulties like deforestation, erosion, flooding, water logging, urbanization and salination. Soil erosion occurs everywhere in the world. It is more common in the Australia, India, Spain, U.S.A and Africa where air and water erosions affect around 40 thousand hectares of land annually. Apart from the direct and obvious causes of human induced land degradation, there are often other more deeply rooted drivers that have serious repercussion. They include population pressure, poverty, lack of markets and infrastructure, poor governance and weak institutional frameworks and inadequate education.

Land degradation is more than an environmental problem alone and should be considered holistically taking into account different ecosystem goods and services, biophysical as well as socio-economic. Results should be referred to a given time period and solutions require full consultation with stakeholders and imply trade-offs between environmental and socioeconomic ecosystem services. Degraded land, based on the capacity of the globe's ecosystem to deliver goods and services are highly variable. Degraded land mostly occurs in dry and steep lands which deserve special attention. Degradation takes many forms and it affects soils, availability of biomass, water, biodiversity, economics and social services derived from the ecosystem. This decline (degradation) appears to be proportional to the present capacity of the system. In other words ecosystems with lower capacities decline at a less rate than the ecosystems with greater capacities. The impact of this degradation is most felt in areas with a high incidence of poverty. This implies that even when starting from a low resource base, the lower rate of degradation in these areas has a much greater impact, compared to the ecosystems with a higher capacity, with a higher rate of degradation, but with fewer poor people.

The process of restoring land that has become degraded is known as remediation. In remediation, people identify the causes of the land degradation and explore the methods for reversing it. Usually remediation takes time, as scientists want to encourage the land and ecosystem to rebuild and become stable again rather than enacting a quick fix. In some cases, land is too badly degraded for remediation to be effective, forcing human populations that relied on the land to relocate in order to access new resources. This in turn can contribute to population pressures in other fragile environments, ultimately repeating the land degradation all over again.

26.4 Land Improvement

Land improvements are activities which cause beneficial changes in the qualities of the land itself. Land improvements should be distinguished from improvements in land use. Land improvements are classed as major or minor. A major land improvement is a substantial and reasonably permanent improvement in the qualities of the land affecting a given use. A large non-recurrent input is required, usually taking the form of capital expenditure on structure and equipment. Once accomplished, maintenance of the improvement remains as a continuing cost, but the land itself is more suitable for the use than before. Examples are large irrigation schemes, drainage of swamps and reclamation of salinized land.

A minor land improvement is one which has either relatively small effects or is non-permanent or both, or which lies within the capacity of individual farmers or other land users. Stone clearance, eradication of persistent weeds and field drainage by ditches are some of the examples. The separation of major from minor land improvements is intended only as an aid to making a suitability classification. The distinction is a relative one, that is, it is not clear-cut and is only valid within a local context. In cases of doubt, the main criterion is whether the improvement is within the technical and financial capacity of individual farmers or other landowners. In many areas improvements such as subsoiling, dynamiting or terracing cannot be undertaken by individual farmers, and are therefore regarded as major land improvements. In countries with large farms and high capital resources coupled with good credit facilities, however, these changes may be within the reach of individuals and are therefore considered as minor improvements. Field drainage is another improvement that may or may not be regarded as major, depending on farm size, permanency of tenure, capital availability and level of technology.



AGRIMOON.COM

All About Agriculture...

Module 8: Grassed Waterways

Lesson 27 Grassed Waterways

Grassed waterways are natural or man made constructed channels established for the transport of concentrated flow at safe velocities from the catchment using adequate erosion resistant vegetation which cover the channels. These channels are used for the safe disposal of excess runoff from the crop lands to some safe outlet, namely rivers, reservoirs, streams etc. without causing soil erosion. Terraced and bunded crop lands, diversion channels, spillways, contour furrows, etc. from which excess runoff is to be disposed of, preferably use constructed grassed waterways for safe disposal of the runoff. The grassed waterways outlets are constructed prior to the construction of terraces, bunds etc. because grasses take time to get established on the channel bed. Generally, it is recommended that there should be a gap of one year so that the grasses can be established during the rainy season.

27.1 Purpose of Grassed Waterways

Grassed waterways are used as outlets to prevent rill and gully formation. The vegetative cover slows the water flow, minimizing channel surface erosion. When properly constructed, grassed waterways can safely transport large water flows to the down slope. These waterways can also be used as outlets for water released from contoured and terraced systems and from diverted channels. This best management practice can reduce sedimentation of nearby water bodies and pollutants in runoff. The vegetation improves the soil aeration and water quality (impacting the aquatic habitat) due to its nutrient removal (nitrogen, phosphorus, herbicides and pesticides) through plant uptake and sorption by soil. The waterways can also provide a wildlife habitat.

27.2 Design of Grassed Waterways

The designs of the grassed waterways are similar to the design of the irrigation channels and are designed based on their functional requirements. Generally, these waterways are designed for carrying the maximum runoff for a 10- year recurrence interval period. The rational formula is invariably used to determine the peak runoff rate. Waterways can be shorter in length or sometimes, can be even very long. For shorter lengths, the estimated flow at the waterways outlets forms the design criterion, and for longer lengths, a variable capacity waterway is designed to account for the changing drainage areas.

27.2.1 Size of Waterway

The size of the waterway depends upon the expected runoff. A 10 year recurrence interval is used to calculate the maximum expected runoff to the waterway. As the catchment area of the waterway increases towards the outlet, the expected runoff is calculated for different reaches of the waterway and used for design purposes. The waterway is to be given greater cross-sectional area towards the outlet as the amount of water gradually increases towards the outlet. The cross-sectional area is calculated using the following formula:

$$a = \frac{Q}{V} \quad (27.1)$$

where, a = cross-sectional area of the channel,

Q = expected maximum runoff, and

V = velocity of flow.

27.2.2 Shape of Water Way

The shape of the waterway depends upon the field conditions and type of the construction equipment used. The three common shapes adopted are trapezoidal, triangular, and parabolic shapes. In course of time due to flow of water and sediment depositions, the waterways assume an irregular shape nearing the parabolic shape. If the farm machinery has to cross the waterways, parabolic shape or trapezoidal shape with very flat side slopes are preferred. The geometric characteristics of different waterways are shown in Fig. 27.1 and Fig. 27.2 for trapezoidal and parabolic waterways respectively.

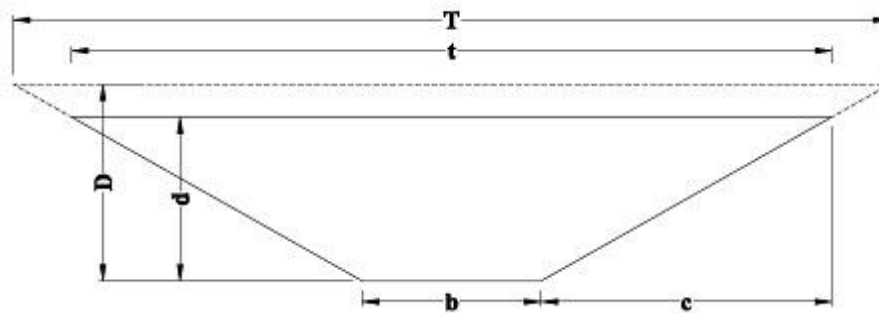

Fig. 27.1. Trapezoidal Cross-section. (Source: Murty, 2009)

In the figure, d is the depth of water flow, b is bottom width, t is the top width of maximum water conveyance, T is top width after considering free board depth, $(D - d)$ is the free board and slope (z) is c/d .

The design dimensions for trapezoidal and parabolic waterways are given in Tables 27.1 and 27.2 respectively.

Table 27.1. Design Dimensions for Trapezoidal Cross-section

Cross-sectional Area, a	Wetted perimeter, P	Hydraulic Radius, $R = \frac{a}{p}$	Top width
$bd + zd^2$ Where, $Z = c/d$	$b + 2d\sqrt{Z^2 + 1}$	$\frac{bd + zd^2}{b + 2d\sqrt{z^2 + 1}}$	$T = b + 2dz$ $T = b + 2Dz$

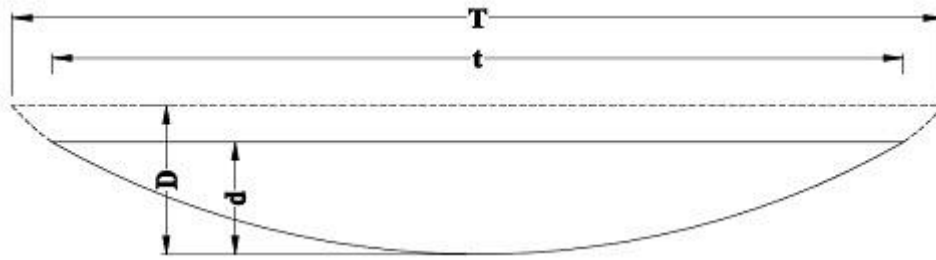

Fig. 27.2. Parabolic Cross-section. (Source: Murty, 2009)

Table 27.2. Design Dimensions for Parabolic Cross-Section

Cross-sectional Area, a	Wetted perimeter, P	Hydraulic Radius, $R = \frac{a}{p}$	Top width
$\frac{2}{3}td$	$t + \frac{8d^2}{3t}$	$\frac{t^2 \times d}{1.5t^2 + 4d^2}$	$t = \frac{a}{0.67d}$
		$\frac{2d}{3} \text{ approx}$	$T = t \left(\frac{D}{d}\right)^{\frac{1}{2}}$

27.2.3 Channel Flow Velocity

The velocity of flow in a grassed waterway is dependent on the condition of the vegetation and the soil erodibility. It is recommended to have a uniform cover of vegetation over the channel surface to ensure channel stability and smooth flow. The velocity of flow through the grassed waterway depends upon the ability of the vegetation in the channel to resist erosion. Even though different types of grasses have different capabilities to resist erosion; an average of 1.0 m/sec to 2.5 m/sec are the average velocities used for design purposes. It may be noted that the average velocity of flow is higher than the actual velocity in contact with the bed of the channel. Velocity distribution in a grassed lined channel is shown in Fig. 27.3. Recommended velocities of flow based on the type of vegetation are shown in Table 27.3. The permissible velocities of flow on different types of soils are given in table 27.4.

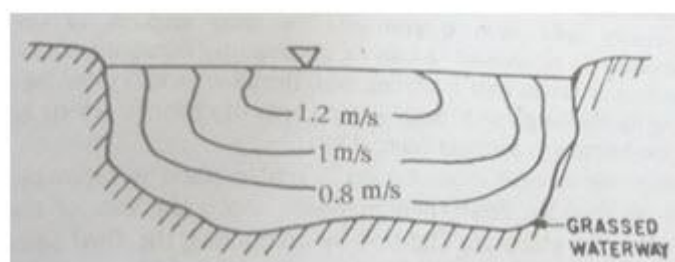

Fig. 27. 3. Velocity Distribution in Open Channel (Source: Murty, 2009)

Table 27.3. Recommend Velocities of Flow in a Vegetated Channel.

Type of vegetation cover	Flow velocity, (m/s)	
	Type	Magnitude
Spare green cover	Low velocity	1-1.15
Good quality cover	Medium velocity	1.5-1.8
Excellent quality cover	High velocity	1.8-2.5

Table 27.4. Permissible Velocity of Flow on Different Types of Soil.

Type of soil	Permissible velocity, (m/s)	
	Clean water	Colloidal water
Very fine sand	0.45	0.75
Sandy loam	0.55	0.75
Silty loam	0.60	0.90
Alluvial silt without colloids	0.60	1.00
Dense clay	0.75	1.00
Hard clay, colloidal	1.10	1.50
Very hard clay	1.80	1.80
Fine gravel	0.75	1.50
Medium and coarse gravel	1.20	1.80
Stones	1.50	1.80

27.2.4 Design of Cross-Section

The design of the cross-section is done using Equation 27.1 for finding the area required and Manning's formula is used for cross checking the velocity. A trial procedure is adopted. For required cross-sectional area, the dimensions of the channel section are assumed. Using hydraulic property of the assumed section, the average velocity of flow through the channel cross-section is calculated using the Manning's formula as below:

$$V = \frac{S^{1/2} R^{2/3}}{n} \quad (27.2)$$

where, V = velocity of flow in m/s; S = energy slope in m/m; R = hydraulic mean radius of the section in m and n = Manning's roughness coefficient.

The Manning's roughness coefficient is to be selected depending on the existing and proposed vegetation to be established in the bed of the channel. Velocity is not an independent parameter. It will depend on n which is already fixed according to vegetation, R which is a function of the channel geometry and slope S for uniform flow. Slope S has to be adjusted. If the existing land slope gives high velocity, alignment of the channel has to be changed to get the desired velocity.

Problem 27.1: Design a grassed waterway of parabolic shape to carry a flow of $2.6 \text{ m}^3/\text{s}$ down a slope of 3 percent. The waterway has a good stand of grass and a velocity of 1.75 m/s can be allowed. Assume the value of n in Manning's formula as 0.04 .

Solution: Using, $Q = AV$ for a velocity of 1.75 m/s , a cross-section of $2.6/1.75 = 1.485 \text{ m}^2$ ($\sim 1.5 \text{ m}^2$) is needed.

Assuming, $t = 4 \text{ m}$, $d = 60 \text{ cm}$.

$$A = \frac{2}{3}t \times d = \frac{2}{3}4 \times 0.6 = 1.6 \text{ m}^2$$

$$P = t + 8 \frac{d^2}{3t} = 4 + 8 \frac{(0.6)^2}{3 \times 4} = 4.24 \text{ m}$$

$$R = \frac{A}{P} = \frac{1.6}{4.24} = 0.377 \text{ m}$$

$$V = \frac{S^{1/2} R^{2/3}}{n} = \frac{(0.03)^{1/2} \times (0.377)^{2/3}}{0.04} = 2.26 \text{ m/s}$$

The velocity exceeds the permissible limit. Assuming a revised

$t = 6 \text{ m}$ and $d = 0.4 \text{ m}$

$$A = \frac{2}{3}t \times d = \frac{2}{3}4 \times 0.6 = 1.6 \text{ m}^2$$

$$P = t + 8 \frac{d^2}{3t} = 6 + 8 \frac{(0.4)^2}{3 \times 6} = 6.45 \text{ m}$$

$$V = \frac{S^{1/2} R^{2/3}}{n} = \frac{(0.03)^{1/2} \times (0.248)^{2/3}}{0.04} = 1.70 \text{ m/s}$$

The velocity is within the permissible limit.

$$Q = 1.6 \times 1.7 = 2.72 \text{ m}^3/\text{s}$$

The carrying capacity (Q) of the waterway is more than the required. Hence, the design of waterway is satisfactory. A suitable freeboard to the depth is to be provided in the final dimensions.

27.2.5 Construction of the Waterways

It is advantageous to construct the waterways at least one season before the bunding. It will give time for the grasses to get established in the waterways. First, unnecessary vegetation like shrubs etc. are removed from the area is marked for the waterways. The area is then ploughed if necessary and smoothed. Establishment of the grass is done either by seeding or sodding technique. Maintenance of the waterways is important for their proper operation. Removal of weeds, filling of the patches with grass and proper cutting of the grass are of the common maintenance operations that should be followed for an efficient use of waterways.

27.3 Selection of Suitable Grasses

The soil and climate conditions are the primary factors in selection of vegetations to be established for construction of grassed waterways. The other factors to be considered for selection of suitable grasses are duration of establishment, volume and velocity of runoff, ease of establishment and time required to develop a good vegetative cover. Furthermore, the suitability of the vegetation for utilization as feed or hay, spreading of vegetation to the adjoining fields, cost and availability of seeds and redundancy to shallow flows in relation to the sedimentation are the important factors that should be considered for the selection of vegetation.

Generally, the rhizomatous grasses are preferred for the waterway, because they get spread very quickly and provide more protection to the channel than the brush grasses. Deep rooted legumes are seldom used for grassed waterways, because they have the tendency to loosen the soil and thus make the soil more erodible under the effect of fast flowing runoff water. Sometimes, a light seeding of small grain is also used to develop a quick cover before the grasses are fully established in the waterway.

27.4 Construction Procedure and Maintenance

Ordinary tools such as slip scraper can be easily used for construction of waterways. However, the use of grader blade or a bulldozer can be preferred, particularly when a considerable earth movement is needed. Since the channel is prone to erosion before

vegetations are established, it is very essential to construct the waterway when the field is in meadow and the amount of runoff from the area is also very less. In addition, if the erosion hazard is very high, then runoff should also be essentially diverted from the waterway until a good grassed cover is developed in the waterway.

The construction of grassed waterways is carried out using the following steps.

Step-1: Shaping (Soil Digging)

The shaping of the waterway should be done as straight and even as possible. Any sudden fall or sharp turn must be eliminated, except in the area where the structure is planned to be installed in the waterway. In addition, the grade should also be shaped according to the designed plan. Also, the stones and stumps which are likely to interfere with the discharge rate must be removed.

Step-2: Grass Planting

After shaping the waterway channel, the planting of grasses is very important. Priorities should always be given to the local species of grasses. The short forming or rhizome grasses are more preferable as compared to the tall bunch type grasses.

In large waterways, the seeding is cheaper than the sodding. Therefore, the seeding should be preferred for grass development. It is also suggested that the seeded area should be mulched especially for production purposes. Immediately after grass planting, the waterways should not be allowed for runoff flow.

Step 3: Ballasting

Ballasting is done in those localities where rocks are readily available adjacent to the sites and waterway gradient is very steep. Ballasting is generally recommended for the waterways in the small farms. The stones to be used for this purpose should be at least of 15 to 20 cm diameter; and they should be placed firmly on the ground. From stability point of view, on very steep slopes, wire mesh should be used to encase the stones. In parabolic shaped waterways, partial ballasting should be done in the centre, leaving the sides with grass protection.

Step 4: Placing of Structure

Structures (drop) are essential if there is sudden fall in the waterway flow path. Because under this situation, there is a possibility of soil scouring due to falling of water flow from a higher elevation to a lower elevation. For eliminating this problem, the constructed structure must be sufficiently strong to handle the designed flows successfully. As a precautionary measure, care should be taken to see that the water must not flow from the below or around the structure but through the top of the structure. In addition, the structure should be constructed on firm soils with strong and deep foundation. The apron or stilling basin of drop structures should be sufficiently strong and able to absorb or dissipate the energy/impact of falling water. After construction, earth filling should be done around the structure and it should be properly consolidated to prevent further settlement. Proper sodding should also be provided at the junction of earth filling and the structure to prevent tunneling.

27.4.1 Maintenance

The grasses grown in waterway should always be kept short and flexible, so that they shingle as water flows over them, but do not lodge permanently. For this purpose, the grass should be mowed two to three times in a year. The mowed grasses must be removed from the waterway, so that they do not get accumulated at some spots in the waterway and also should not obstruct the flow. The deposition of mowed grasses in the section of the waterway reduces the flow capacity of the waterway and also diverts the direction of flowing water which can cause turbulence and thus damage of the channel. It is also possible to keep the grasses short by light pasturing, which should not be done in wet condition. When the grass is pastured, it is necessary to apply manure to discourage grazing. The waterway should not be used as a road for livestock. After the vegetative cover is established and runoff passes through them for a long time, a light application of fertilizer should be done because the flowing runoff removes the plant food from the soil of waterway.

Similarly, if waterways are to be crossed by tillage implements, they should be disengaged, plough should be lifted and disc straightened. Tillage operation should also be done following nearly the contour. The waterway and its sides should not be touched during tillage operation. It is also essential that if there is any damage of the waterway, it should be quickly repaired so that the damage may not enlarge due to rainfalls. Overall, it should always be remembered that the waterways are an integral part of watershed conservation or land treatment system. If they fail to handle the peak discharge due to lack of proper maintenance, then the prolong flow of runoff through them can develop gullies in the area. Briefly, the maintenance of waterways can be taken up using the following process.

- a) The outlets should be safe and open so as not to impede the free flow.
- b) Grassed waterways should not be used as footpaths, animal tracks, or as grazing grounds.
- c) Frequent crossing of waterways by wheeled vehicles should not be allowed.
- d) Newly established waterways should be kept under strict watch.
- e) The large waterways should be kept under protection with fencing.
- f) Waterways must be inspected frequently during first two rainy seasons, after construction.
- g) If there is any break in the channel or structures, then they should be repaired immediately.
- h) The bushes or large plants grown in the waterway should be removed immediately as they may endanger the growth of grasses.
- i) The level of grass in waterway should be kept as low and uniform as possible to avoid turbulent flow.

Module 9: Water Harvesting

Lesson 28 Water Harvesting

28.1 Importance of Water Harvesting

Rainwater harvesting, in its broadest sense, is a technology used for collecting and storing rainwater for human use from rooftops, land surfaces or rock catchments using simple techniques such as jars and pots as well as engineered techniques. Rainwater harvesting has been practiced for more than 4,000 years, owing to the temporal and spatial variability of rainfall. It is an important water source in many areas with significant rainfall but lacking any kind of conventional, centralised supply system. It is also a good option in areas where good quality fresh surface water or ground water is lacking. Water harvesting enables efficient collection and storage of rainwater, makes it accessible and substitute for poor quality water. There are a number of ways by which water harvesting can benefit a community.

- Improvement in the quality of ground water,
- Rise in the water levels in wells and bore wells that are drying up,
- Mitigation of the effects of drought and attainment of drought proofing,
- An ideal solution in areas having inadequate water resources,
- Reduction in the soil erosion as the surface runoff is reduced,
- Decrease in the choking of storm water drains and flooding of roads and
- Saving of energy to lift ground water.

28.2 Types of Water Harvesting

Rainwater Harvesting: Rainwater harvesting is defined as the method for inducing, collecting, storing and conserving local surface runoff for agriculture in arid and semi-arid regions. Three types of water harvesting are covered by rainwater harvesting.

- Water collected from roof tops, courtyards and similar compacted or treated surfaces is used for domestic purpose or garden crops.
- Micro-catchment water harvesting is a method of collecting surface runoff from a small catchment area and storing it in the root zone of an adjacent infiltration basin. The basin is planted with a tree, a bush or with annual crops.
- Macro-catchment water harvesting, also called harvesting from external catchments is the case where runoff from hill-slope catchments is conveyed to the cropping area located at foothill on flat terrain.

Flood Water Harvesting: Flood water harvesting can be defined as the collection and storage of creek flow for irrigation use. Flood water harvesting, also known as 'large catchment water harvesting' or 'Spate Irrigation', may be classified into following two forms:

- In case of 'flood water harvesting within stream bed', the water flow is dammed and as a result, inundates the valley bottom of the flood plain. The water is forced to infiltrate and the wetted area can be used for agriculture or pasture improvement.
- In case of 'flood water diversion', the wadi water is forced to leave its natural course and conveyed to nearby cropping fields.

Groundwater Harvesting: Groundwater harvesting is a rather new term and employed to cover traditional as well as unconventional ways of ground water extraction. Qanat systems, underground dams and special types of wells are a few examples of the groundwater harvesting techniques. Groundwater dams like 'Subsurface Dams' and 'Sand Storage Dams' are other fine examples of groundwater harvesting. They obstruct the flow of ephemeral streams in a river bed; the water is stored in the sediment below ground surface and can be used for aquifer recharge.

28.3 Water Harvesting Technique

This includes runoff harvesting, flood water harvesting and groundwater harvesting.

28.3.1 Runoff Harvesting

Runoff harvesting for short and long term is done by constructing structures as given below.

28.3.1.1 Short Term Runoff Harvesting Techniques

Contour Bunds: This method involves the construction of bunds on the contour of the catchment area (Fig. 28.1). These bunds hold the flowing surface runoff in the area located between two adjacent bunds. The height of contour bund generally ranges from 0.30 to 1.0 m and length from 10 to a few 100 meters. The side slope of the bund should be as per the requirement. The height of the bund determines the storage capacity of its upstream area.

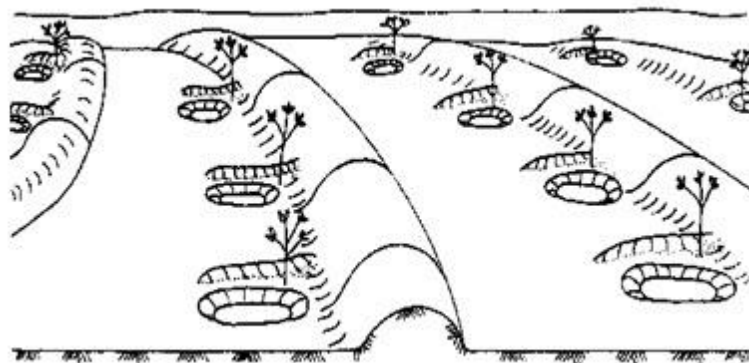

Fig. 28.1. Contour Bunds. (Source: Barron and Salas, 2009)

Semicircular Hoop: This type of structure consists of an earthen impartment constructed in the shape of a semicircle (Fig. 28.2). The tips of the semicircular hoop are furnished on the contour. The water contributed from the area is collected within the hoop to a maximum depth equal to the height of the embankment. Excess water is discharged from the point around the tips to the next lower hoop. The rows of semicircular hoops are arranged in a

staggered form so that the overflowing water from the upper row can be easily interrupted by the lower row. The height of hoop is kept from 0.1 to 0.5 m and radius varies from 5 to 30 m. Such type of structure is mostly used for irrigation of grasses, fodder, shrubs, trees etc.

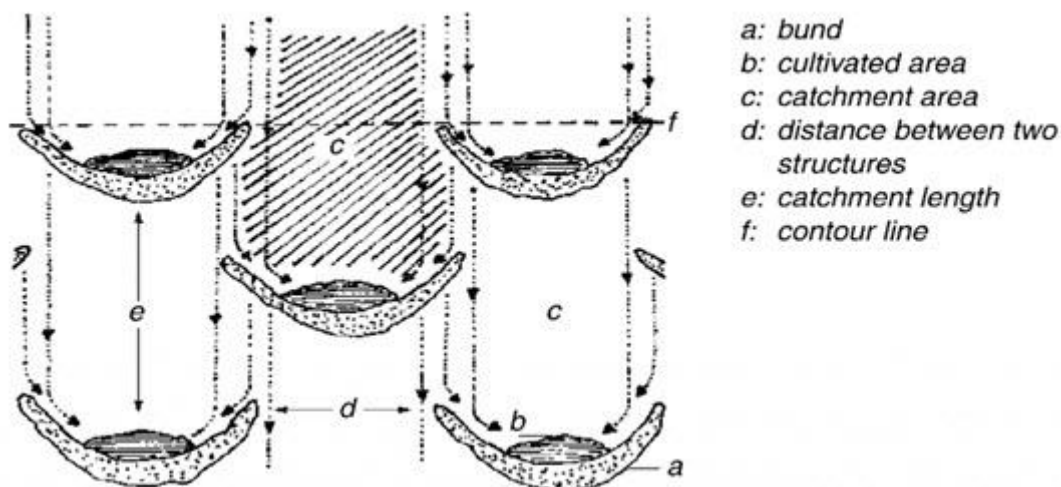

Fig. 28.2. Layout of Semi-Circular Hoop. (Source: Barron and Salas 2009)

Trapezoidal Bunds: Such bunds also consist of an earthen embankment, constructed in the shape of trapezoids. The tips of the bund wings are placed on the contour. The runoff water yielded from the watershed is collected into the covered area. The excess water overflows around the tips. In this system of water harvesting the rows of bunds are also arranged in staggered form to intercept the overflow of water from the adjacent upstream areas. The layout of the trapezoidal bunds is the same as the semicircular hoops, but they unusually cover a larger area (Fig. 28.3). Trapezoidal bund technique is suitable for the areas where the rainfall intensity is too high and causes large surface flow to damage the contour bunds. This technique of water harvesting is widely used for irrigating crops, grasses, shrubs, trees etc.

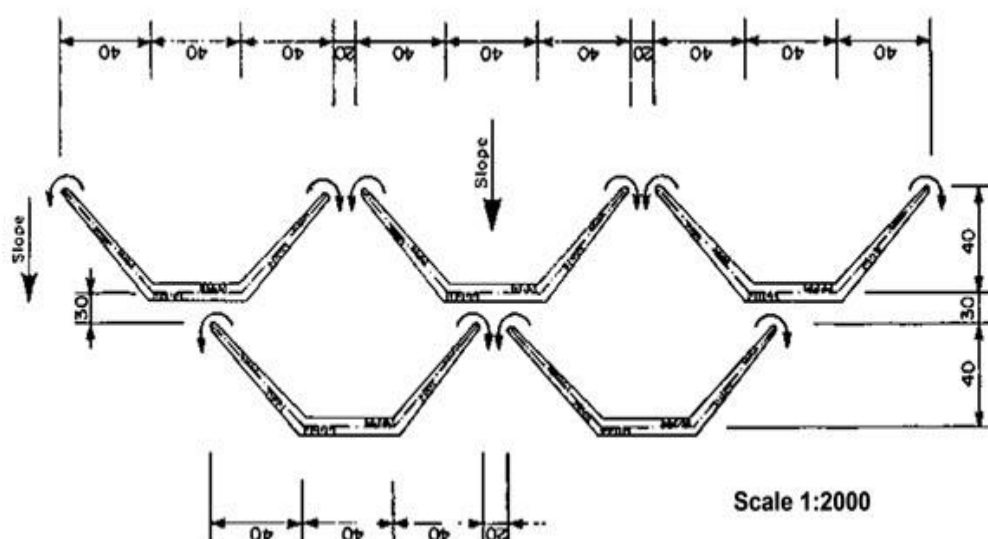

Fig. 28.3. Layout of Trapezoidal Bund. (Source: Barron and Salas, 2009)

Graded Bunds: Graded bunds also referred as off contour bunds. They consist of earthen or stone embankments and are constructed on a land with a slope range of 0.5 to 2%. The design and construction of graded bunds are different from the contour bunds. They are used as an option where rainfall intensity and soils are such that the runoff water discharged

from the field can be easily intercepted. The excess intercepted or harvested water is diverted to the next field through a channel ranges. The height of the graded bund ranges from 0.3 to 0.6 m. The downstream bunds consist of wings to intercept the overflowing water from the upstream bunds. Due to this, the configuration of the graded bund looks like an open ended trapezoidal bund. That is why sometimes it is also known as modified trapezoidal bund. This type of bunds for water harvesting is generally used for irrigating the crops.

Rock Catchment: The rock catchments are the exposed rock surfaces, used for collecting the runoff water in a part as depressed area. The water harvesting under this method can be explained as: when rainfall occurs on the exposed rock surface, runoff takes place very rapidly because there is very little loss. The runoff so formed is drained towards the lowest point called storage tank and the harvested water is stored there. The area of rock catchment may vary from a 100 m² to few 1000 m²; accordingly the dimensions of the storage tank should also be designed. The water collected in the tank can be used for domestic use or irrigation purposes.

Ground Catchment: In this method, a large area of ground is used as catchment for runoff yield. The runoff is diverted into a storage tank where it is stored. The ground is cleared from vegetation and compacted very well. The channels are as well compacted to reduce the seepage or percolation loss and sometimes they are also covered with gravel. Ground catchments are also called roaded catchments. This process is also called runoff inducement. Ground catchments have also been traditionally used since last 4000 years in the Negev (a desert in southern Israel) where annual crops and some drought tolerant species like pistachio dependent on such harvested water are grown.

28.3.1.2 Long Term Runoff Harvesting Techniques

The long term runoff harvesting is done for building a large water storage for the purpose of irrigation, fish farming, electricity generation etc. It is done by constructing reservoirs and big ponds in the area. The design criteria of these constructions are given below.

- Watershed should contribute a sufficient amount of runoff.
- There should be suitable collection site, where water can be safely stored.
- Appropriate techniques should be used for minimizing various types of water losses such as seepage and evaporation during storage and its subsequent use in the watershed.
- There should also be some suitable methods for efficient utilization of the harvested water for maximizing crop yield per unit volume of available water.

The most common long term runoff harvesting structures are:

- Dugout Ponds
- Embankment Type Reservoirs

Dugout Ponds: The dugout ponds are constructed by excavating the soil from the ground surface. These ponds may be fed by ground water or surface runoff or by both. Construction of these ponds is limited to those areas which have land slope less than 4% and where water table lies within 1.5-2 meters depth from the ground surface (Fig. 28.4). Dugout ponds

involve more construction cost, therefore these are generally recommended when embankment type ponds are not economically feasible. The dugout ponds can also be recommended where maximum utilization of the harvested runoff water is possible for increasing the production of some important crops. This type of ponds require brick lining with cement plastering to ensure maximum storage by reducing the seepage loss.

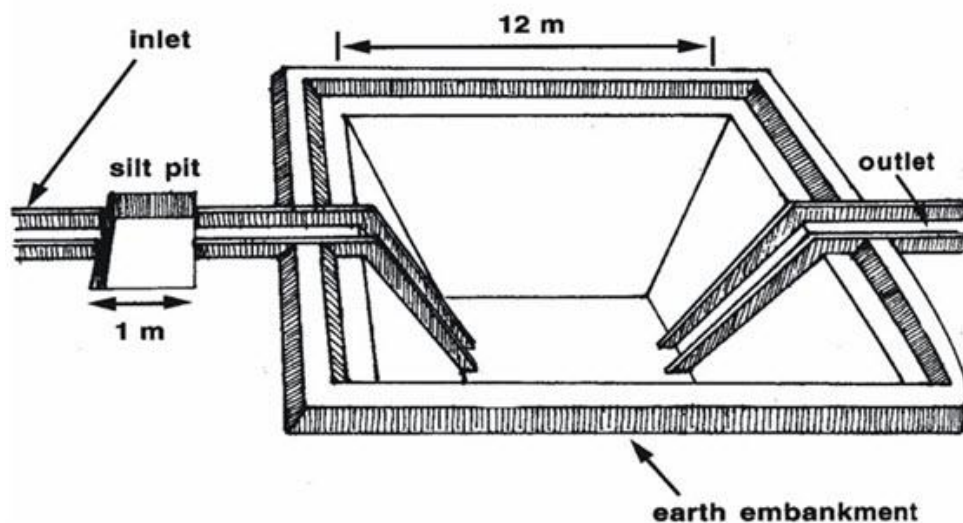

Fig. 28.4. Illustration of Dugout Pond. (Source: Barron and Salas, 2009)

Embankment Type Reservoir: These types of reservoirs are constructed by forming a dam or embankment on the valley or depression of the catchment area. The runoff water is collected into this reservoir and is used as per requirement. The storage capacity of the reservoir is determined on the basis of water requirement for various demands and available surface runoff from the catchment. In a situation when heavy uses of water are expected, then the storage capacity of the reservoir must be kept sufficient so that it can fulfill the demand for more than one year.

Embankment type reservoirs are again classified as given below according to the purpose for which they are meant.

Irrigation Dam: The irrigation dams are mainly meant to store the surface water for irrigating the crops. The capacity is decided based on the amount of input water available and output water desired. These dams have the provisions of gated pipe spillway for taking out the water from the reservoir. Spillway is located at the bottom of the dam leaving some minimum dead storage below it.

Silt Detention Dam: The basic purpose of silt detention dam is to detain the silt load coming along with the runoff water from the catchment area and simultaneously to harvest water. The silt laden water is stored in the depressed part of the catchment where the silt deposition takes place and comparatively silt free water is diverted for use. Such dams are located at the lower reaches of the catchment where water enters the valley and finally released into the streams. In this type of dam, provision of outlet is made for taking out the water for irrigation purposes. For better result a series of such dams can be constructed along the slope of the catchment.

High Level Pond: Such dams are located at the head of the valley to form the shape of a water tank or pond. The stored water in the pond is used to irrigate the area lying downstream. Usually, for better result a series of ponds can be constructed in such a way that the command area of the tank located upstream forms the catchment area for the

downstream tank. Thus all but the uppermost tanks are facilitated with the collection of runoff and excess irrigation water from the adjacent higher catchment area.

Farm Pond: Farm ponds are constructed for multi-purpose objectives, such as for irrigation, live-stock, water supply to the cattle feed, fish production etc. The pond should have adequate capacity to meet all the requirements. The location of farm pond should be such that all requirements are easily and conveniently met.

Water Harvesting Pond: The farm ponds can be considered as water harvesting ponds. They may be dugout or embankment type. Their capacity depends upon the size of catchment area. Runoff yield from the catchment is diverted into these ponds, where it is properly stored. Measures against seepage and evaporation losses from these ponds should also be.

Percolation Dam: These dams are generally constructed at the valley head, without the provision of checking the percolation loss. Thus, a large portion of the runoff is stored in the soil. The growing crops on downstream side of the dam, receive the percolated water for their growth.

28.3.2 Flood Water Harvesting

To harvest flood water, wide valleys are reshaped and formed into a series of broad level terraces and the flood water is allowed to enter into them. The flood water is spread on these terraces where some amount of it is absorbed by the soil which is used later on by the crops grown in the area. Therefore, it is often referred to as "Water Spreading" and sometimes "Spate Irrigation". The main characteristics of water spreading are:

- Turbulent channel flow is harvested either (a) by diversion or (b) by spreading within the channel bed/valley floor.
- Runoff is stored in soil profile.
- It has usually a long catchment (may be several km)
- The ratio between catchment to cultivated area lies above 10:1.
- It has provision for overflow of excess water.

The typical examples of flood water harvesting through water spreading are given below.

Permeable Rock Dams (for Crops)

These are long low rock dams across valleys slowing and spreading floodwater as well as healing gullies (Fig. 28.5). These are suitable for a situation where gently sloping valleys are likely to transform into gullies and better water spreading is required.

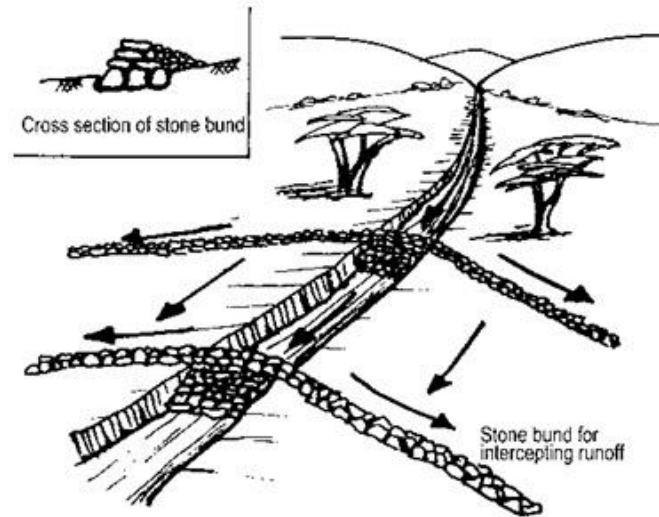

Fig. 28.5. Permeable Rock Dams. (Source: Barron and Salas, 2009)

Water Spreading Bunds (for Crops and Rangeland): In this method, runoff water is diverted to the area covered by graded bund by constructing diversion structures such as diversion drains. They lead to the basin through channels, where crops are irrigated by flooding. Earthen bunds are set at a gradient, with a "dogleg" shape and helps in spreading diverted floodwater (Fig. 28.6). These are constructed in arid areas where water is diverted from watercourse onto crop or fodder block.

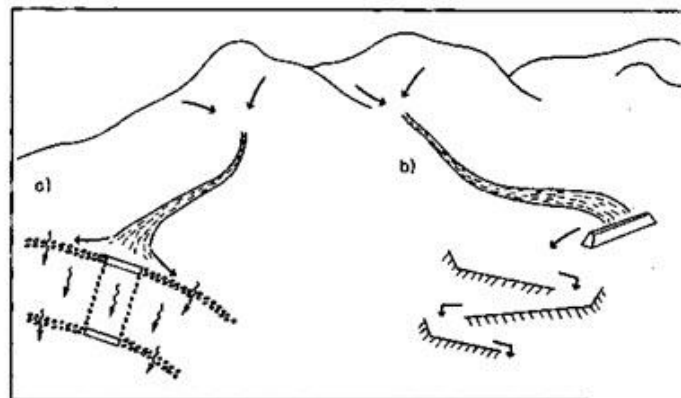

Fig. 28.6. Floodwater farming systems: (a) spreading within channel bed; (b) diversion system. (Source: Barron and Salas, 2009)

Flood Control Reservoir: The reservoirs constructed at suitable sites for controlling the flood are known as flood control reservoirs. They are well equipped with self-operating mechanical outlets for letting out the harvested water into the stream or canal below the reservoir as per requirement.

28.3.3 Groundwater Harvesting

Qanat System: A qanat consists of a long tunnel or conduit leading from a well dug at a reliable source of groundwater (the mother well). Often, the mother well is dug at the base of a hill or in the foothills of a mountain range. The tunnel leading from the mother well slopes gradually downward to communities in the valley below. Access shafts are dug intermittently along the horizontal conduit to allow for construction and maintenance of the qanat (Fig. 28.7). The Qanat system was used widely across Persia and the Middle East for

many reasons. First, the system requires no energy, relies on the force of gravity alone. Second, the system can carry water across long distances through subterranean chambers avoiding leakage, evaporation, or pollution. And lastly, the discharge is fixed by nature, producing only the amount of water that is distributed naturally from a spring or mountain, ensuring that the water table is not depleted. More importantly, it allows access to a reliable and plentiful source of water to those living in otherwise marginal landscapes (Fig. 28.8).

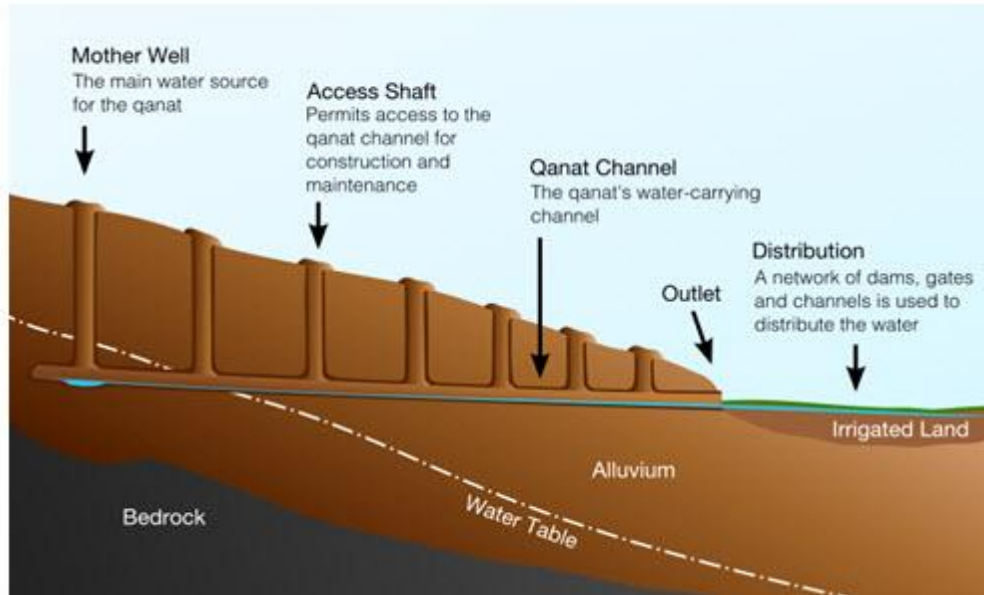

Fig. 28.7. Cross Section Showing Qanats. (Source: Barron and Salas, 2009)



Fig. 28.8. Ariel view of Qanats. (Source: www.visualphotos.com)

28.4 Runoff vs. Flood Water Harvesting

- Water harvesting techniques which harvest runoff from roofs or ground surfaces fall under the term rainwater harvesting while all systems which collect discharges from watercourses are grouped under the term flood water harvesting.
- Runoff harvesting increases water availability for on-site vegetation while flood waters harvesting provide a valuable source of water to local and downstream water users and play an important role in replenishing floodplains, rivers, wetlands and groundwater.

- Runoff harvesting reduces water flow velocity, as well as erosion rate and controls siltation problem while in flood water harvesting, floodwater enters into the fields through the inundation canals, carrying not only rich silt but also fish which can swim through the canals into the lakes and tanks to feed on the larva of mosquitoes.



AGRIMOON.COM

All About Agriculture...

Module 10: Water Quality and Pollution

Lesson 29 Water Pollution

Water pollution, whether in groundwater or surface water, is contamination or alteration of the physical, chemical or biological property of the water that causes the water to be harmful, detrimental or injurious to the public health, safety or welfare; or to the plant, animal or aquatic life dependent on the water or that impairs any designated beneficial use of the water.

29.1 Types of Water Pollution

Different types of water pollution can be listed as below.

1. Surface water pollution
2. Groundwater pollution
3. Microbial pollution
4. Oxygen depletion pollution
5. Nutrient pollution
6. Suspended matter pollution
7. Chemical pollution

1) Surface Water Pollution: Surface water pollution is the most visible form of pollution and can be seen floating on the water surface in lakes, streams, and oceans. Trash from human consumption, such as water bottles, plastics and other waste products, is most often evident on water surfaces. It also originates from oil spills and gasoline waste, which floats on the surface and affects the water and its inhabitants.

2) Groundwater Pollution: Groundwater pollution is becoming more and more relevant because it affects our drinking water obtained from the aquifers. Groundwater pollution is usually caused by highly toxic chemicals and pesticides that leak through the ground to contaminate the wells and aquifers below the surface.

3) Microbial Pollution: Microbiological pollution is the natural form of water pollution that is caused by microorganisms in uncured water. Most of these organisms are harmless but some bacteria, viruses, and protozoa can cause serious diseases such as cholera, typhoid, etc. This is a significant problem in third world or developing countries where many people have no clean drinking water and/or facilities to purify the water.

4) Oxygen Depletion Pollution: Microorganisms that thrive in water feed on biodegradable substances. When there is an influx of biodegradable material from sources such as waste or erosion from farming, the numbers of these microorganisms increase and utilize the usable oxygen. When the oxygen level is depleted, beneficial aerobic microorganisms die and anaerobic microorganisms thrive. Some of these organisms produce damaging toxins like sulfide and ammonia.

5) Nutrient Pollution: Nutrients are usually found in wastewater and fertilizers. Excess concentration of nutrients in water bodies can cause increased vegetation in the water bodies such as algae and weeds, using up the oxygen in the water and affecting the surrounding marine life and other organisms in the water.

6) Suspended Matter Pollution: It occurs when pollutants enter the water and do not mix with the water molecules. These suspended particles form fine silt on the waterbed, harming the marine life by taking away the nutrients, restricting oxygen diffusion into the water body and disturbing their habitat.

7) Chemical Pollution: From industrial plants and farms, chemical runoff flows into the nearby rivers and water sources. Metals and solvents flow out of factories into the water, polluting the water and affecting wildlife. Pesticides from farms also endanger the aquatic life. These dangerous pesticides and toxins can get transferred through infected fish and affects human health. Petroleum is also a type of chemical pollutant that dramatically affects the aquatic life.

29.2 Sources of Water Pollution

Based on the sources, water pollution is broadly divided into two groups (Fig. 29.1):

1. Point Sources Pollution
2. Non-Point Sources Pollution

1) Point Sources Pollution: Contamination that enters a waterway from a single, identifiable source, traced to a specific source is considered as point source pollution of water. Point source pollution comes directly from a known source like an industrial or sewage outfall pipe. Point sources are typically associated with manufacturing processes. Point source contamination includes leaking chemical tanks, effluents coming from a waste treatment of industrial plant, manure spill from a hog confinement lagoon, discharge from a sewage treatment plant, factory, city storm drain, industrial storm water, discharge from construction sites, leakage of oil tankers in the sea, septic tank systems, storage lagoons for polluted waste, municipal landfills, underground storage tanks containing pollutants such as gasoline, public and industrial wastewater treatment plants etc.

2) Non-point Sources Pollution: Contamination that does not originate from a single discrete source is called non-point source pollution. It is the cumulative effect of small amounts of contaminants gathered from wide spread area. They can't be tracked to a single point or source. They come from many miscellaneous or diffuse sources rather than from an identifiable, specific point. It includes soil erosion, chemical runoff, animal waste pollution, leaching out of fertilizers from agricultural lands and nutrient runoff in storm water from agricultural field and forest. It also includes contaminated storm water washed off from parking lots, roads and highways, also called urban runoff. Other significant sources of non-point source pollution include litter; disposal of wastes in catch basins; hazardous waste improperly stored or discarded; improperly operating septic systems; erosion from construction sites, farms or home sites; acid deposition including acid rain and fog; pollution from roadways and road salting activities; leaking sewer lines; storm-water runoff from city and suburban streets (oil gasoline, dog faeces, litter); pesticides and fertilizers from croplands; and salt on roads for snow and ice control.

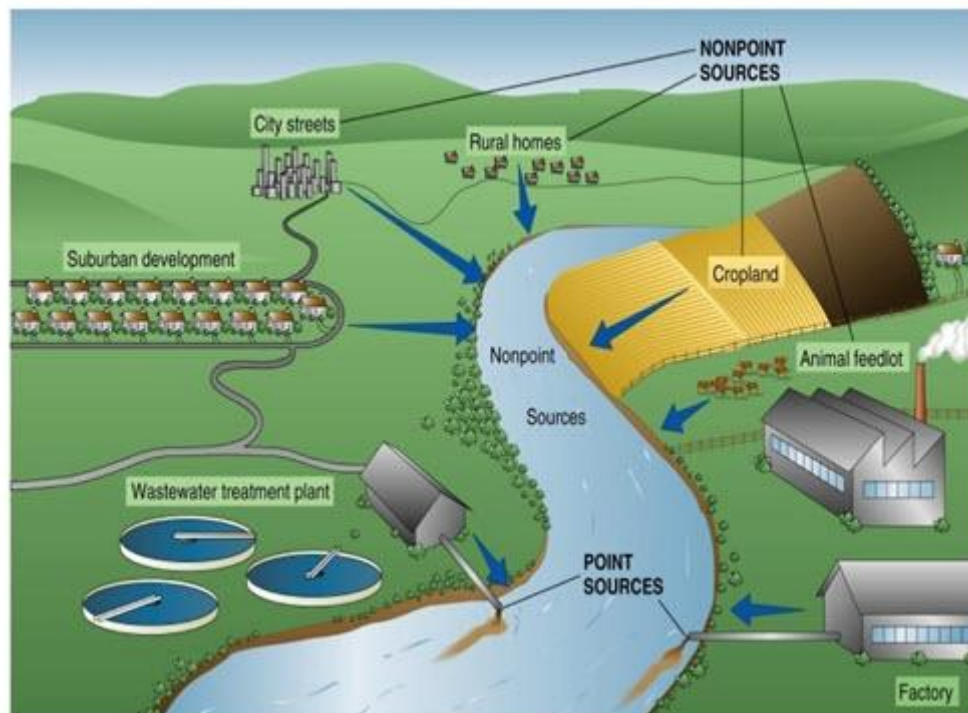

Fig. 29.1. Point and Non-Point Source Pollution. (Source : Calhoun, 2009)

29.3 Effects of Water Pollution

Physio-Chemical Effects: A large number of pollutants can impart colour, tastes and odors to the receiving waters thus, making them unaesthetic and even unfit for domestic consumption. The changes in oxygen, temperature and pH affect the chemistry of waters resulting in the formation of unwanted products. The addition of organic matter results in depletion of oxygen. The direct addition of nutrients through various sources enhances the algal and other biological growths which when die and decompose, further deplete the oxygen. The decomposition of excessive organic matter when undergoes in absence of oxygen results in odorous and unaesthetic conditions due to accumulation of several obnoxious gases like ammonia, hydrogen sulphide and methane etc.

Biological Effects: The addition of pollutants leads to the shift in flora and fauna due to homeostatic (self-regulating) factors operating in the aquatic systems. Most freshwater algae are highly sensitive to pollutants and their elimination modifies the prey-predatory relationships by breaking down the food chains. This results in change of the whole plant and animal communities. The diversity of organisms increases due to encouragement of the growth of only a few tolerant forms in the polluted conditions.

Toxic Effects: These are caused by pollutants such as heavy metals, biocides, cyanide and other organic and inorganic compounds having detrimental effects on organisms. These substances have usually very low permissible limits in waters and their presence beyond these limits can render the water unfit for aquatic biota and even for human use.

Pathogenic Effects: In addition to the chemical substances, polluted water has several pathogenic, nonpathogenic microorganisms and viruses. The clostridium, perfringens, staphylococcus, shigella cause various types of food poisoning. Apart from this, many waterborne diseases like cholera, typhoid, paratyphoid, colitis and infective hepatitis (jaundice) are spread by consumption of sewage contaminated waters.

There could be big list of pollutants and their specific effects. A few of the effects of specific pollutants present in water are summarized in Table 29.1.

Table 29.1. Effects of Specific Pollutants Present in Water

Pollutants	Effects
Zinc (Zn)	It is an important cell component in several metalloenzymes. Heavy doses of Zinc salt (165 mg/l) for consecutive 26 days cause vomiting, renal damage, cramps, etc.
Copper (Cu)	Excess of Cu in human body (more than 470 mg) is toxic, may cause hypertension, sporadic fever, uremia and coma. Copper also produces pathological changes in brain tissue.
Barium (Ba)	Excess of Ba (more than 100 mg) in human body may cause excessive salivation, colic, vomiting, diarrhoea, tremors, paralysis of muscles or nervous system, damage to heart and blood vessels.
Iron (Fe)	It is a component of blood cells and lival metaloenzymes. However, more than 10 mg per kg of body weight causes rapid respiration and pulse rates, congestion of blood vessels, hypertension and drowsiness. It increases hazard of pathogenic organisms, as many of them require Fe for their growth.
Cadmium (Cd)	50 mg may cause vomiting, diarrhoea, abdominal pains, loss of consciousness. It takes 5–10 years for chronic Cd intoxication. During first phase, discolouration of teeth, loss of sense of smell and mouth dryness occurs. Afterwards it may cause decrease of red blood cells, impairment of bone marrow, lumber pains, disturbance in calcium metabolism, softening of bones, fractures, skeletal deformations, damage of kidney, hypertension, tumor formation, heart disease, impaired reproductive function, genetic mutation, etc.
Mercury (Hg)	Excess mercury in human body (more than 100 mg) may cause headache, abdominal pain, diarrhoea, destruction of haemoglobin, tremors, very bad effects on cerebral functions and central nervous system, paralysis, damage of renal tissues, hyper coagulability of blood, mimamata disease, inactivates functional proteins and even causes death. It may cause impairment of vision and muscles and even coma. It disturbs reproductive and endocrine system. It also causes insomnia, memory loss, gum inflammation, loosening of teeth, loss of appetite, etc.
Lead (Pb)	More than 400 mg of lead in human body can cause brain damage, vomiting, loss of appetite, convulsions, uncoordinated body movements, helplessly

	amazed state, and coma. It is retained in liver, kidney, brain, muscle, soft tissues, and bones. It leads to high rate of miscarriages, affects skin, and respiratory system, damages kidney, liver and brain cells. It also disturbs endocrine system, causes anaemia, and long term exposure may cause even death.
Arsenic (As)	It is poisonous to fishes, animals and humans. More than 25 mg of arsenic in human body causes vomiting, diarrhoea, nausea, irritation of nose and throat, abdominal pain, skin eruptions inflammations and even death. It binds globulin of blood haemoglobin in erythrocytes. It may cause cancer of skin, lungs and liver, chromosomal aberration and damage, gangrene, loss of hearing, injury to nerve tissue, liver and kidney damage. Minor symptoms of As poisoning, are weight loss, hair loss, nausea, depression, fatigue, white lines across toe nails and finger nails.
Vanadium (V)	It is very toxic, may cause paralysis.
Silver (Ag)	It causes pathological change in kidney, liver and may even damage kidney. and may cause Argyria (discolouration of skin). It affects mucous membranes and eyes. In high doses, it may be fatal to humans.
Radioactive materials/ metals/ substances	These generally cause 'Gene' mutation, ionization of body fluids, chromosomal mutations and cancers. It destroys body cell tissue, and adversely affects reproductive system. If the mother is exposed to radiation during pregnancy, it causes severe mental retardation and leukaemia in infants. Radioactive metals like heavy metals are nephrotoxic and damage kidneys.
Fluoride	Excess fluoride intake in body results in progressive crippling scourge (sponging)/fluorosis of bones, and teeth. It may cause metabolic alternations in soft tissues and their functional mechanism.
Selenium (Se)	Signs of Se poisoning (more than 4 mg) are fever, nervousness, vomiting and low blood pressure. It causes damage to liver, kidney and spleen, loss of nails and hair and blindness to animals. It affects enzyme systems and interferes with sulphur metabolism. It can cause growth inhibition, skin discolouration, bad teeth, psychological problem, and gastro intestinal problems, but trace amount of Se is protective against poisoning by Hg, Cd, and Ag.
Chromium (Cr)	Any chromium compound is toxic but hexavalent Cr greater than 70 mg is very toxic. It causes cancer, anuria, nephritis, gastrointestinal ulceration, and perforation in partition of nose. It penetrates cell membrane and badly affects the central nervous system. It causes respiratory trouble and lung

	tumors when inhaled. It may cause complications during pregnancy. and has an adverse effect on aquatic life. Trace amount of CrIII is essential for normal glucose, protein and fat metabolism and hence it is an essential trace element in diet.
Manganese (Mn)	Mn is essential for mammals but in concentration greater than 100 ppm, is toxic and causes growth retardation, fever, sexual impotence, muscles fatigue, and eye blindness.
Cobalt (Co)	High dose (27 mg or above) can cause paralysis, diarrhoea, low blood pressure, lung irritation and bone defects.
Nickel (Ni)	More than 30 mg may cause changes in muscle, brain, lungs, liver and kidneys and can also cause cancer, tremor, paralysis and even death.
Boron (B)	Boron in traces is essential for plant growth. In higher concentration it is harmful to crops and affects metabolic activities of plants. It also affects central nervous system.
Alkalinity and Acidity	Permissible range of pH value if violated may cause health problems to human and animals and loss of productivity in agriculture.
Phosphate and nitrates	Phosphates and nitrates are soil nutrients and not toxic in low concentration. They deplete oxygen by promoting excess algae production in water and - giving bad odour and taste of water which are detrimental to aquatic life. They are toxic for human and animal life if concentration is beyond the permissible limits. Nitrates also cause cyanosis or blue body disease.
Chlorine (Cl)	It destroys plant and aquatic life and is a biocide.
Sulphide	It gives bad odour, toxic to many aquatic organisms and animals.
Salinity	Salinity is very harmful for soils as it destroys agricultural land.
Oil/Grease/ Oil Sludge	Petroleum products in general are very harmful for soils, aquatic life, animal, human and plant life. They are very toxic. Agricultural land may suffer accumulation of oily waste affecting aeration and fertility. Many constituents of oily sludge are even carcinogenic and potent immunotoxicants.
Surfactants	They are toxic and harmful for aquatic life, animals and humans. They

and detergents	inhibit self-purification of water.
Phenols	They are toxic and impart objectionable odour. They generally subdue plant growth. Some phenols (nitrophenyl etc) are carcinogens.
Cyanides	Cyanide poses a serious health hazard. Apart from acute toxicity and chronic toxicity, it leads to development of iodine deficiency disorders.
Pesticides/ Insecticides	They are highly poisonous for humans and animals. Also they lower seed germination, play a role in the development of Parkinson's disease, destruction of nerve cells in certain regions of brain resulting in loss of dopamine which is used by nerve cells to communicate with brain. Some of these are physical poisons, some are protoplasmic poisons causing liver damage, some are respiratory poisons and some are nerve poisons.
Aluminium (Al)	It is especially toxic for brain and sometimes may lead to Alzheimer's disease in humans.



AGRIMOON.COM

All About Agriculture...

Lesson 30 Water Quality

Clean, safe and adequate freshwater is vital to the survival of all living organisms and the smooth functioning of ecosystems, communities, and economies. But the quality of the world's water is increasingly threatened as human populations grow, industrial and agricultural activities expand, and as climate change threatens major alterations of the hydrologic cycle. Quantity of usable water on the earth is extremely small and pollution will further reduce the available supply.

Every day, millions of tons of inadequately treated sewage, industrial and agricultural wastes are poured into the water bodies leading to pollution. More people die from the consequences of unsafe water than from all forms of violence, including war. Water contamination of natural ecosystems affects humans directly by destroying fisheries or causing other impacts on biodiversity that affect food production. Most polluted freshwater ends up in the oceans, causing serious damage to many coastal areas, fisheries and worsening the ocean and coastal resources.

30.1 Importance of Water Quality

A wide range of human and natural processes affect the biological, chemical and physical characteristics of water and thus impact water quality. It includes contamination by pathogenic organisms, trace metals, toxic chemicals, introduction of non-native species etc. Changes in the acidity, temperature and salinity of water harm aquatic ecosystems and make water unsuitable for human use. Numerous human activities which include agriculture, industry, mining, disposal of human waste, population growth, urbanization, climate change etc impact water quality. Water contamination weakens or destroys natural ecosystems that support human health, food production, and biodiversity.

Poor water quality threatens the health of people and ecosystems, reduces the availability of safe water for drinking and other uses and limits economic productivity and development opportunities. There is an urgent need for protecting and improving the quality of water. It can be achieved by preventing future water pollution, treating waters that are already contaminated and restoring the quality and health of rivers, lakes, aquifers, wetlands and estuaries.

In India, agencies like the Indian council of Medical Research (ICMR), Bureau of Indian Standards and Ministry of Works and Housing have formulated certain drinking water standards which are being followed by different authorities. World Health Organization (WHO) has also laid down drinking water standards which are considered as international standards.

30.2 Standards of Water Quality for Different Uses

For any water body to function adequately in satisfying the desired use, it must have the corresponding degree of purity. Drinking water should be of the highest purity. As the magnitude of demand for water is fast approaching the available supply, the concept of management of the quality of water is becoming as important as its quantity. Each water use has specific quality need. Therefore, to set the standard for the desired quality of a water body, it is essential to identify the uses of water in that water body.

- Drinking Water Standards
- Irrigation Water Standards
- Stream Water Standards
- **Drinking Water Standards:** Drinking water is the water intended for human consumption for drinking and cooking purposes from any source. It includes water supplied by pipes or any other means for human consumption by any supplier.
- **Irrigation Water Standards:** For the quality of water for irrigation the major parameters of concern are salinity denoted by dissolved solids and conductivity, potentially toxic trace elements, and herbicides. In addition, the presence of sodium is also an important parameter excess quantities of which can deteriorate the soils. High value of sodium may also damage the sensitive crops because of sodium phytotoxicity. The sodium in waters can be denoted by percent sodium and "sodium absorption ratio" (SAR).
- **Stream Standards:** Water quality objectives for freshwaters take into account several major uses of water like irrigation, drinking, industry, power generation, recreation etc. All water bodies or stretches are not necessarily required to meet all potential uses. This has led to the concept of classification and zoning of water bodies which indicate that their quality has to meet the requirement of one or more potential uses. For each typical use, water quality criterion should take into account the special constraints on water quality imposed by that use. Based on this, any water body or its stretch can be designated for some particular best use which can be termed as the designated best use. The water resources can be classified or zoned depending upon the designated best use of the water.

In India, the Central Pollution Control Board (CPCB) has developed a concept of designated best use of water. According to this, out of the several uses of water of a particular body, the use which demands the highest quality is termed its designated best use. Five designated best uses have been identified. This classification helps the water quality managers and planners to set water quality targets and design suitable restoration programs for various water bodies (Table 30.1).

Table 30.1. Designated Best Uses of Water (Source IS 2296:1992)

Designated best use	Class	Criteria
Drinking Water Source without conventional treatment but after disinfection	A	1. Total Coliforms Organism MPN/100 ml shall be 50 or less 2. pH between 6.5 and 8.5 3. Dissolved Oxygen 6 mg/l or more 4. Biochemical Oxygen Demand (5 days) at 20 °C, 2 mg/l or less
Outdoor bathing (Organised)	B	1. Total Coliforms Organism MPN/100 ml shall be 500 or less

		2. pH between 6.5 and 8.5 3. Dissolved Oxygen 5 mg/l or more 4. Biochemical Oxygen Demand (5 days) at 20 °C, 3 mg/l or less
Drinking water source after conventional treatment and disinfection	C	1. Total Coliforms Organism MPN/100 ml shall be 5000 or less 2. pH between 6 and 9 3. Dissolved Oxygen 4 mg/l or more 4. Biochemical Oxygen Demand (5 days) at 20 °C, 3 mg/l or less
Propagation of Wild life and Fisheries	D	1. pH between 6.5 and 8.5 2. Dissolved Oxygen 4 mg/l or more 3. Free Ammonia (as N) 4. Biochemical Oxygen Demand (5 days) at 20 °C, 2 mg/l or less
Irrigation, Industrial Cooling, Controlled Waste disposal	E	1. pH between 6.0 and 8.5 2. Maximum electrical conductivity at 25 °C should be 2250 micro mhos/cm 3. Sodium absorption Ratio Max. 26 4. Boron Max. 2 mg/l

In India, CPCB has identified water quality requirements in terms of a few chemical characteristics, known as primary water quality criteria. Further, Bureau of Indian Standards has also recommended water quality parameters for different uses in the standard- IS 2296:1992 (Table 30.2).

Table 30.2. Water Quality Standards in India. (Source: IS 2296:1992)

Characteristics	Designated best use				
	A	B	C	D	E

Dissolved Oxygen (DO) mg/l, min	6	5	4	4	-
Biochemical Oxygen demand (BOD) mg/l, max	2	3	3	-	-
Total coliform organisms MPN/100 ml, max	50	500	5,000	-	-
pH value	6.5-8.5	6.5-8.5	6.0-9.0	6.5-8.5	6.0-8.5
Colour, Hazen units, max.	10	300	300	-	-
Odour	Un-objectionable			-	-
Taste	Tasteless	-	-	-	-
Total dissolved solids, mg/l, max.	500	-	1,500	-	2,100
Total hardness (as CaCO ₃), mg/l, max.	200	-	-	-	-
Calcium hardness (as CaCO ₃), mg/l, max.	200	-	-	-	-
Magnesium hardness (as CaCO ₃), mg/l, max.	200	-	-	-	-
Copper (as Cu), mg/l, max.	1.5	-	1.5	-	-
Iron (as Fe), mg/l, max.	0.3	-	0.5	-	-
Manganese (as Mn), mg/l, max.	0.5	-	-	-	-
Chlorides (as Cl), mg/l, max.	250	-	600	-	600
Sulphates (as SO ₄), mg/l, max.	400	-	400	-	1,000
Nitrates (as NO ₃), mg/l, max.	20	-	50	-	-
Fluorides (as F), mg/l, max.	1.5	1.5	1.5	-	-

Phenolic compounds (as C ₂ H ₅ OH), mg/l, max.	0.002	0.005	0.005	-	-
Mercury (as Hg), mg/l, max.	0.001	-	-	-	-
Cadmium (as Cd), mg/l, max.	0.01	-	0.01	-	-
Selenium (as Se), mg/l, max.	0.01	-	0.05	-	-
Arsenic (as As), mg/l, max.	0.05	0.2	0.2	-	-
Cyanide (as Pb), mg/l, max.	0.05	0.05	0.05	-	-
Lead (as Pb), mg/l, max.	0.1	-	0.1	-	-
Zinc (as Zn), mg/l, max.	15	-	15	-	-
Chromium (as Cr ⁶⁺), mg/l, max.	0.05	-	0.05	-	-
Anionic detergents (as MBAS), mg/l, max.	0.2	1	1	-	-
Barium (as Ba), mg/l, max.	1	-	-	-	-
Free Ammonia (as N), mg/l, max	-	-	-	1.2	-
Electrical conductivity, micromhos/cm, max	-	-	-	-	2,250
Sodium absorption ratio, max	-	-	-	-	26
Boron, mg/l, max	-	-	-	-	2

30.3 National Water Quality Monitoring Programme

Effective monitoring of water quality can influence containment of pollution through better understanding of the problem and devising appropriate solutions for better management. In India, water quality monitoring is being carried out historically for a number of reasons. Following different organizations have been and are currently operating to satisfy their own particular objectives:

- Central & State Pollution Control Boards (CPCB, SPCBs)
- Central Water Commission & State Surface Water departments (CWC, SSWD)

- Central Ground Water Board & State Ground Water Departments (CGWB, SGWD)
- National River Conservation Directorate (NRCD)
- Research Institutions e.g. National Environmental Engineering Research Institute, Nagpur (NEERI)
- Others Academic Institutions, State Public Health and Environmental

Departments (PHED), Water Supply and Sewerage Boards (WSSB).

Objectives: The preamble of Water (prevention and control of pollution) Act, 1974 stated that pollution control board, both at States and Central levels, are meant to restore and maintain the wholesomeness of water bodies in India. Water quality monitoring is therefore an imperative prerequisite in order to assess the extent of maintenance and restoration of water bodies. The water quality monitoring is performed with following main objectives:

- Rational planning of pollution control strategies and their prioritization,
- To assess the nature and extent of pollution control needed in different water bodies or their part,
- To evaluate the effectiveness of pollution control measures already in existence,
- To evaluate the water quality trend over a period of time,
- To assess the assimilative capacity of a water body thereby reducing cost on pollution control,
- To understand the environmental fate of different pollutants and
- To assess the fitness of water for different uses.

Monitoring Network: The Central Pollution Control Board (CPCB) has established a network of monitoring stations on rivers across the country (Table 30.3). The present network comprises 1700 stations in 27 States and 6 Union Territories spread over the country. The monitoring network covers 353 Rivers, 107 Lakes, 9 Tanks, 44 Ponds, 15 Creeks/Seawater, 14 Canals, 18 Drains and 490 Wells. Among the 1700 stations, 980 are on rivers, 117 on lakes, 18 on drains, 27 on canals, 9 on tank, 15 on creeks/seawater, 44 on pond and 490 are groundwater stations. Presently the inland water quality-monitoring network is operated under a three-tier programme i.e. Global Environmental Monitoring System (GEMS), Monitoring of Indian National Aquatic Resources System (MINARS), and Yamuna Action Plan (YAP). Water samples are being analyzed for 28 parameters consisting of physico-chemical and bacteriological parameters for ambient water samples apart from the field observations. Besides this, 9 trace metals and 28 pesticides from selected samples are analyzed. Bio monitoring is also carried out on specific locations. In view of limited resources, limited numbers of organic pollution related parameters are chosen for frequent monitoring i.e. monthly or quarterly and major cations, anions, other inorganic ions and micro pollutants (Toxic Metals & POP's) are analyzed once in a year to keep a track of water quality over a long period of time. The water quality data are reported in Water Quality Status Year Book.

Table 30.3. Statewise Water Quality Monitoring Stations. (River, Lake, Tank, Pond, Canal, Creek/Sea water, Drain and Well)

State	Total No.
Andhra Pradesh	96
Assam	101
Bihar	86
Chandigarh	11
Chhattisgarh	27
Daman, Diu, Dadra And Nagar Haveli	24
Delhi	15
Goa	29
Gujarat	113
Haryana	23
Himachal Pradesh	104
Jammu & Kashmir	9
Jharkhand	36
Karnataka	45
Kerala	110
Lakshadweep	16

Madhya Pradesh	105
Maharashtra	196
Manipur	20
Meghalaya	13
Mizoram	6
Nagaland	8
Orissa	93
Pondicherry	22
Punjab	43
Rajasthan	51
Sikkim	14
Tamil Nadu	32
Tripura	13
Uttar Pradesh	111
Uttaranchal	29
West Bengal	99
Total	1700

Parameters Observed: The water samples are analysed for 9 core parameters and 19 general parameters. The monitoring agencies also analyze the trace metals at few locations. The list of parameters being identified under the National Water Quality Monitoring Programme is presented in Table 30.4.

Table 30.4. List of parameters monitored under National Water Quality Monitoring Programme

Core Parameters (9)	Field Observations (7)
PH	Weather
Temperature	Depth of main stream/ depth of water table
Conductivity, $\mu\text{mhos/cm}$	Colour and intensity
Dissolved Oxygen, mg/l	Odour
BOD, mg/l	Visible effluent discharge
Nitrate - N , mg/l	Human activities around station
Nitrite - N, mg/l	Station detail
Faecal Coliform, MPN/100 ml	Trace Metals (9)
Total Coliform, MPN/100 ml	Arsenic, $\mu\text{g/l}$
General Parameters (19)	Cadmium, $\mu\text{g/l}$
Turbidity, NTU	Copper, $\mu\text{g/l}$
Phenolphthalein Alkalinity, CaCO_3	Lead, $\mu\text{g/l}$
Total Alkalinity, as CaCO_3	Chromium (Total) , $\mu\text{g/l}$
Chlorides, mg/l	Nickel, $\mu\text{g/l}$
COD, mg/l	Zinc, $\mu\text{g/l}$
Total Kjeldahl - N, as N mg/l	Mercury, $\mu\text{g/l}$

Ammonia - N, as N mg/l	Iron (Total) , $\mu\text{g/l}$
Hardness, as CaCO_3	Pesticides (15)
Calcium, as CaCO_3	Alpha BHC, $\mu\text{g/l}$
Sulphate, mg/l	Beta BHC, $\mu\text{g/l}$
Sodium, mg/l	Gama BHC (Lindane) , $\mu\text{g/l}$
Total Dissolved Solids, mg/l	O P DDT, $\mu\text{g/l}$
Total Fixed Dissolved Solids, mg/l	P P DDT, $\mu\text{g/l}$
Total suspended Solid, mg/l	Alpha Endosulphan, $\mu\text{g/l}$
Phosphate, mg/l	Beta Endosulphan, $\mu\text{g/l}$
Boron, mg/l	Aldrin, $\mu\text{g/l}$
Magnesium, as CaCO_3	Dieldrin, $\mu\text{g/l}$
Potassium, mg/l	Carboryl(Carbamate) , $\mu\text{g/l}$
Fluoride, mg/l	2-4 D, $\mu\text{g/l}$
Bio-Monitoring (3)	Malathian, $\mu\text{g/l}$
Saprobity Index	Methyl Parathian, $\mu\text{g/l}$
Diversity Index	Anilophos, $\mu\text{g/l}$
P/R Ratio	Chloropyriphos, $\mu\text{g/l}$

Frequency of Monitoring: Out of the total monitoring stations of 1700, 32% stations monitor on monthly basis, 28.82 % on half yearly basis and 38.64% on a quarterly basis.

River Basin Wise Distribution of Water Quality Monitoring Stations: The numbers fresh water quality monitoring stations on each river (Table 30.5), its tributary, sub tributary, lake, ponds, tanks, canals, creeks and on groundwater reveal that:

- 764 stations i.e. 44.94% are located in major River basins. Out of them river Ganga dominates with nearly 30.49% of the stations of major river basin.
- Medium rivers have 216 stations i.e. 12.70% of the total stations, whereas; 107 lakes, 9 tanks and 44 ponds have 170 stations which are nearly 10% of the total stations.
- Creeks, canals, and drains have only 60 stations.
- Next to major river basin, the major numbers of monitoring stations are for ground water and with a number of 490 stations accounts for 28.82% of the total stations.

Table 30.5. River Basinwise Distribution of Water Quality Monitoring Stations (2009)

River (main stream)	Total stations
Baitarani (5)	6
Brahmani (16)	25
Brahmaputra (10)	68
Cauvery (20)	36
Ganga (52)	233
Godavari (35)	83
Indus	72
Krishna (22)	93
Mahi (9)	15
Mahanadi (22)	48
Narmada (21)	25

Pennar (5)	5
Sabarmati (9)	12
Subarnarekha (12)	13
Tapi (14)	30
Medium rivers	216
Lakes (117)	170
Tanks (9)	
Ponds (44)	
Creeks, Canals and Drains	60
Groundwater	490
Total	1700



Module 11: Watershed Modeling

Lesson 31 Modeling of Watershed Processes

Global advances in economies and standards of living have resulted in a growing dependency on water resources. Many societies have experienced water scarcity as a result of current patterns with societal advances; these are associated with factors such as population growth, increased urbanization and industrialization, increased energy use, increased irrigation associated with advances in agriculture productivity, desertification, global warming and poor water quality. Improved understanding of how each of these factors influences water supply, demand and quality require improved abilities to understand the underlying processes and their impact on water availability and use. This entails employing a holistic approach which integrates hydrologic processes at the watershed scale to determine an overall watershed response to both user demands and changing climates.

31.1 Model, Watershed Model and Modeling

Watershed modeling is being utilized as a tool to better understand surface and subsurface water movement and the interactions between these water bodies. Models are the simple representations of complicated systems or processes. Some of the oldest forms of models were actual miniature physical representations of natural complicated systems. More importantly, they offer tools to guide decision making on water resources, water quality and related hazard issues. Mathematical models are also representations of systems, but use a series of mathematical equations. The number, form and interconnections of these equations in a model can range from very simple to highly sophisticated.

31.1.1 Watershed Modeling

Watershed models simulate natural processes of the flow of water, sediment, chemicals, nutrients, and microbial organisms within watersheds, as well as quantify the impact of human activities on these processes. Simulation of these processes plays a fundamental role in addressing a range of water resources, environmental and social problems. The current generation of watershed models is quite diverse and varies significantly in sophistication and data and computational requirements. Newly emerging technologies (Geographical Information System, GIS; and Remote Sensing, RS) are being increasingly integrated into watershed models.

31.1.2 Why Modeling?

Modeling is useful for many purposes, but it may not always be the best tool for a given situation. The ability of models to predict future conditions is very useful for projecting the outcome(s) of various possible management measures and strategies. Modeling is thus a tool to aid in selecting the desired management options. Model may help to predict the outcomes of water allocation alternatives, watershed managements, resource management, ecological restoration etc. Two points to be considered while the models are discussed are:

1. Models are a type of tool and are used in combination with many other assessment techniques.
2. Models are a reflection of our understanding of watershed systems. As with any tool, the answers they give are dependent on how we apply them, and the quality of these answers is no better than the quality of our understanding of the system.

31.2 Watershed Modeling-State of Art

The state-of the-art watershed-scale models and modeling systems include the use of artificial intelligence (AI) for processing of information to improve modeling speed and accuracy, the impact of data resolution and watershed scale on the modeling process. Genetic algorithms (GAs), artificial neural networks (ANN) and fuzzy logic (FL) are currently being employed to assist in processing data, develop improved relationships between hydrologic processes and in some cases, assist in filling voids in the measured data. In addition, tools have evolved to have enhanced modeling capabilities. Two of these tools are Geographic Information Systems (GIS) and Remote Sensing (RS) technologies. Integration of these tools into watershed modeling has improved the spatial and temporal components of watershed models, specifically by reducing model prediction uncertainty due to input data, initial conditions and even parameterization. Advancements in computational efficiencies have also contributed to the increased inclusion of uncertainty analysis in modeling procedures. Uncertainty analysis, which refers to the evaluation of the difference between an observed or calculated value and the true value, generally relies on completing thousands of model simulations using probability distributions to represent model factors (such as inputs or parameters). Advancements in computational efficiency have increased the feasibility of simulating these large datasets and post-processing the output, as is evident by the growing number of researches in this area. Along with the technological advances, the science of watershed modeling has evolved with regard to the calibration and validation process. The most historically common component included in hydrologic calibration-validation is the comparison of predicted and measured downstream flows. With increasing frequency, a more comprehensive flow calibration-validation is presented in modeling applications that include base flow, surface runoff flow and total flow. The inclusion of multiple variables in the calibration process has also led to further development of global sensitivity analyses and automated multi-objective calibration methods. The interest in predicting and calibrating multiple outputs from a watershed model leads to the identification of a multi-objective function for watershed modeling applications. Multi objective functions provide optimization criteria for multiple modeling objectives in a mathematical form. Identification of a multi-objective function is essential for calibrating watersheds with multiple outputs of interest to ensure that all components receive appropriate consideration and there are minimal to no biases among the variables of interest.

31.3 Benefits of Watershed Modeling

The ability to deliver reliable water resources to a growing population and effectively forecast flooding, drought and surface/groundwater water contamination represent increasingly difficult and interrelated challenges to water resource managers, engineers and researchers. Such challenges necessitate the employment of a more holistic approach that is capable of examining individual processes and systems and the interface between them. The watershed modeling includes an observed shift to a more holistic, watershed-based focus of the regulatory community, various types of watershed-scale models and watershed modeling systems available today, use of artificial intelligence in modeling processes, and

issues faced through scale-up of hydrologic processes and data resolution. The benefits of using these techniques include the ability to assist water resource and watershed managers with a variety of applications such as evaluating and developing TMDLs (Total Maximum Daily Load). Watershed-scale models thus can be employed by water resource managers and decision makers as a screening tool to identify the best management option/strategy for allocating sufficient water for different purposes with reduced problems under the series of possibilities.

31.4 Watershed Models

Watershed models can be grouped into various categories based upon the modeling approaches used. The primary features for distinguishing watershed-scale modeling approaches include the nature of the employed algorithms (empirical, conceptual or physically-based), whether a stochastic or deterministic approach is used for model input or parameter specification and whether the spatial representation is lumped or distributed. The watershed models can be grouped or classified based on different criteria as given below.

1. Based on Nature of Input and Uncertainty

Watershed models can be categorized as *deterministic* or *stochastic* depending on the techniques involved in the modeling process. *Deterministic models* are mathematical models in which the outcomes are obtained through known relationships among states and events, e.g. Precipitation-Runoff Modeling System (PRMS). *Stochastic models* will have most, if not all, of their inputs or parameters represented by statistical distributions which determine a range of outputs, e.g. Weather Generators.

2. Based on Nature of the Algorithms

Physically-based models are based on the understanding of the physics associated with the hydrological processes which control catchment response and utilize physically based equations to describe these processes, e.g. Soil and Water Assessment Tool (SWAT); MIKE SHE. *Empirical models* consist of functions used to approximate or fit available data. Such models span a range of complexity, from simple regression models to hydro informatics-based models which utilize Artificial Neural Networks (ANNs), Fuzzy Logic, Genetic and other algorithms.

3. Based on Nature of Spatial Representation

Watershed-scale models can further be categorized on a spatial basis as *lumped*, *semi-distributed* or *distributed models*. The *lumped modeling* approach considers a watershed as a single unit for computations where the watershed parameters and variables are averaged over this unit. Compared to lumped models, semi-distributed and distributed models account for the spatial variability of hydrologic processes, input, boundary conditions and watershed characteristics. For *semi-distributed models*, the aforementioned quantities are partially allowed to vary in space by dividing the basin into a number of smaller sub-basins which in turn are treated as a single unit, e.g. Hydrological Simulation Program-Fortran (HSPF). These models describe mathematically the relation between rainfall and surface runoff without describing the physical process by which they are related. e.g. Unit Hydrograph approach. Spatial heterogeneity in *distributed models* is represented with a resolution typically defined by the modeler.

4. Based on type of Storm Event

Watershed-scale models can be further subdivided into *event-based* or *continuous-process models*. *Event-based models* simulate individual precipitation-runoff events with a focus on infiltration and surface runoff, while *continuous process models* explicitly account for all runoff components while considering soil moisture redistribution between the storm events.



Lesson 32 Case Study-Watershed Modelling for Soil and Water Conservation and Water Quality

Watershed models have become an important tool in addressing a wide spectrum of environmental and water resources problems, including water resources planning, development, design, operation and management. Floods, droughts; upland erosion; stream bank erosion; coastal erosion; sedimentation; nonpoint source pollution; water pollution from industrial, domestic, agricultural, and energy industry sources; migration of microbes; salinity and alkalinity of soils; deterioration of lakes; acid precipitation; disappearance of beaches; desertification of land; degradation of land; decay of rivers; irrigation of agricultural lands; proper management of water resources; conjunctive use of surface and groundwater; reliable design of hydraulic structures and the need for river training works are some of the critical environmental problems which are solved using watershed models.

32.1 Applications of Watershed Modelling

Watershed models help understand dynamic interactions between land surface hydrology and climate. For example, vegetation, snow cover and the permafrost active layer are some of the features which are quite sensitive to the lower boundary of the atmospheric system. The water and heat transfer between the land surface and atmosphere significantly influence hydrologic characteristics and yield, in turn, lower the boundary conditions for climate modelling.

Assessment of the impact of climate change on national water resources and agricultural productivity is made possible by the use of watershed models. Water allocation requires integration of watershed models with models of physical habitat, biological populations and economic response. Estimating the value of in-stream water use allows recreational, ecological and biological concerns to compete with traditional consumptive uses, such as agriculture, hydropower, municipality and industry. Watershed models are utilized to quantify the impacts of watershed management strategies linking human activities within the watershed to water quantity and quality of the receiving stream or lake for environmental and water resources protection.

32.2 Setting up a Watershed Model- Steps and Requirements

The modelling or model application, process can be described as comprised of three phases as shown in Fig. 32.1. Phase I includes data collection, model input preparation and parameter evaluation, i.e. all the steps needed to set up a model, characterize the watershed and prepare for model executions. Phase II is the model testing phase which involves calibration, validation and if possible a post-audit evaluation. This is the phase in which the model is evaluated to assess whether it can reasonably represent the watershed behaviour for the purposes of the study. Phase III includes the ultimate use of the model as a decision support tool for management and regulatory purposes.

Although specific application procedures for all watershed models differ due to the variations of the specific physical, chemical and biological systems each of them attempts to represent, they have many steps in common. The calibration and validation phase is especially critical since the outcome establishes how well the model represents the

watershed for the purpose of the study. Thus, this is the 'bottom-line' of the model application effort as it determines if the model results can be relied upon and used effectively for decision-making.

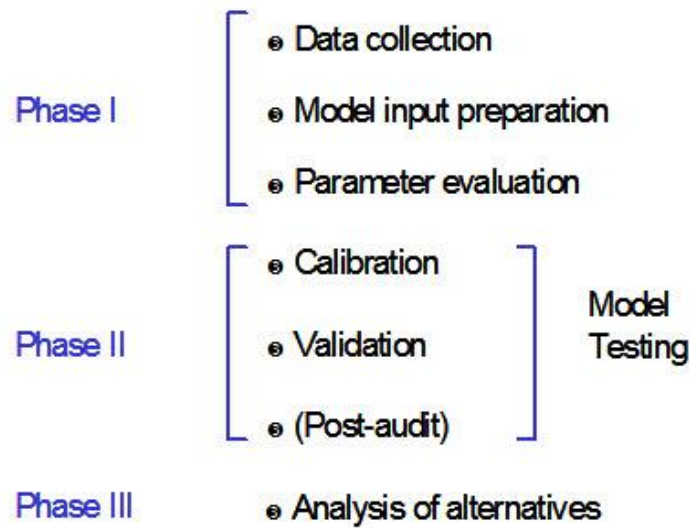

Fig. 32.1. Modelling Process. (Source: Singh and Frevert, 2002)

The data requirement for watershed modeling can be listed as:

1. Hydro-meteorologic, geo-morphologic, geologic, hydraulic and hydrologic (rainfall, snow, temperature, solar radiation, relative humidity, wind velocity and evapotranspiration)
2. Vegetation type, land use
3. Soil type, texture, infiltration, conductivity
4. Aquifer formation, rock type
5. Topography, slopes, length, area, perimeter (geo-morphometric)
6. Roughness, flow level, channel cross sections (hydraulic)
7. Flow depth, discharge, base flow, sub-surface flow (hydrologic)

32.3 Case Study

Watershed Modelling

A case study on water quantity, sediment yield and water quality is presented to analyse the scope of the hydrological model in particular SWAT (Soil Water and Assessment Tool) model. The model is a physically based, continuous time model, and simulates surface runoff, evapotranspiration, infiltration, percolation losses, channel transmission losses, channel routing, lateral flow as well as shallow and deep aquifer flow. It allows the partitioning of a watershed into a number of sub-watersheds and the input information for each sub-watershed is needed for modelling.

Study Area

The study was performed on Banha watershed with an area of 1,695 ha, located in the Upper Damodar Valley (UDV) in the Hazaribagh Command, District Chatra in Jharkhand, India (Fig. 32.2). The average annual rainfall in the area is 1200 mm of which more than 80% occurs during monsoon months from June to October and the rest in winter months (December and January). Daily temperature ranges from a maximum of 42.5°C (1st May, 1999) to a minimum of 2.5°C (18th January, 1999). Soils in the watershed are more or less uniform up to a depth of 0.5 m and vary texturally from loamy sand to loam with sandy loam as the common texture.

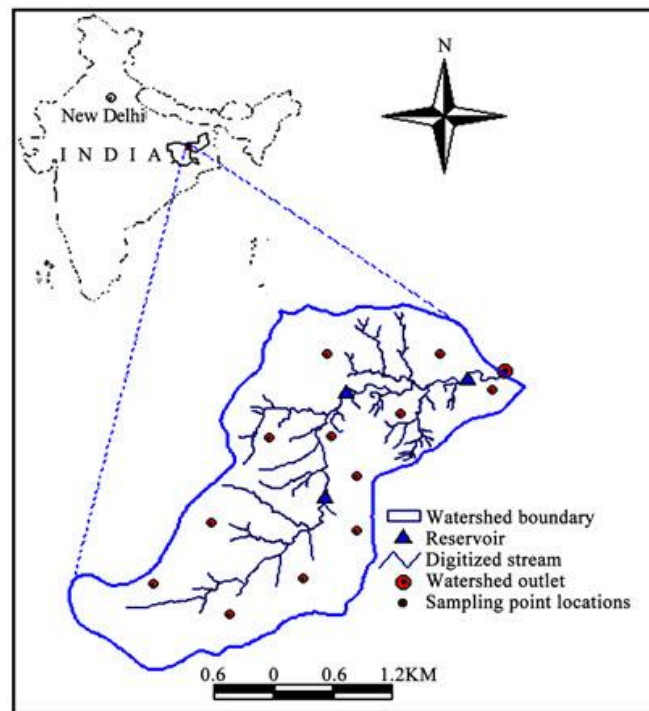

Fig. 32.2. Banha Watershed of DVC Command, Hazaribagh, Jharkhand, India.

The land use/land cover of the area during rainy season mainly comprises rice crop, although black gram, maize, soybean and vegetables are also grown on some upland patches. The watershed has a mixed forest comprising sal (*Shorea robusta*), mahua (*Madhuca indica*), kend (*Diospyros melanoxylon*) and palas (*Butea frondosa*) trees in an area of about 878 ha (Fig. 32.3). In the area there is no source of factory effluent or point sources of water pollution. There is only rural effluent from individual houses. Chemical fertilizers and farm yard manures (FYM) are generally used in crop cultivation practices. Therefore, the sources of possible water quality/pollution (Non-Point Source) in the area are fertilizers, individual housing effluent and forest residues.

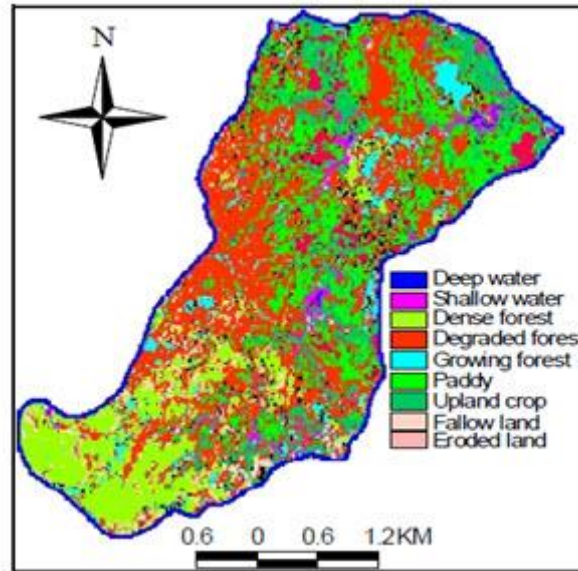

Fig. 32.3. Land Use/Land Cover Map of Banha Watershed for the Year 2000.

SWAT Model Description

In SWAT model, the *surface runoff* volume is estimated as shown below from daily rainfall by using the SCS curve number technique in which runoff is strongly influenced by the land cover/land use, soil type, slope and initial soil water content. The method reflects the effect of these factors on runoff generation from different areas of the watershed.

$$Q = \frac{(R - 0.2s)^2}{(R + 0.8s)} \quad R > 0.2s \quad (32.1)$$

$$Q = 0 \quad R \leq 0.2s \quad (32.2)$$

where, Q is the daily surface runoff (mm), R is the daily rainfall (mm) and s is a retention parameter (mm) which is related to the Curve Number (CN) and given as:

$$s = 254 \left(\frac{100}{CN} - 1 \right) \quad (32.3)$$

The sediment yield from each sub-basin of the watershed is computed by using the Modified Universal Soil Loss Equation (MUSLE). MUSLE uses the amount of runoff to simulate erosion and sediment yield.

$$Y = 11.8 (V.q_p)^{0.56} . K.C.PE.LS \quad (32.4)$$

where Y is the sediment yield from the sub-basin at time t , V is the surface runoff volume for sub-basin in m^3 , q_p is the peak flow rate for sub-basin in m^3/s , K is the soil erodibility factor, C is the crop management factor, PE is the erosion control practice factor and LS is the slope length and steepness factor. MUSLE uses the amount of runoff to simulate erosion and sediment yield.

For *water quality* assessment, SWAT uses the modified Erosion Productivity Impact Calculator (EPIC) model to compute nutrient yield and cycling from the sub-watersheds. In the present example (SWAT model application), the estimation of Nitrate-N and Phosphorous movement from the sub-watersheds along with the surface and sub-surface water is discussed briefly as given below.

Nitrate

The amount of NO_3-N contained in runoff, lateral flow and percolation are estimated as the product of the volume of water and concentration. The amount of NO_3-N in runoff is estimated for each sub-watershed by considering the top 10 mm soil layer only and is given as

$$V_{NO_3} = (QT)(C_{NO_3}) \quad (32.5)$$

Where V_{NO_3} is the amount NO_3-N lost from the first layer, QT is the total water lost from the first layer in mm, and C_{NO_3} is the concentration of NO_3-N in the first layer. Leaching and lateral subsurface flows in lower layers are estimated with the same approach used in the upper layer, except that surface runoff is not considered. The loading function estimates the daily organic N runoff loss based on the concentration of organic N in the top soil layer, the sediment yield and enrichment ratio as

$$YNO = 0.001(Y)(CON)(ER) \quad (32.6)$$

Where YNO is the organic N runoff loss at the outlet (kg/ha), CON is the concentration of organic N in the top soil layer (g/t), Y is the sediment yield (t/ha), and ER is the enrichment ratio and given as

$$ER = X_1 C_a^{X_2} \quad (32.7)$$

Where C_a is the sediment concentration (g/m^3), and X_1 and X_2 are parameters set by the upper and lower limits. When the enrichment ratio approaches 1.0, the sediment concentration would be extremely high and will decrease with the reduction of ER .

Phosphorous

P is mostly associated with sediment and soluble P runoff in SWAT is expressed as

$$YSP = \frac{0.01(C_{LPP})(Q)}{k_d} \quad (32.8)$$

Where YSP is the soluble P (kg/ha) lost in runoff volume Q (mm), C_{LPP} is the concentration of soluble P in the soil layer (g/t), and k_d is the P concentration in the sediment divided by that of the water (m^3/t). C_{LPP} is constant for the whole simulation and initially input to the model. The sediment-associated P is simulated with a loading function as

$$YP = 0.01(Y)(C_p)(ER) \quad (32.9)$$

Where YP is the sediment associated P loss in runoff (kg/ha), C_p is the concentration of P in the top soil layer (g/t) and ER is the enrichment ratio.

The model performs simultaneous computation on each sub-watershed and routes water, sediment and nutrients through reaches and finally sums as loadings from the watershed.

Model Calibration

Calibration of the SWAT model was done using the measured data for the monsoon months of June to September of 2000. The time series of measured and model simulated daily stream flow and sediment yield from the watershed were compared, as shown in Figures 32.4 and 32.5 respectively.

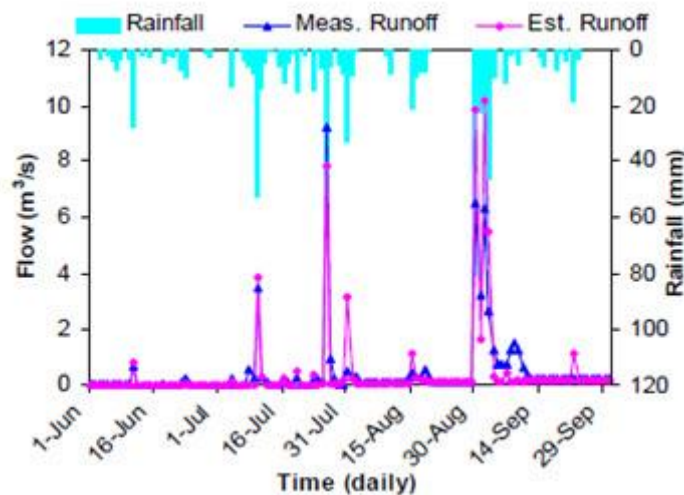

Fig. 32.4. Measured and SWAT Simulated Daily Flow.

The magnitude and temporal variation of simulated runoff showed a good response to rainfall distribution and a close match with the measured values, except that a few peaks marginally deviated from the measured daily runoff peaks. The differences between the measured and simulated runoff values can be ascribed to topographic and morphological heterogeneity of the watershed affecting the watershed runoff response.

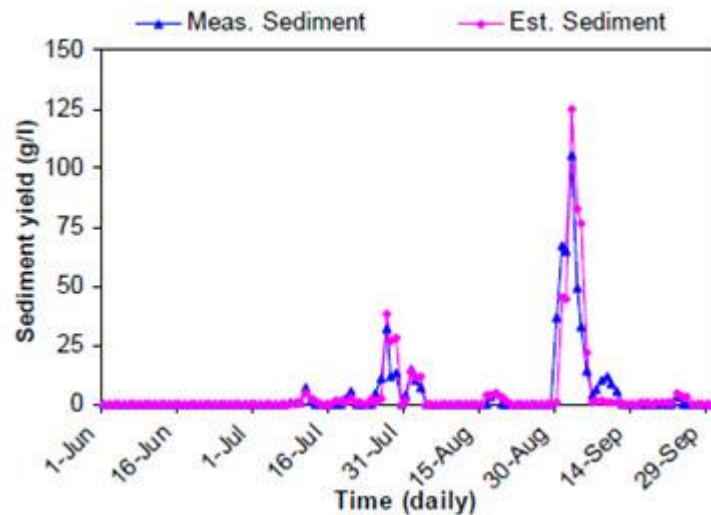

Fig. 32.5. Measured and SWAT Simulated Daily Sediment Yield.

The model simulated daily sediment yields were a little higher than the measured values for high rainfall events but for medium rainfall events the simulated values deviated less from the measured sediment yield. This can be attributed to the model rather than the rainfall characteristics. The differences can also be ascribed to the nature of rains and soil conditions over the watershed.

Simulation for Runoff and Sediment Yield

Using the measured rainfall and runoff data, the runoff response of the watershed was analyzed for the years 2000 and 2001 (Fig. 32.6). From the figure a close match between the rainfall and runoff is obtained which can be attributed to the small size of the watershed. For daily rainfall of less than 10 mm generated runoff is negligible particularly in the initial period of monsoon when the soil is relatively dry. Similarly for rainfall events at the end of monsoon, generated runoff was small due to less intense and intermittent rainfall events. Mid monsoon season runoff in July and August is distinctly higher for medium to high rainfall events due to sufficient soil wetness. In 2000 and 2001, the average daily rainfall was 6.0 and 5.0 mm with a standard deviation of 13.4 and 13.7 mm and the generated average daily runoff was 2.4 and 2.3 mm with a standard deviation of 6.3 and 3.7 mm, respectively. Monthly rainfall-runoff observations showed that proportion of runoff to rainfall was less initially but increased gradually towards the end of monsoon season. The trends of monthly runoff and rainfall were, however, exceptionally different in 2001 when the maximum values of rainfall and runoff occurred in the month of June and their magnitudes decreased successively in the remaining months (July–September) of the monsoon season.

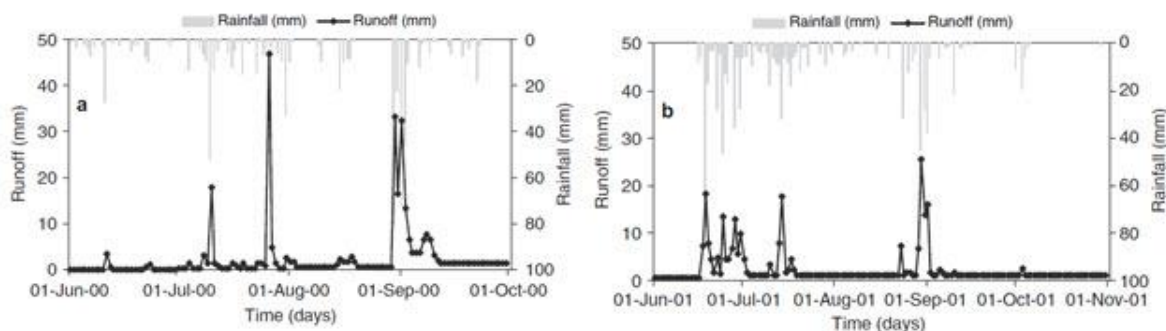

Fig. 32.6. Daily Rainfall/Runoff Distributions for the Years 2000 and 2001.

Regression analysis was performed to investigate the relationships among daily rainfall, runoff and sediment yield (Fig. 32.7 and 32.8). Slightly better correlation between rainfall and runoff with coefficients of determination of 0.83 and 0.76 in 2000 and 2001 respectively (Fig. 32.7) was found as against the respective values of 0.80 and 0.77 between rainfall and sediment yield (Fig. 32.8). It was also observed that a relatively uniform rainfall during the monsoon months in 2000 resulted in a better relationship compared to the year 2001 when rainfall was more non-uniformly distributed with time. Regression analyses revealed that daily rainfall had a higher influence on daily runoff and sediment yield, even though the watershed was multi-vegetated. The effect of land use and land cover (LULC) on sediment yield from different sub-watersheds was more conspicuous. Better forest cover and hence better protection of soil from the erosive effect of rains and overland flow resulted in smaller sediment yield. Higher infiltration of water in sub-watersheds with more area under forest cover prevented overland flow in rills and gullies and resulted in much less soil erosion rates. On the contrary, infiltration rate was lower in cultivated land and as a result runoff and sediment yield were higher.

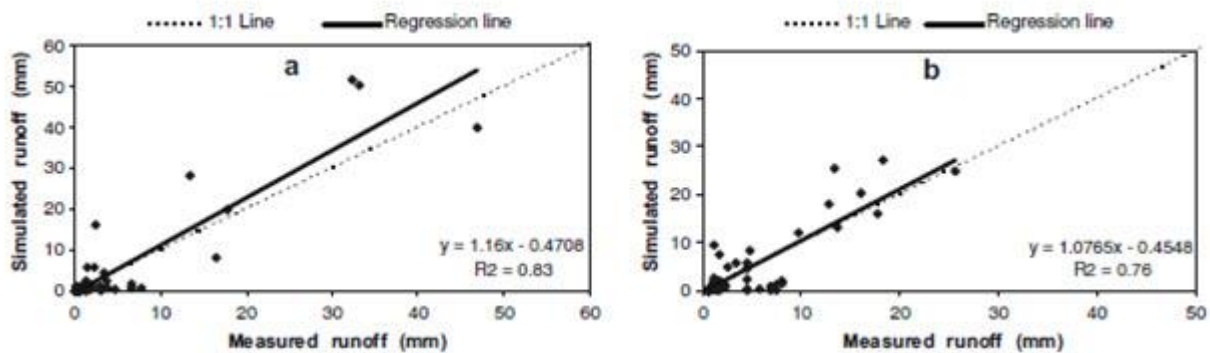

Fig. 32.7. Comparison between the Measured and SWAT Simulated Daily Runoff During June–September, 2000 (a) and June–October, 2001 (b).

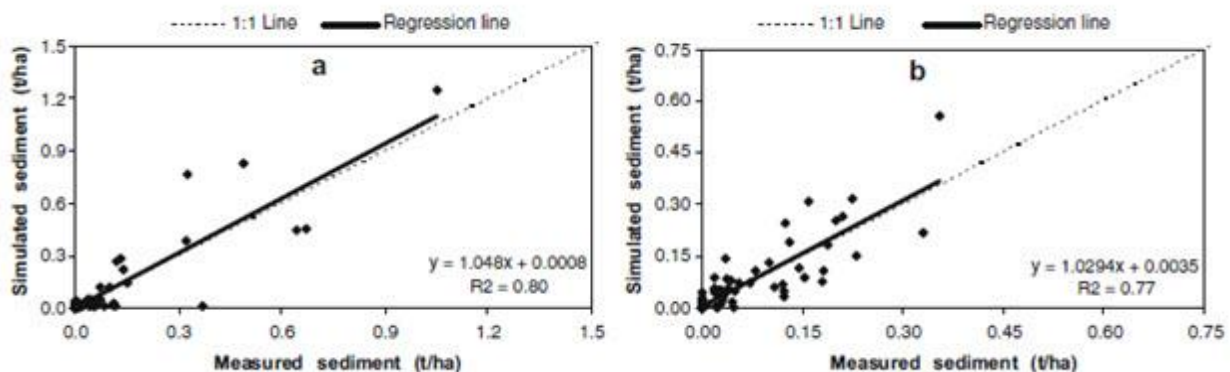

Fig. 32.8. Comparison between the Measured and SWAT Simulated Daily Sediment Yield During June–September, 2000 (a) and June–October, 2001 (b). (Source: Mishra et al., 2007)

Simulation for NPS Pollution

The calibrated SWAT model was used to simulate the water pollutants commonly known as Non-Point Source (NPS) pollution due to losses of nutrients from the watershed during June to September, 2000 and simulate the same during monsoon months of June to October of 2001. Measured concentrations of $\text{NO}_3\text{-N}$, $\text{NH}_4\text{-N}$ and soluble P in the surface runoff at the watershed outlet in 2000 and 2001 were used for the validation of model simulations.

Measured and simulated $\text{NO}_3\text{-N}$, $\text{NH}_4\text{-N}$ and soluble P concentrations at the watershed outlet for both the seasons are presented in Fig. 32.9, 32.10 and 32.11 respectively.

From Fig. 32.9 it is seen that NPS $\text{NO}_3\text{-N}$ loading for the year 2000 is generally closely predicted for all the events, with high statistical agreement, except for the initial events. Nash-Sutcliffe Efficiency coefficients values (0.95 and 0.99) and coefficient of determination values (0.99 and 0.99) indicate a high agreement for both the years.

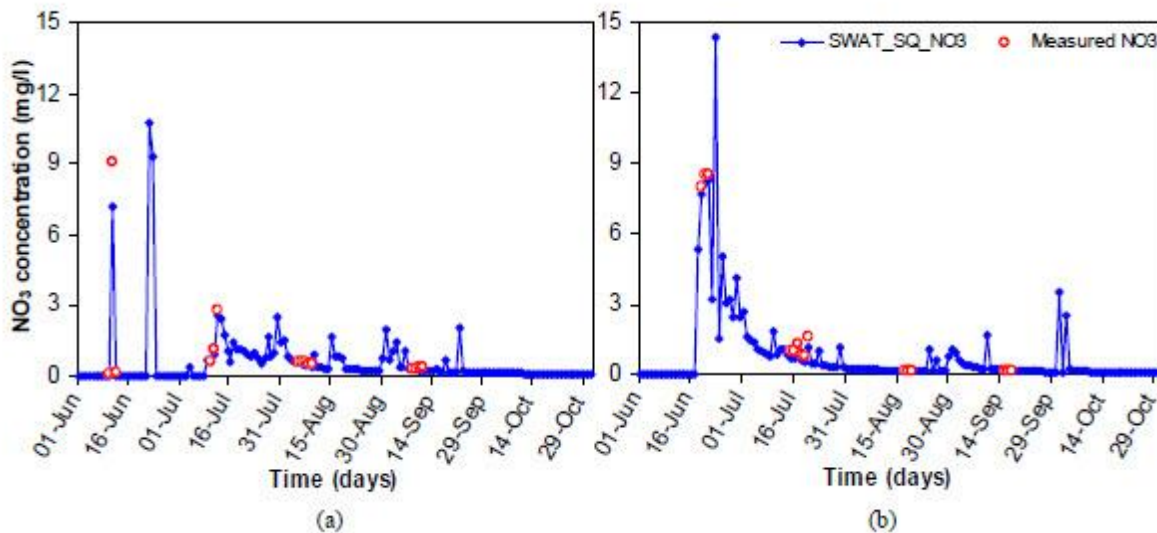

Fig. 32.9. Measured and SWAT Simulated NPS $\text{NO}_3\text{-N}$ concentration at the Watershed Outlet in 2000 (a) and in 2001 (b). (Source: Mishra et al., 2009)

Comparison of the measured and simulated concentrations of $\text{NH}_4\text{-N}$ for 2000 and 2001 shown in Fig. 32.10 a & b respectively reveal that the simulated values of $\text{NH}_4\text{-N}$ are in close agreement with the measured values as indicated by the values of coefficients of determination (0.99 and 0.90) and Nash-Sutcliffe Efficiency coefficients (0.98 and 0.88). Statistical tests reveal that model predictions of $\text{NH}_4\text{-N}$ are acceptable and may be used for the analysis of watershed behaviour.

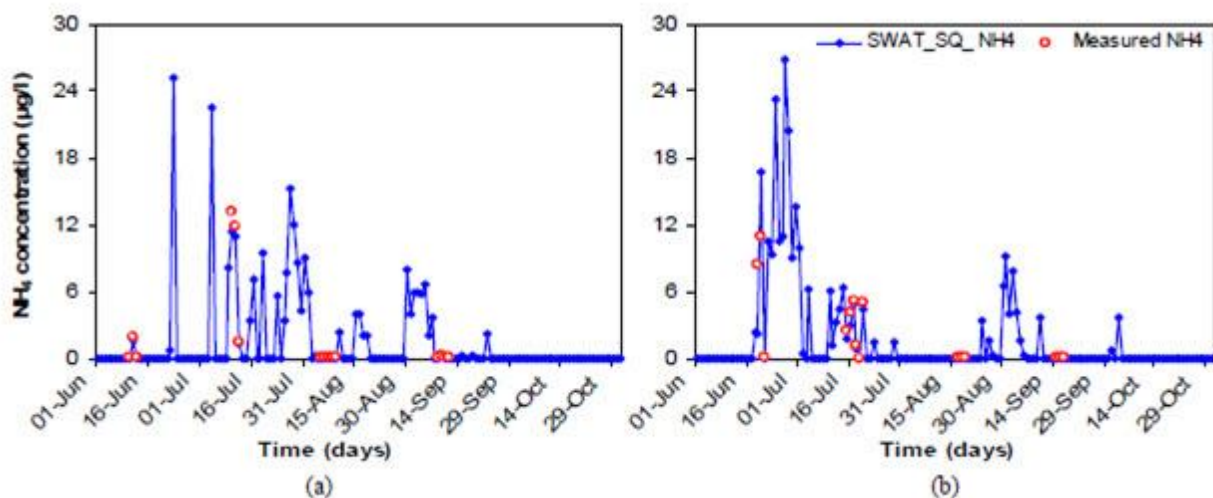

Fig. 32.10. Measured and SWAT Simulated NPS- $\text{NH}_4\text{-N}$ concentration at the Watershed Outlet in 2000 (a) and in 2001 (b). (Source: Mishra et al., 2009)

Comparison between the measured and simulated values of soluble P for the selected observation dates of 2000 and 2001 (Fig. 32.11 a & b) reveal that the simulated values of soluble P are marginally under-predicted by the model. The values of coefficient of determination (0.98 for 2000 and 0.90 for 2001) and Nash-Sutcliffe simulation efficiencies (0.89 for 2000 and 0.83 for 2001) indicate a better agreement between the measured and simulated values for 2000. Overall statistical comparison shows that the model performance was satisfactory with respect to the simulation of soluble P.

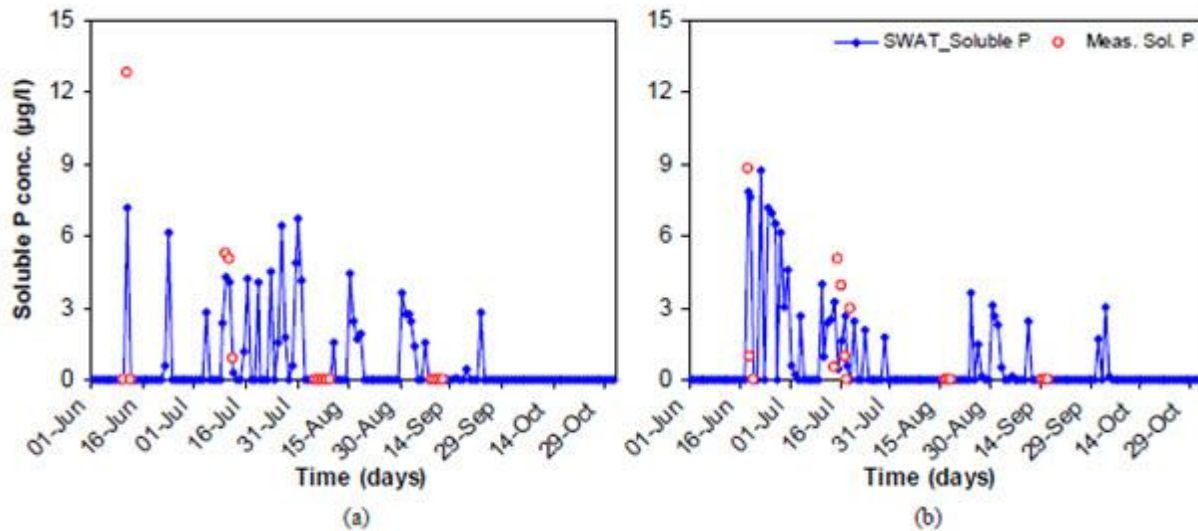

Fig. 32.11. Measured and SWAT Simulated NPS Water Soluble P concentration at the Watershed Outlet in 2000 (a) and in 2001 (b).

(Source: Mishra et al., 2009)

Monthly surface and sub-surface losses of $\text{NO}_3\text{-N}$, $\text{NH}_4\text{-N}$, soluble P, organic N and organic P per unit area as NPS pollutants loads from the watershed to the downstream water were estimated from the validated SWAT model. The results obtained are shown in Figure 32.12. It is apparent that an appreciable amount of $\text{NO}_3\text{-N}$ was lost in surface runoff with the percolated water. However, nutrient losses due to the sub-surface flow were relatively low. The loss of organic N was also quite high compared to organic P and $\text{NH}_4\text{-N}$. The quantified nutrient loads from the watershed varied from 2.57 to 4.52 kg/ha as $\text{NO}_3\text{-N}$ lost in surface runoff, 0.17 to 0.29 kg/ha as $\text{NO}_3\text{-N}$ lost in sub-surface runoff, 1.73 to 3.87 kg/ha as $\text{NO}_3\text{-N}$ lost with percolated water, 0.13 to 0.14 kg/ha as organic-N, 0.02 kg/ha as $\text{NH}_4\text{-N}$, 0.02 kg/ha as organic P and 0.01 kg/ha as soluble P from the watershed as NPS pollutants during the monsoon months of 2000 and 2001. A clear variation in simulated losses of N and P for 2000 and 2001 is seen which is due to the variation in rainfall intensity and distribution in these two years and had a high effect on transport characteristics of NPS pollutants.

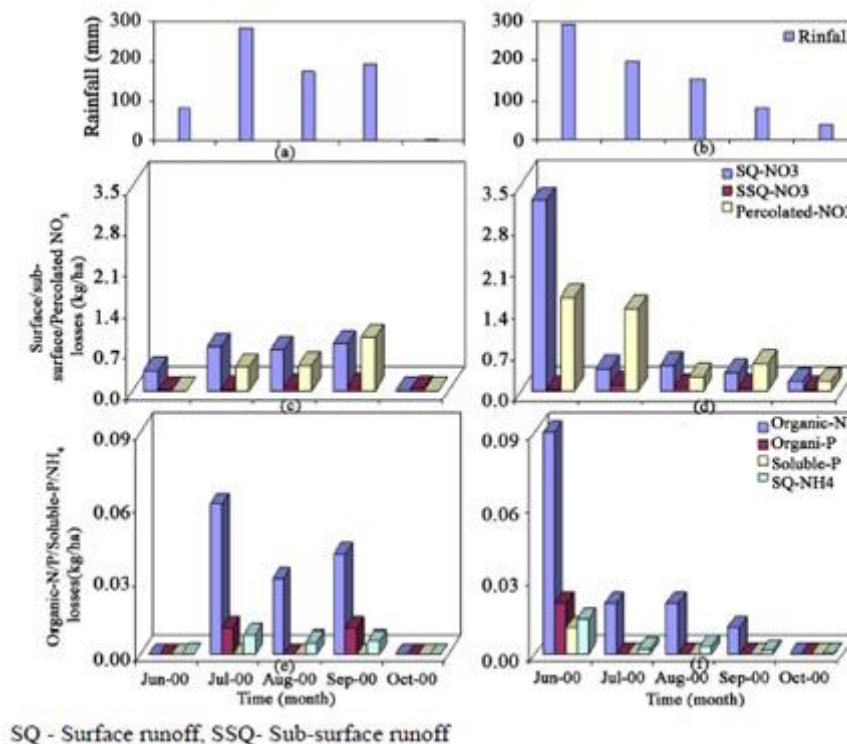

Fig. 32.12. SWAT Simulated Surface and Sub-surface Losses of $\text{NO}_3\text{-N}$, $\text{NH}_4\text{-N}$, Soluble P, Organic N and Organic P from the Watershed in 2000 and 2001. (Source: Mishra et al., 2009)

32.4 Hydrological Modelling for Future Water Quantity Assessment

Climate variability and change are expected to alter regional hydrologic conditions and result in variety of impacts on water resource systems throughout the world. Potential impacts may include changes in hydrological processes such as evapotranspiration, soil moisture, water temperature, stream flow volume, timing and magnitude of runoff and frequency and severity of floods, all of which would cause changes in other environmental variables affecting plant growth. Understanding the possible impacts of climate change on streamflow is of great importance for the appropriate design and management of water resources in any region. The effect of climate change on future water balance components at different sub-basins of the Krishna river basin is evaluated as an example. In order to accomplish this objective, SWAT (Soil and Water Assessment Tool), a distributed hydrologic model has been used. The future projected precipitation and temperature changes projected by PRECIS regional climate model under A1B emissions scenario were input into SWAT to predict the future streamflow changes. The results obtained from this example are expected to provide more insight into the availability of future streamflow and to provide local water management authorities with a planning tool.

Study Area: The Krishna river is the chosen area for this example. The Krishna River Basin (258,948 km²) located in semi-arid southern India is the fourth largest in India in terms of annual discharge, and fifth in terms of surface area. The drainage area of the entire basin is about 2,58,948 km² of which 26.8% lies in Maharashtra, 43.8% in Karnataka and 29.4 % in Andhra Pradesh and its tributaries form an important integrated drainage system in the central portion of the Indian Peninsula. A major part of the water available in the Krishna basin originates from the humid regions of the Western Ghat mountains where precipitation exceeds 5000 mm. The river terminates at the Krishna delta in the Bay of Bengal.

Data inputs for Hydrological Modeling: The SWAT model requires data on terrain, land use, soil weather for the assessment of water-resources availability at desired locations of the drainage basin. To create a SWAT dataset, the interface needs to access ARC GIS with spatial analyst extension and data set files, which provide certain types of information about the watershed.

Spatial Data:

1. Digital Elevation Model (DEM)
2. Soil Data Layer
3. Land Use/ Land Cover layer

Climatic Data: The model requires climatic data on

1. Precipitation
2. Maximum and minimum temperatures
3. Solar radiation
4. Wind speed
5. Relative humidity

For weather generator data set, observed climatology of the basin has been used.

Weather Data (Climate Model Data): The data generated in transient experiments PRECIS at a resolution $0.44^\circ \times 0.44^\circ$ latitude by longitude RCM grid points was used for this study. The daily weather data on temperature (maximum and minimum), rainfall, solar radiation, wind speed and relative humidity at all the grid locations were processed. The centroid of each grid point was then taken as the location of weather station to be used in the SWAT model. This model has been used for processing the control/present (representing series (1960-1990) and the GHG (Green House Gas) A1B scenarios, (representing series 2011-2040 and 2041-2070).

Hydrological Modeling of the Basin: The Arc SWAT distributed hydrologic model has been used in this example. The basin has been sub-divided into 23 sub-basins using the threshold value to divide the basin into a reasonable number of sub-basins so as to account for the spatial variability. After mapping the basin for terrain, land use and soil, simulated weather conditions predicted for control and GHG climate are incorporated into the model. The Krishna basin has been simulated using ARCSWAT model using generated daily weather data by PRECIS control climate scenario (1960-1990). In this evaluation, the model has been used with the assumption that the river basin is a virgin area without any manmade changes. The model satisfactorily generates the detailed outputs on flow at sub-basin outflow points, actual evapotranspiration and soil moisture status at monthly intervals.

Changes in Water Balance Components: As mentioned above the monthly average precipitation, actual evapotranspiration, potential evapotranspiration, surface flow and water yield as simulated over the Krishna basin as a whole for control and two scenarios (A1B PRECIS, 2011 - 2040 and 2041 - 2070) have been obtained. The variation in mean monthly water balance components from control to GHG scenario, both in terms of change

in individual values of these components as well as percentage of change over control is shown in Fig. 32.13.

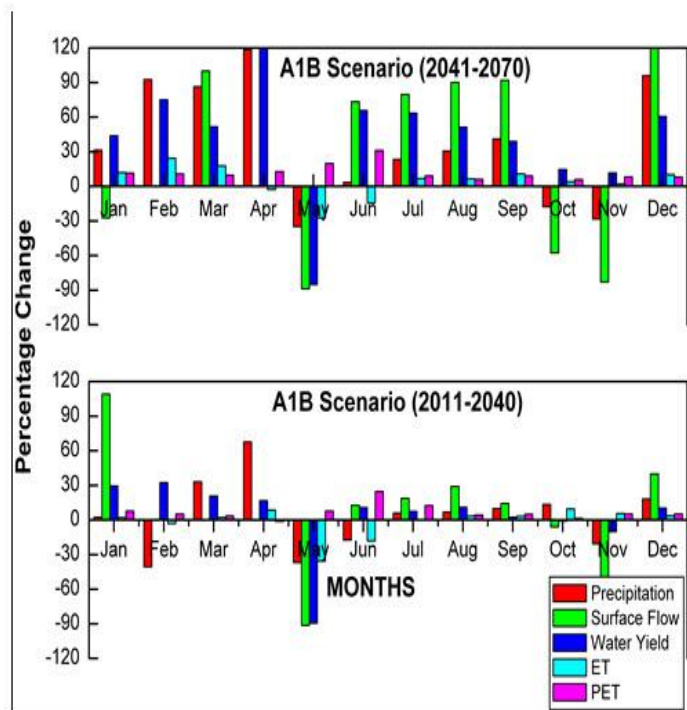

Fig. 32.13. Difference in Mean Monthly Water Balance Components from Control to GHG Scenario. (Source: Kulkanri and Bansod, 2012)

It may be observed from the above figures that increase in precipitation has been predicted in almost more than half of the months of the year, while decrease in precipitation for the remaining months has been predicted. The magnitude of this increase/decrease in precipitation over the Krishna basin has been variable over various months. The monthly average precipitation, actual evapotranspiration and water yield as simulated by the model over the basin will be increased during the period from 2041 to 2070.

Limitations of the Method: It also should be noted that future flow conditions cannot be projected exactly due to uncertainty in climate change scenarios and GCM outputs. However, the general results of this analysis should be considered and incorporated into water resources management plans in order to promote more sustainable water use in the study area. In the assessment of impact of climate change on water availability, two models based on simplified assumptions were considered in the analyses and outputs. Hence, it is quite likely that the uncertainties presented in each of the models and the model outputs keep on accumulating while progressing towards the final output. These uncertainties include uncertainty linked to data quality, general circulation model (GCMs) and emission scenarios. The model simulations considered only future climate change scenarios assuming all other things as constants. But change in land use scenarios, soil, management activities and other climate variables will also contribute to some extent on water availability and crop production.

Conclusions: In this study projections of precipitation and evaporation change and their impacts on stream flow were investigated in the Krishna river basin for the 21st century. The SWAT model is able to simulate the hydrology of the Krishna river basin successfully. The future annual discharge, surface runoff and baseflow in the basin show increases over the present as a result of future climate change. It should also be noted that future flow

conditions cannot be projected exactly due to uncertainty in climate change scenarios and GCM outputs. However, the general results of this analysis should be identified and incorporated into water resources management plans in order to promote more sustainable water use in the study area. The major limitation of this study is that the model simulations considered only future climate change scenarios assuming all other things as constants. But change in land use scenarios, soil, management activities and other climate variables will also contribute greatly on water availability and crop production.



***** 😊 *****

This Book Download From e-course of ICAR
**Visit for Other Agriculture books, News,
Recruitment, Information, and Events at**
WWW.AGRIMOON.COM

Give FeedBack & Suggestion at info@agrmoon.com

Send a Massage for daily Update of Agriculture on WhatsApp
+91-7900 900 676

DISCLAIMER:

The information on this website does not warrant or assume any legal liability or responsibility for the accuracy, completeness or usefulness of the courseware contents.

The contents are provided free for noncommercial purpose such as teaching, training, research, extension and self learning.

***** 😊 *****

Connect With Us:

